

3. Tools and Equipment

The following section provides information about the tools and equipment that will be necessary to properly service the A/C system.



Since equipment may vary slightly depending on the manufacturer, it is important to always read and follow the manufacturer's instructions.

CAUTION:

When working on vehicles with the HFC-134a system, only use HFC-134a specified tools and parts. Do not mix with CFC-12 tools and parts. If HFC-134a and CFC-12 refrigerant or com-

pressor oil is mixed, poor lubrication will result and the compressor itself may be destroyed. In order to help prevent mixing HFC-134a and CFC-12 parts and liquid, the tool and screw type and the type of service valves used are different. The gas leak detectors for the HFC-134a and CFC-12 systems must also not be interchanged.

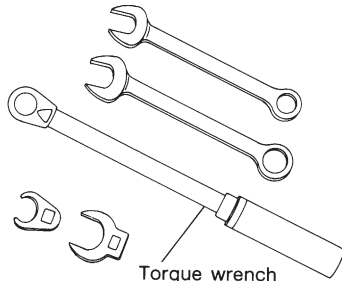
	HFC-134a	CFC-12
Tool & screw type	Millimeter size	Inch size
Valve type	Quick joint type	Screw-in type

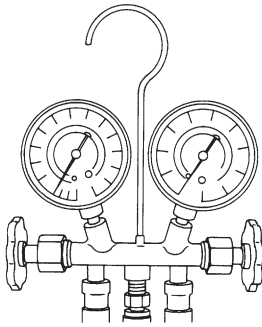
Tools and Equipment	Description
<ul style="list-style-type: none"> ● WRENCH Various WRENCHES will be required to service any A/C system. A 7 to 40 N·m (0.7 to 4.1 kg·m, 5 to 30 ft·lb) torque wrench with various crowfoot wrenches will be needed. Open end or flare nut wrenches will be needed for back-up on the tube and hose fittings. 	 <p style="text-align: center;">Torque wrench</p> <p style="text-align: right;">G4M0571</p>
<ul style="list-style-type: none"> ● APPLICATOR BOTTLE A small APPLICATOR BOTTLE is recommended to apply refrigerant oil to the various parts. They can be obtained at a hardware or drug store. 	 <p style="text-align: right;">G4M0572</p>
<ul style="list-style-type: none"> ● MANIFOLD GAUGE SET A MANIFOLD GAUGE SET (with hoses) can be obtained from either a commercial refrigeration supply house or from an auto shop equipment supplier. 	 <p style="text-align: right;">G4M0573</p>

4-7 [W300]

3. Tools and Equipment

SERVICE PROCEDURE

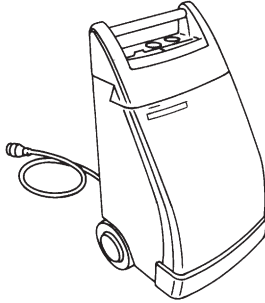
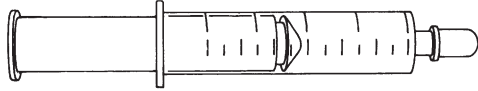
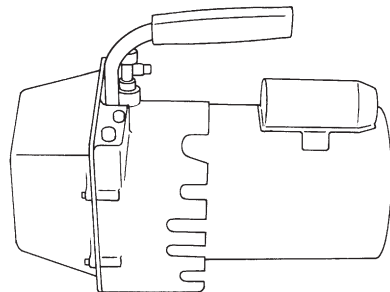
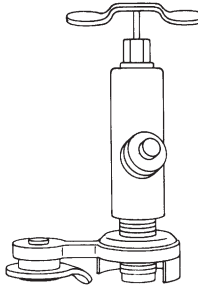
Tools and Equipment	Description
<ul style="list-style-type: none"> ● REFRIGERANT RECOVERY SYSTEM A REFRIGERANT RECOVERY SYSTEM is used for the recovery and reuse of A/C system refrigerant after contaminants and moisture have been removed from the refrigerant. 	 <p style="text-align: right;">G4M0574</p>
<ul style="list-style-type: none"> ● SYRINGE A graduated plastic SYRINGE will be needed to add oil back into the system. The syringe can be found at a pharmacy or drug store. 	 <p style="text-align: right;">G4M0575</p>
<ul style="list-style-type: none"> ● VACUUM PUMP A VACUUM PUMP (in good working condition) is necessary, and may be obtained from either a commercial refrigeration supply house or an automotive equipment supplier. 	 <p style="text-align: right;">G4M0576</p>
<ul style="list-style-type: none"> ● CAN TAP A CAN TAP for the 397 g (14 oz) can is available from an auto supply store. 	 <p style="text-align: right;">G4M0577</p>

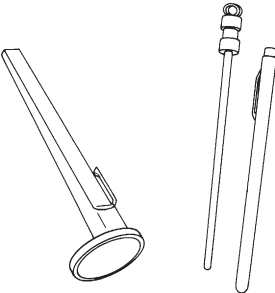
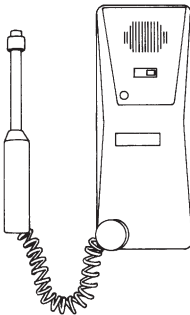
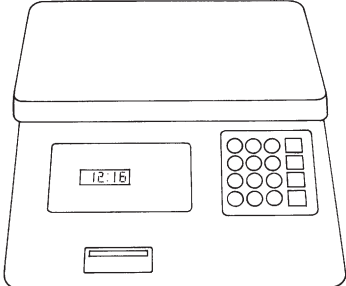
Tools and Equipment	Description
<ul style="list-style-type: none"> ● THERMOMETER Pocket THERMOMETERS are available from either industrial hardware store or commercial refrigeration supply houses. 	 <p style="text-align: right;">G4M0578</p>
<ul style="list-style-type: none"> ● ELECTRONIC LEAK DETECTOR An ELECTRONIC LEAK DETECTOR can be obtained from either a specially tool supply or an A/C equipment supplier. 	 <p style="text-align: right;">G4M0579</p>
<ul style="list-style-type: none"> ● WEIGHT SCALE A WEIGHT SCALE such as an electronic charging scale or a bathroom scale with digital display will be needed if a 13.6 kg (30 lb) refrigerant container is used. 	 <p style="text-align: right;">G4M0580</p>

4. O-ring Connections

A: GENERAL

The following points should be kept in mind when assembling O-ring connections.

- 1) Avoid unnecessary handling and contact of O-rings with your hands, since even clean fingers contain body acids, which can contaminate the O-ring surface.
- 2) Do not handle O-rings with gloves, shop towels, etc., since lint particles may cling to the O-ring, possibly causing a leak upon assembly.
- 3) Always lubricate O-rings before assembly to allow the O-ring to seat itself properly.
- 4) Be certain to use torque wrenches when tightening O-ring fittings, because overtightening can not only damage the O-ring, but it can distort the tube end as well.