

11. Compressor

A: INSPECTION

1. COMPRESSOR CLUTCH

NOTE:

- Compressor is a swash plate type. When trouble occurs, replace compressor as a single unit.
- Compressor clutch trouble is often caused by clutch slippage and noise. Check and take corrective measures, as required.

1) Remove belt cover.

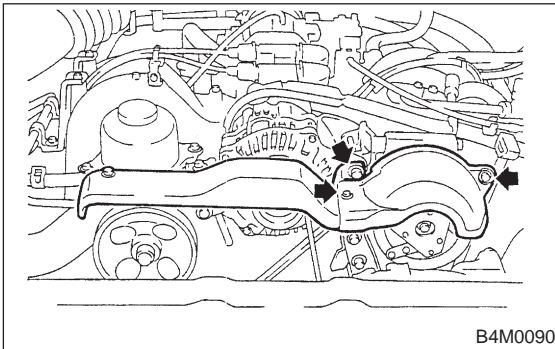

2) Compressor clutch trouble is often caused by clutch slippage and noise. Check and take corrective measures, as required.

Clearance:

0.3 — 0.6 mm (0.012 — 0.024 in)

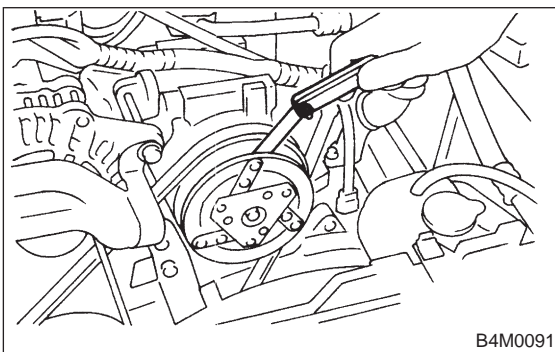

- 3) Check that voltage applied to magnetic coil is at least 10.5 volts.
- 4) When noise is noted, check that it originates in either compressor or pulley bearing.

B: REMOVAL

1) Disconnect ground cable from battery.

2) Discharge refrigerant using refrigerant recovery system. <Ref. to 4-7 [W600].>

- (1) Fully close low-pressure valve of manifold gauge.
- (2) Connect low-pressure charging hose of manifold gauge to low-pressure service valve.
- (3) Open low-pressure manifold gauge valve slightly, and slowly discharge refrigerant from system.

CAUTION:

Do not allow refrigerant to rush out. Otherwise, compressor oil will be discharged along with refrigerant.

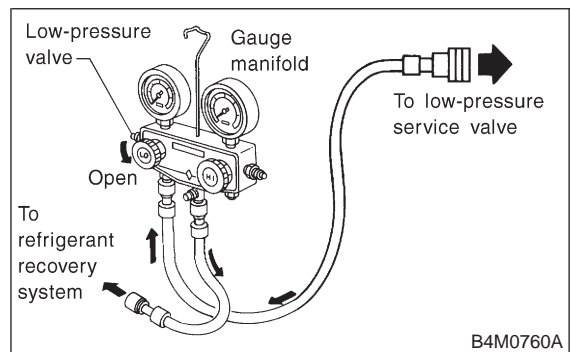

3) Remove low-pressure hose (a) and high-pressure hose (b).

CAUTION:

- Be careful not to lose O-ring of low-pressure hose.
- Plug the opening to prevent foreign matter from entering.

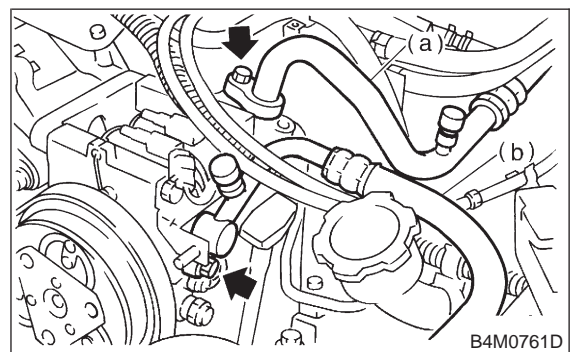

- 4) Remove compressor belt cover and alternator belt cover:
Remove bolts which secure belt covers.

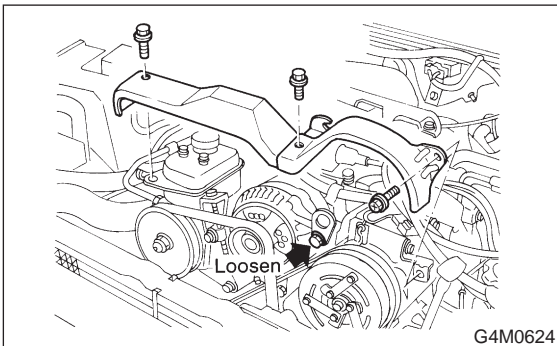

- 5) Remove alternator V-belt:
(1) Loosen lock bolt on alternator bracket.
(2) Turn adjusting bolt and remove V-belt.

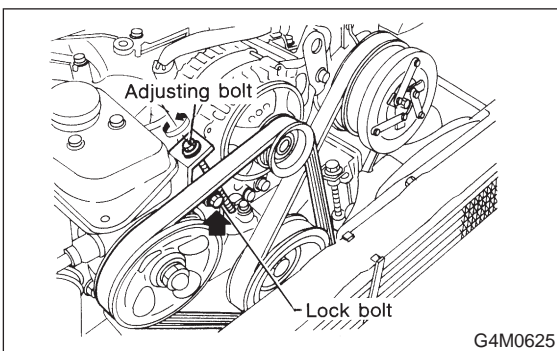

- 6) Remove compressor V-belt:
(1) Loosen lock nut on idler pulley.
(2) Turn adjusting bolt and remove V-belt.

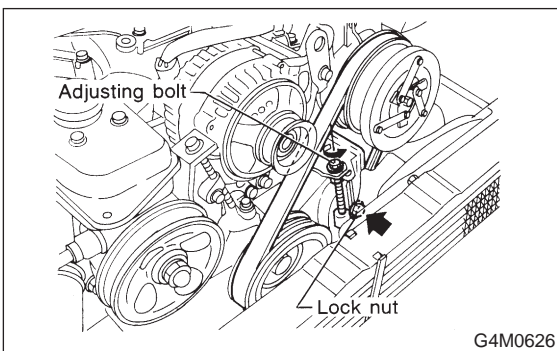

- 7) Disconnect alternator harness.

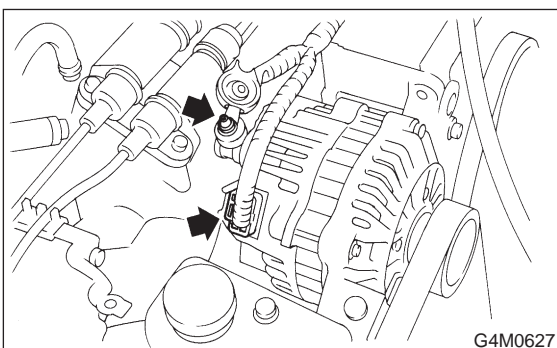

- 8) Disconnect compressor harness:
Disconnect compressor harness from body harness.
9) Lower bracket:
Remove bolts which secure lower compressor bracket.

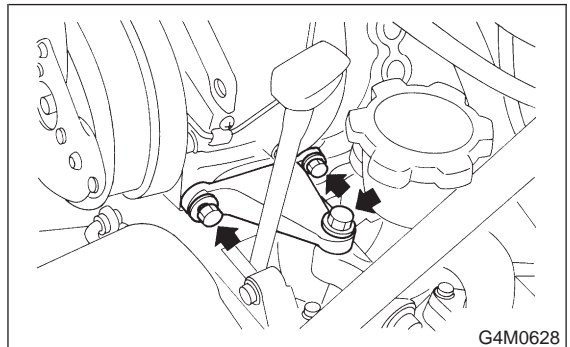

- 10) Remove compressor:
(1) Remove bolt which secure compressor.
(2) Remove compressor from bracket.

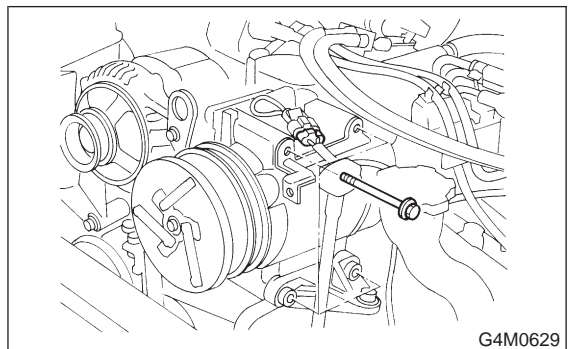

C: INSTALLATION

- 1) Install compressor:
Install compressor on bracket.

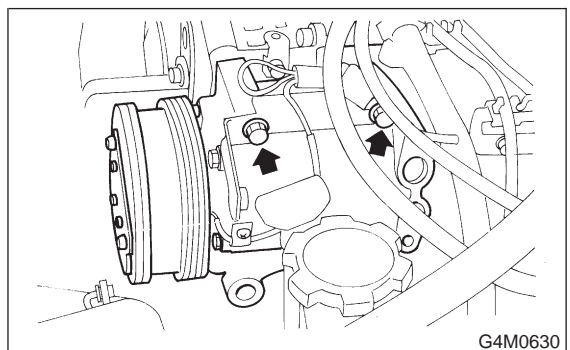

- 2) Connect compressor harness.
3) Connect alternator harness.
4) Install compressor V-belt (Rear):
After adjusting belt tension, tighten tension pulley lock nut securely.

4-7 [W11C0]

11. Compressor

SERVICE PROCEDURE

5) Install alternator V-belt:
After adjusting V-belt tension, tighten alternator bracket lock bolt securely.

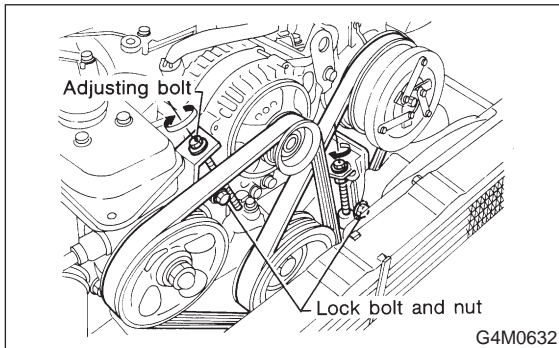

6) Check drive belt tension and adjust it if necessary by changing alternator position and/or idler pulley position.

CAUTION:

- Ensure that the V-belt is aligned correctly. If it is not, check for loose bolts.
- The V-belt should not be too tight or too loose.

A belt which is too tight may break bearing or cause gas to leak from the shaft seal. A belt which is too loose slips, thereby causing the belt cut.

- After completing the compressor installation and testing the system operation, check and adjust the tension of both V-belts again.

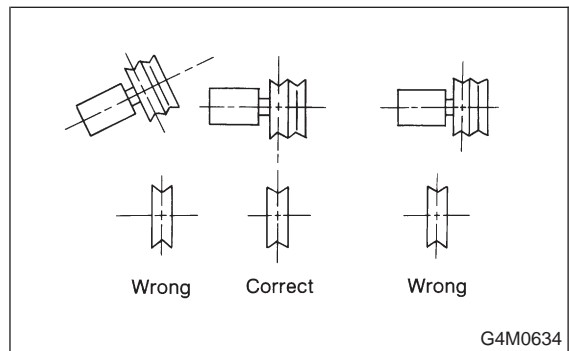

Pulley arrangement	Tension mm (in)/98N (10 kg, 22 lb)	
	(A)	(B)
<p>Figures in table refer to the number of grooves in pulleys. C/P: Crankshaft pulley ALT: Alternator pulley P/S: Power steering oil pump pulley A/C: Air conditioner compressor pulley I/P: Idler pulley</p>	<p>*New belt: 7.0 – 9.0 (0.276 – 0.354) Existing belt: 9.0 – 11.0 (0.354 – 0.433)</p>	<p>*New belt: 7.5 – 8.5 (0.295 – 0.335) Existing belt: 9.0 – 10.0 (0.354 – 0.394)</p>
<p>*When replacing belts with new ones, adjust tensions to specification and then readjust to the same specification after running engine for 5 minutes.</p>		

B4M1098A

7) Install high-pressure hose (b).
Connect high-pressure hose with compressor.

CAUTION:

Be sure to apply compressor oil to the periphery of O-ring.

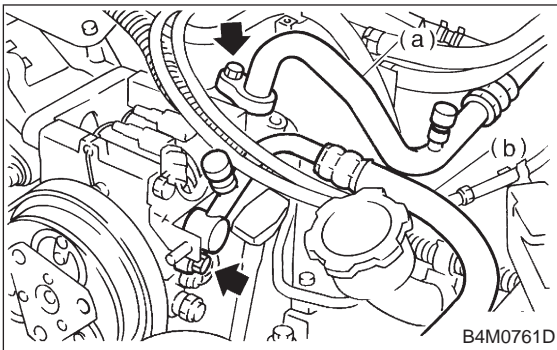

8) Install low-pressure hose (a).
Connect low-pressure hose with compressor.

CAUTION:

Be sure to apply compressor oil to the periphery of O-ring.

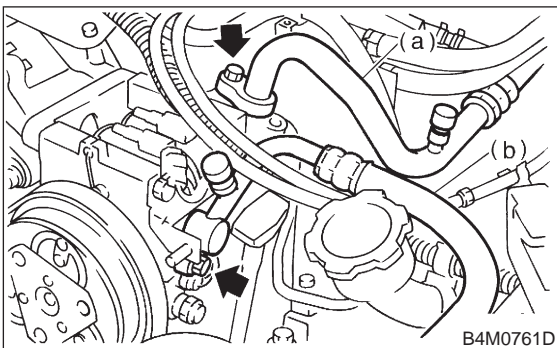

9) Install belt cover.

10) Connect ground cable to negative terminal of battery.

11) Charge refrigerant. <Ref. to 4-7 [W7H0].>

12. Condenser

A: REMOVAL AND INSTALLATION

- 1) Disconnect battery negative terminal.
- 2) Discharge refrigerant using refrigerant recovery system. <Ref. to 4-7 [W600].>
- 3) Remove front grille.

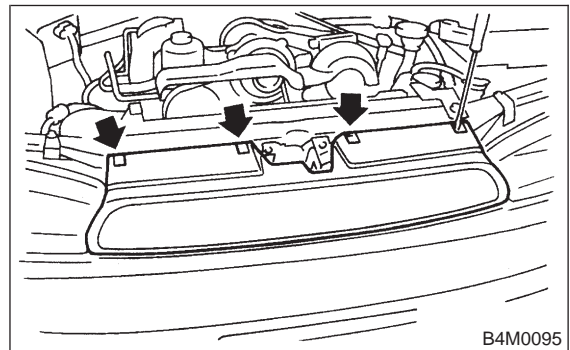

- 4) Remove canister from bracket.

CAUTION:

- Do not disconnect hose from canister.
- Insert air vent hose of canister into the hole on body.

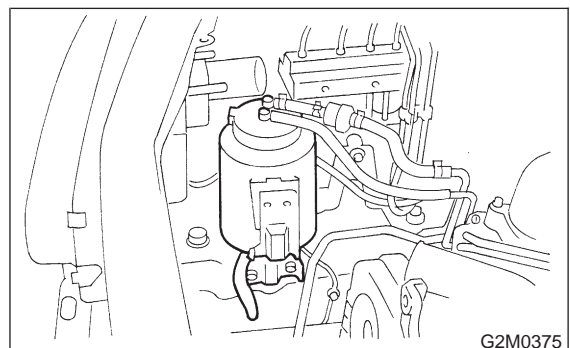

- 5) Remove the radiator upper bracket of both side.
- 6) Disconnect high-pressure hose (a) and high-pressure pipe (b) from condenser.

