

## 4. Master Cylinder

### A: LHD MODEL

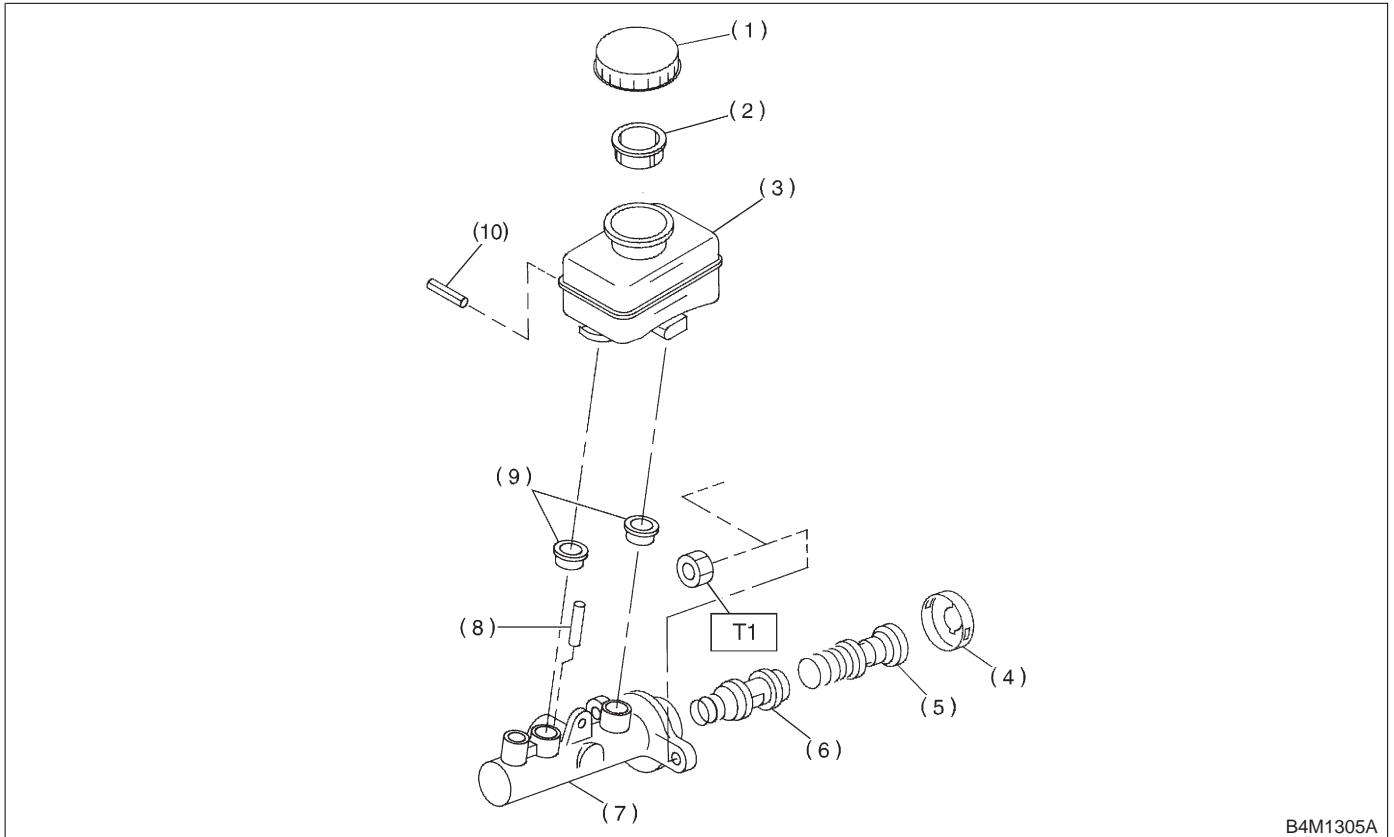

- |                     |                             |
|---------------------|-----------------------------|
| (1) Cap             | (6) Secondary piston        |
| (2) Filter          | (7) Cylinder body           |
| (3) Reservoir tank  | (8) Cylinder pin (With ABS) |
| (4) Piston retainer | (9) Seal                    |
| (5) Primary piston  | (10) Pin                    |

**Tightening torque: N·m (kg·m, ft·lb)**

**T1: 14±4 (1.4±0.4, 10.1±2.9)**

# COMPONENT PARTS

## B: RHD MODEL

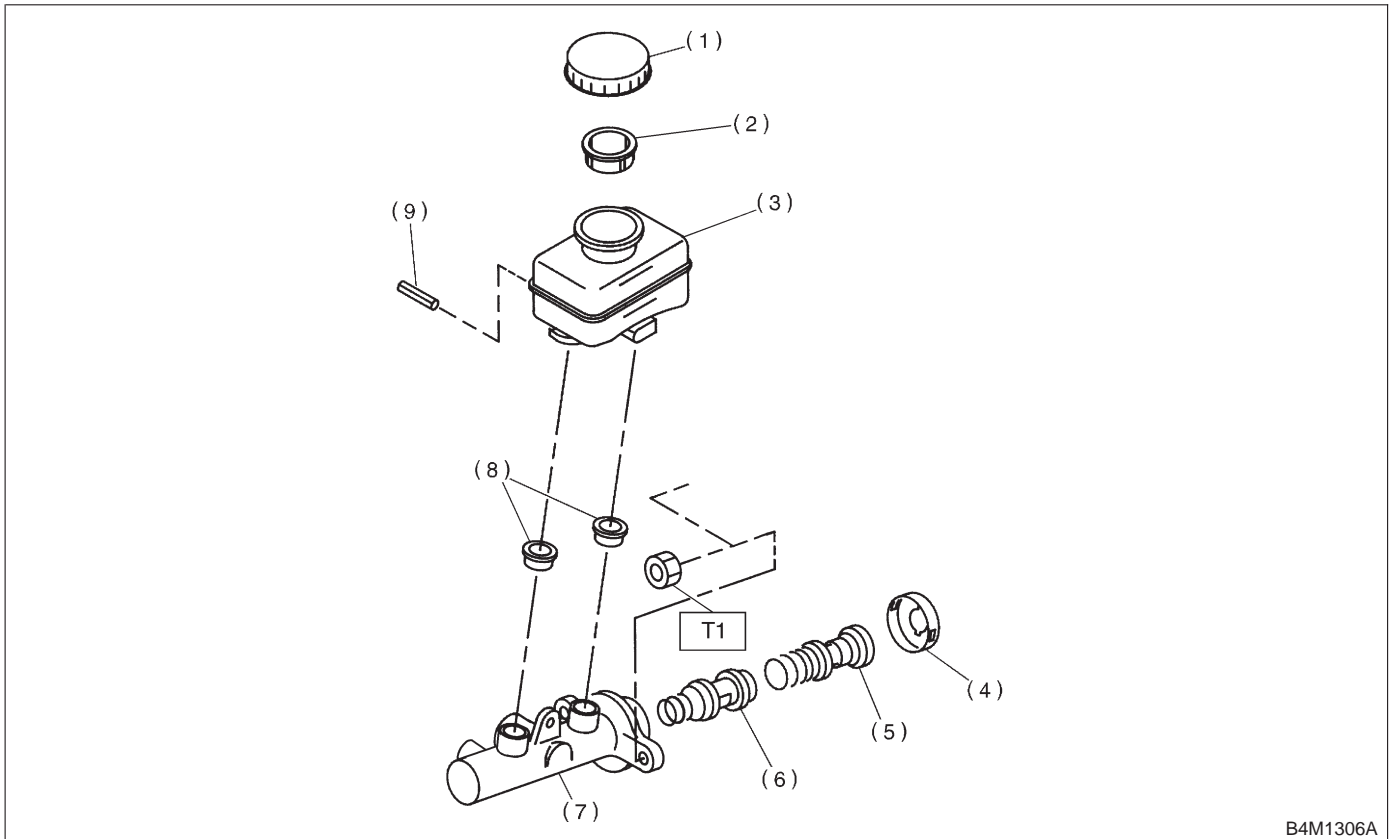

- (1) Cap
- (2) Filter
- (3) Reservoir tank
- (4) Piston retainer

- (5) Primary piston
- (6) Secondary piston
- (7) Cylinder body
- (8) Seal

- (9) Pin

**Tightening torque: N·m (kg·m, ft·lb)**  
**T1: 14±4 (1.4±0.4, 10.1±2.9)**