

16C3 : CHECK G SENSOR.

Read the select monitor display.

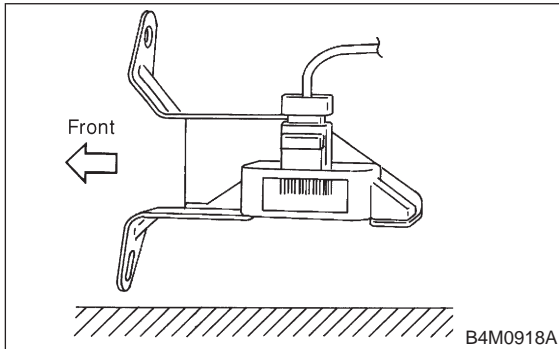

CHECK : Is the indicated reading 0.7 ± 0.2 V when G sensor is inclined backwards to 90° ?

YES : G sensor is normal.

NO : Replace G sensor.

17. Brake Pipe **AIRBAG****A: SUPPLEMENTAL RESTRAINT SYSTEM "AIRBAG"**

Airbag system wiring harness is routed near the center brake pipe.

CAUTION:

- All Airbag system wiring harness and connectors are colored yellow. Do not use electrical test equipment on these circuit.
- Be careful not to damage Airbag system wiring harness when servicing the center brake pipe.

B: REMOVAL AND INSTALLATION**CAUTION:**

- When removing and installing the brake pipe, make sure that it is not bent.
- After installing the brake pipe and hose, bleed the air.
- After installing the brake hose, make sure that it does not touch the tire or suspension assembly, etc.

Brake pipe tightening torque:

15^{+3}_{-2} N·m ($1.5^{+0.3}_{-0.2}$ kg·m, $10.8^{+2.2}_{-1.4}$ ft·lb)