

2. Clutch Cable

A: REMOVAL

- 1) Disconnect clutch cable from release lever.
- 2) Depress clutch pedal to the floor.
- 3) Remove clutch cable clamp from pedal bracket.

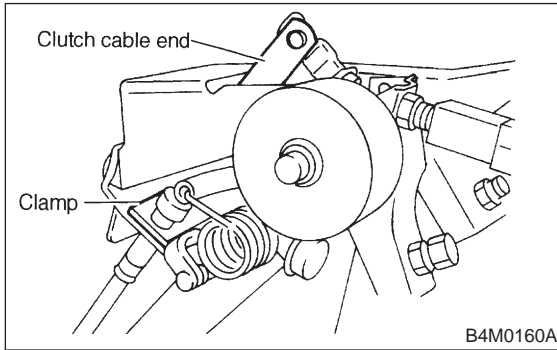

- 4) Disconnect clutch cable from pedal bracket and pedal end.
- 5) Remove clutch cable from body.

CAUTION:

Before removing clutch cable from toe board, remove grommet. Slowly remove clutch cable, being careful not to scratch it.

3. Accelerator Cable

A: REMOVAL

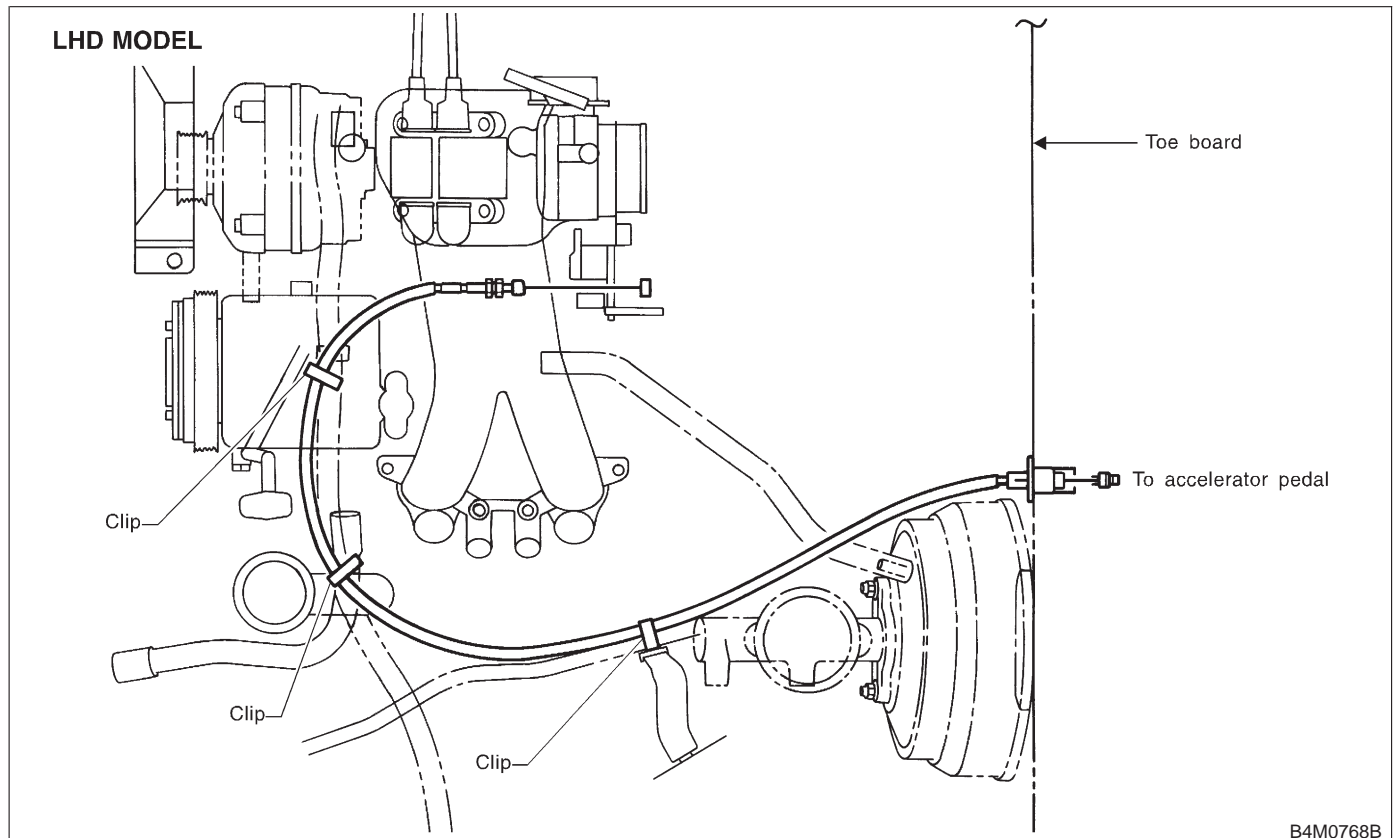

B: INSTALLATION

- 1) Clean clutch pedal fitting hole, and apply grease. Connect clutch cable to clutch pedal.

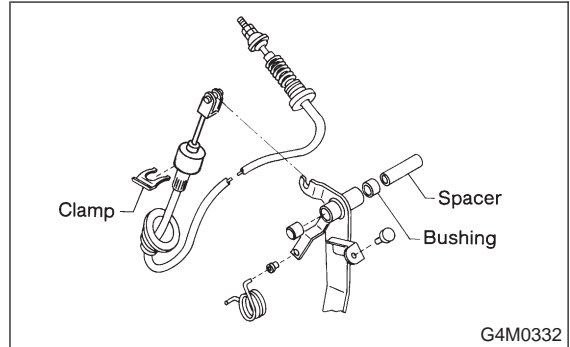

- 2) Fit clutch pedal to pedal bolt, and connect clutch cable to bracket with clamp.
- 3) Connect clutch cable end to pedal end.
- 4) Connect clutch cable from release lever.
- 5) Install grommet to toe board.
- 6) Adjust after cable installation. <Ref. to 4-5 [W1A2].>