

## 11. Installation of Wheel Assembly to Vehicle

- 1) Attach the wheel to the hub by aligning the wheel bolt hole with the hub bolt.
- 2) Temporarily attach the wheel nuts to the hub bolts. (In the case of aluminum wheel, use SUBARU genuine wheel nut for aluminum wheel.)
- 3) Manually tighten the nuts making sure the wheel hub hole is aligned correctly to the guide portion of hub.
- 4) Tighten the wheel nuts in a diagonal selection to the specified torque. Use a wheel nut wrench.

**Wheel nut tightening torque:**

**$88 \pm 10$  N·m ( $9 \pm 1$  kg·m,  $65 \pm 7$  ft·lb)**

**CAUTION:**

- Tighten the wheel nuts in two or three steps by gradually increasing the torque and working diagonally, until the specified torque is reached. For drum brake models, excess tightening of wheel nuts may cause wheels to “judder”.
- Do not depress the wrench with a foot; Always use both hands when tightening.
- Make sure the bolt, nut and the nut seating surface of the wheel are free from oils.

- 5) If a wheel is removed for replacement or for repair of a puncture, retighten the wheel nuts to the specified torque after running 1,000 km (600 miles).

## 12. Tire Rotation

If tires are maintained at the same positions for a long period of time, uneven wear results. Therefore, they should be periodically rotated. This lengthens service life of tires.

**CAUTION:**

**When rotating tires, replace unevenly worn or damaged tires with new ones.**

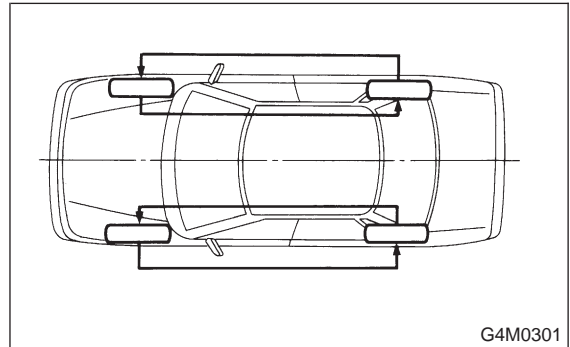

G4M0301