

3-2 [W20A0]

20. One-way Clutch Outer Race

SERVICE PROCEDURE

If the clearance is out of the specified range, select a proper retaining plate so that the standard clearance can be obtained.

Standard value:

1.0 — 1.4 mm (0.039 — 0.055 in)

Allowable limit:

2.0 mm (0.079 in)

Available retaining plates (Overrunning clutch)	
Part No.	Thickness mm (in)
31567AA120	8.0 (0.315)
31567AA130	8.2 (0.323)
31567AA140	8.4 (0.331)
31567AA150	8.6 (0.339)
31567AA160	8.8 (0.346)
31567AA170	9.0 (0.354)
31567AA180	9.2 (0.362)

9) Install the needle bearing, and secure with the snap ring.

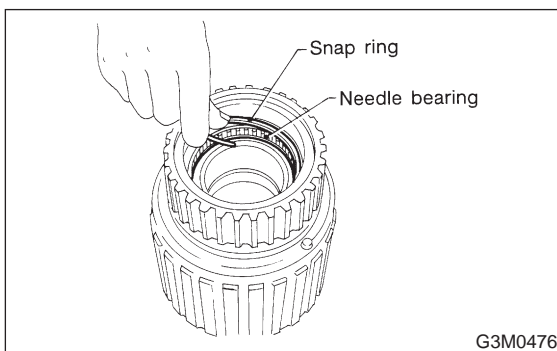

10) Install the one-way clutch (1-2) and plate, and secure with the snap ring.

NOTE:

Set the inner race. Make sure that the forward clutch is free in the clockwise direction and locked in the counterclockwise direction, as viewed from the front of the vehicle.

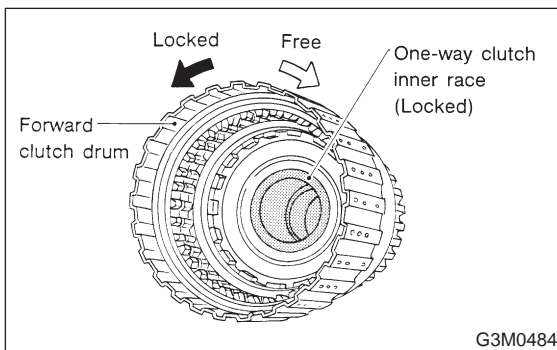

20. One-way Clutch Outer Race

A: DISASSEMBLY

Remove the snap ring. Then remove the one-way clutch (3-4).

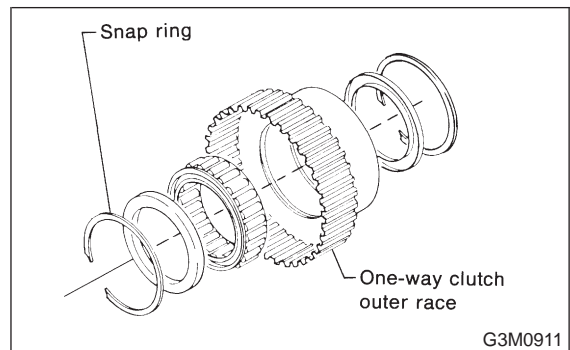

B: INSPECTION

Check the sliding surface and one-way clutch (3-4) for any harmful cuts, damage, or other faults.

C: ASSEMBLY

1) Assemble the one-way clutch (3-4), and secure with the snap ring.

NOTE:

Pay attention to the orientation of the one-way clutch (3-4).

2) Assemble the rear internal gear, and secure the outer race. Make sure that the internal gear is locked in the clockwise direction, and free to rotate in the counterclockwise direction.

