

9. Front Sub Sensor

A: REMOVAL AND INSTALLATION

CAUTION:

● If the front end of the vehicle body is damaged by a collision, be sure to check the left and right front sub sensors, even if the airbag was not inflated. If any damage to the sensor or any deformation of the sensor mount is found, replace with a new genuine part.

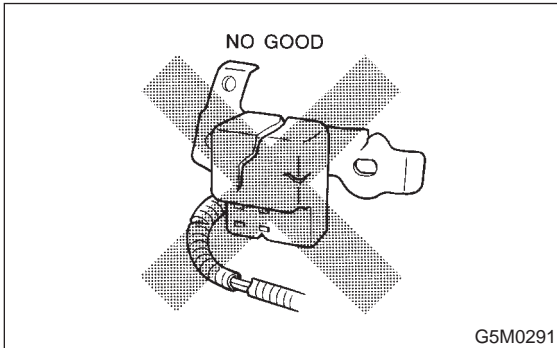

● When painting or performing sheet metal work on the front part of vehicle body, including the front wheel apron, front fender and front side frame, take utmost care not to apply dryer heat, painting mist, or the flame of the welding burner directly to the front sub sensors and wire harness of the airbag system.

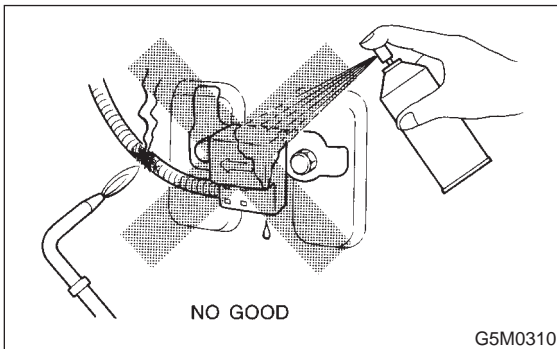

1. FRONT SUB SENSOR HARNESS

- 1) Turn ignition switch off.
- 2) Disconnect ground cable from battery and wait for at least 20 seconds before starting work.
- 3) Remove lower cover. <Ref. to 5-4 [W1A0].>
- 4) Remove instrument panel. <Ref. to 5-4 [W1A0].>

- 5) Disconnect front sub sensor connector (blue) from airbag main harness. <Ref. to 5-5 [M2F2].>

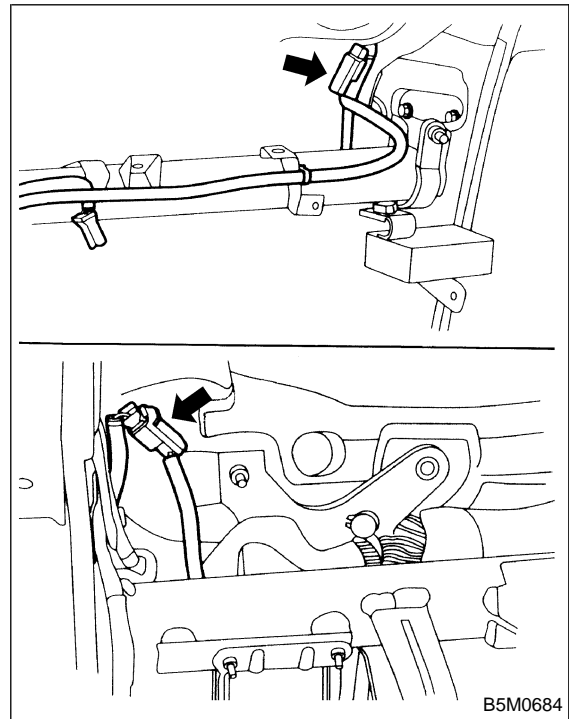

- 6) Remove front wheel and mud guard.
- 7) Disconnect connector from front sub sensor assembly. <Ref. to 5-5 [M2F4].>

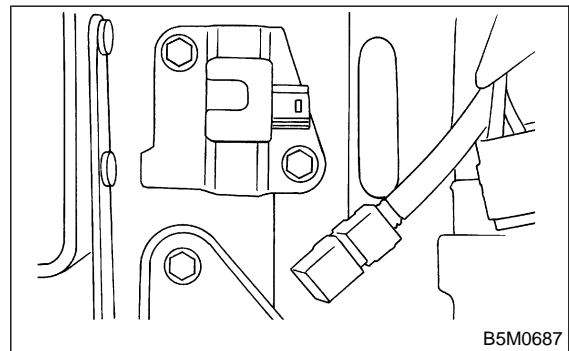

- 8) Remove wiring harness clips.
- 9) Remove grommet and then detach front sub sensor harness (A).

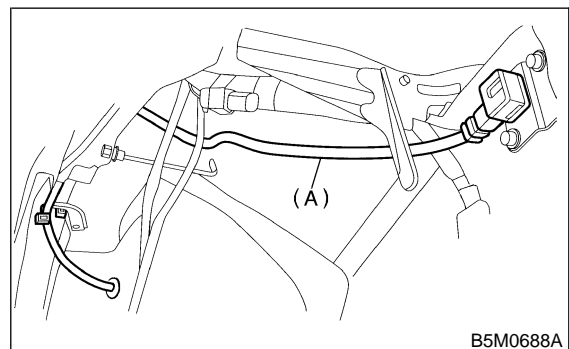

2. FRONT SUB SENSOR ASSEMBLY

- 1) Turn ignition switch off.
- 2) Disconnect ground cable from battery and wait for at least 20 seconds before starting work.
- 3) Remove front wheel and mud guard.
- 4) Disconnect connector from front sub sensor assembly. <Ref. to 5-5 [M2F4].>

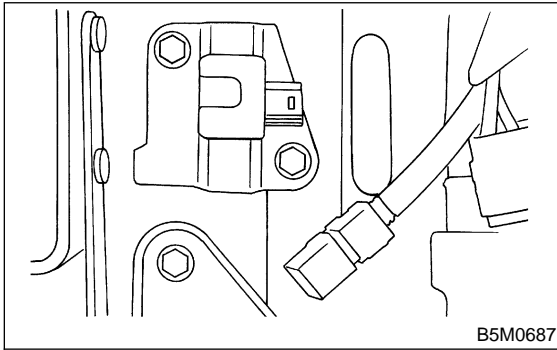

- 5) Remove front sub sensor (A).

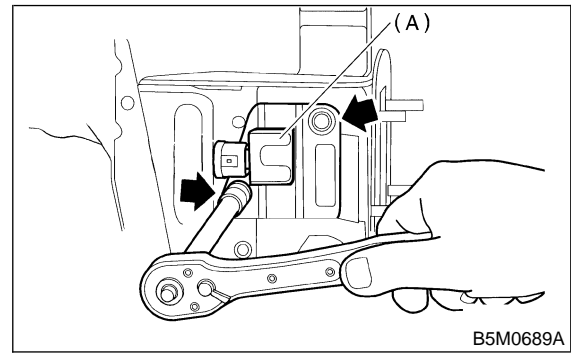

- 6) Installation is in the reverse order of removal.

MEMO: