

### 3. Canister

#### A: REMOVAL AND INSTALLATION

- 1) Lift-up the vehicle.
- 2) Loosen two clamps which hold two canister hoses, and disconnect evaporation three hoses from canister.

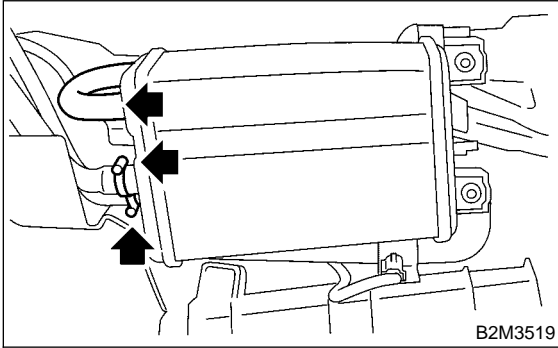

- 3) Remove canister from body.

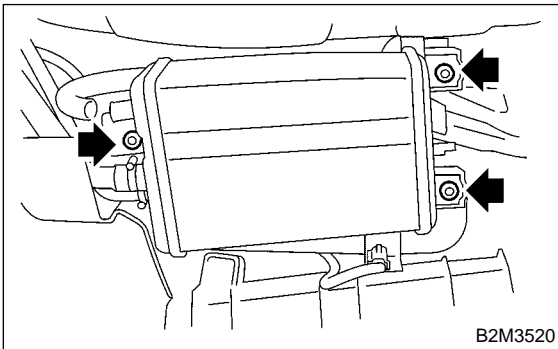

- 4) Installation is in the reverse order of removal.

**Tightening torque:**

**22.5±7 N·m (2.3±0.7 kg·m, 16.6±5.1 ft·lb)**

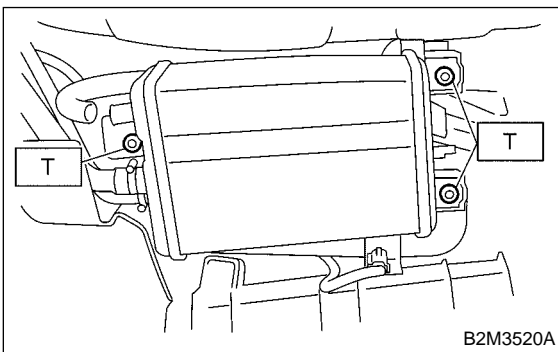

### 4. Purge Control Solenoid Valve

#### A: REMOVAL AND INSTALLATION

- 1) Disconnect battery ground cable.

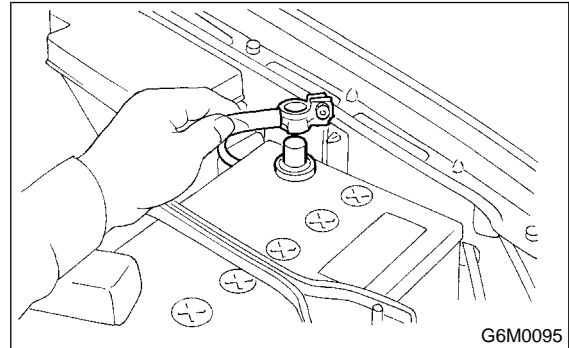

- 2) Remove bolt which installs purge control solenoid valve onto intake manifold.

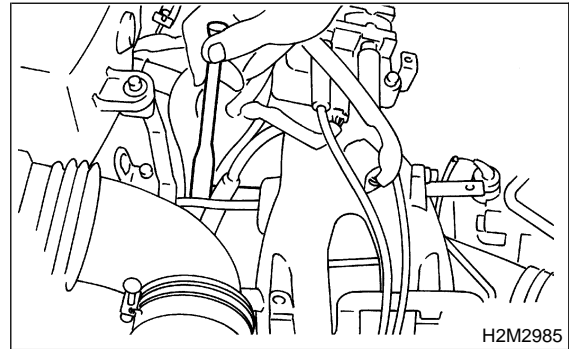

- 3) Take out purge control solenoid valve through the bottom of the intake manifold.
- 4) Disconnect connector and hoses from purge control solenoid valve.

