

## 9. Engine Coolant

### A: DRAINING OF ENGINE COOLANT

- 1) Lift-up the vehicle.
- 2) Remove under cover.

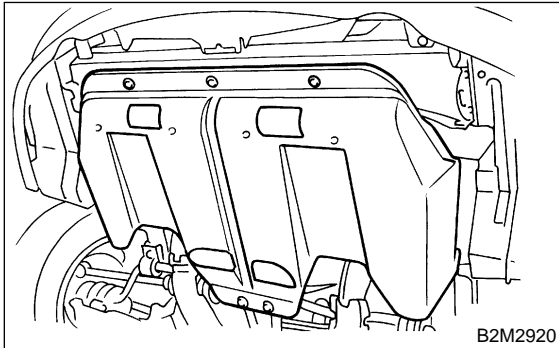

- 3) Remove drain cock to drain engine coolant into container.

**NOTE:**

Remove radiator cap so that engine coolant will drain faster.

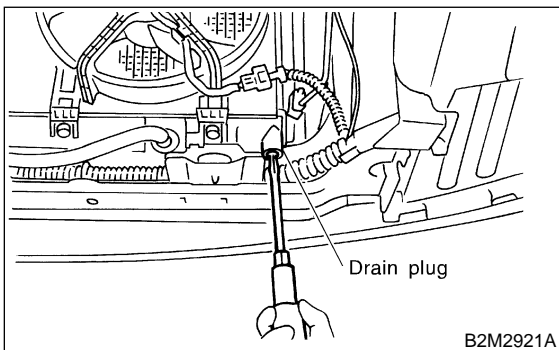

### B: FILLING OF ENGINE COOLANT

- 1) Fill engine coolant into radiator up to filler neck position.

**Coolant capacity (fill up to "FULL" level):**

**MT model;**

**Approx. 6.4 ℓ (6.8 US qt, 5.6 Imp qt)**

**AT model;**

**Approx. 6.3 ℓ (6.7 US qt, 5.5 Imp qt)**

**CAUTION:**

The SUBARU Genuine Coolant containing anti-freeze and anti-rust agents is especially made for SUBARU engine, which has an aluminum crankcase. Always use SUBARU Genuine Coolant, since other coolant may cause corrosion.

- 2) Fill engine coolant into reservoir tank up to upper level.

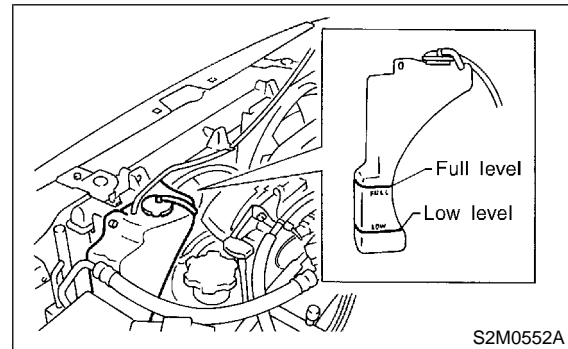

- 3) Attach radiator cap and reservoir tank cap properly.
- 4) Warm-up engine completely for more than five minutes at 2,000 to 3,000 rpm.
- 5) If engine coolant level drops in radiator, add engine coolant to filler neck position.
- 6) If engine coolant level drops from upper level of reservoir tank, add engine coolant to upper level.
- 7) Attach radiator cap and reservoir tank cap properly.

### 1. RELATIONSHIP OF SUBARU COOLANT CONCENTRATION AND FREEZING TEMPERATURE

The concentration and safe operating temperature of the SUBARU coolant is shown in the diagram. Measuring the temperature and specific gravity of the coolant will provide this information.

[Example]

If the coolant temperature is 25°C (77°F) and its specific gravity is 1.054, the concentration is 35% (point A), the safe operating temperature is -14°C (7°F) (point B), and the freezing temperature is -20°C (-4°F) (point C).

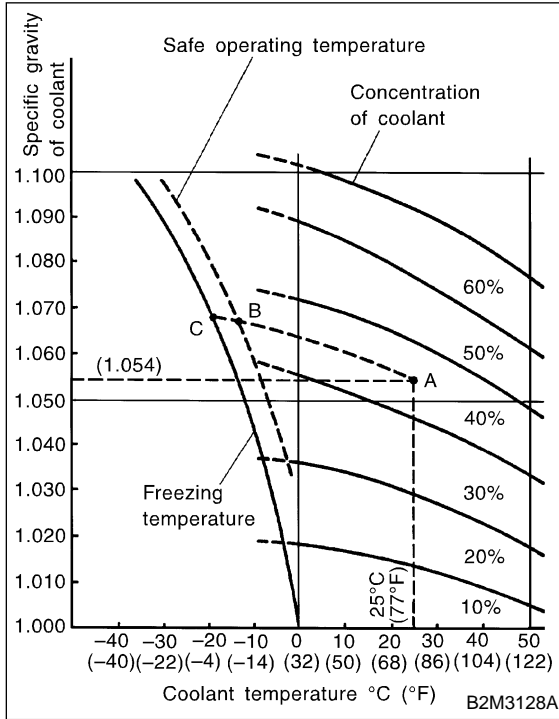

## 2. PROCEDURE TO ADJUST THE CONCENTRATION OF THE COOLANT

To adjust the concentration of the coolant according to temperature, find the proper fluid concentration in the above diagram and replace the necessary amount of coolant with an undiluted solution of SUBARU genuine coolant (concentration 50). The amount of coolant that should be replaced can be determined using the diagram.

[Example]

Assume that the coolant concentration must be increased from 25% to 40%. Find point A, where the 25% line of coolant concentration intersects with the 40% curve of the necessary coolant concentration, and read the scale on the vertical axis of the graph at height A. The quantity of coolant to be drained is 2.1 liters (2.2 US qt, 1.8 Imp qt). Drain 2.1 liters (2.2 US qt, 1.8 Imp qt) of coolant from the cooling system and add 2.1 liters (2.2 US qt, 1.8 Imp qt) of the undiluted solution of SUBARU coolant.

If a coolant concentration of 50% is needed, drain all the coolant and refill with the undiluted solution only.

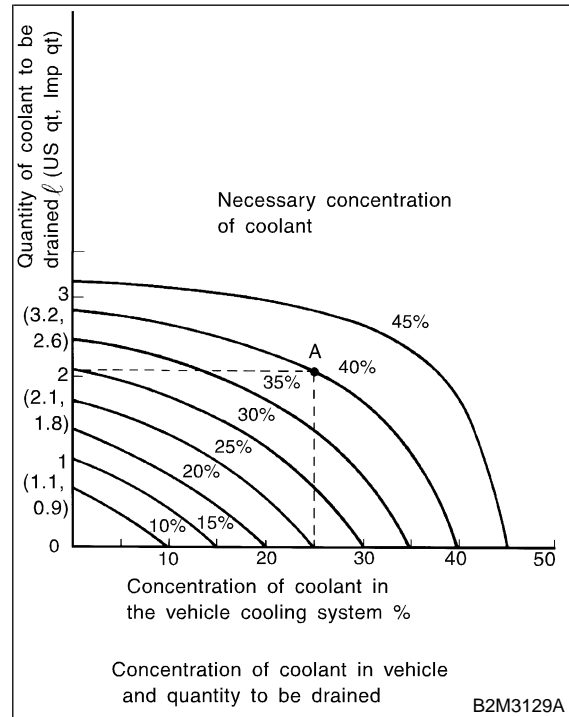

## C: CHECKING OF COOLING SYSTEM

- 1) Remove radiator cap, top off radiator, and attach tester to radiator in place of cap.

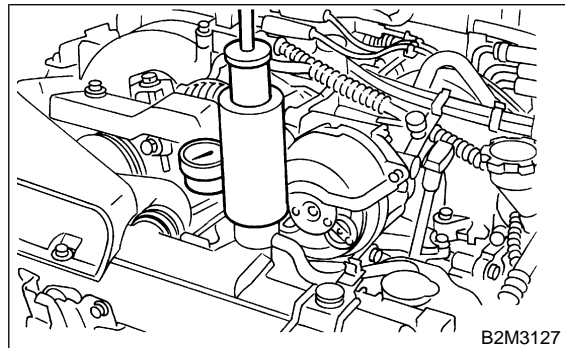

2) Apply a pressure of 157 kPa (1.6 kg/cm<sup>2</sup>, 23 psi) to radiator to check if:

- (1) Engine coolant leaks at/around radiator.
- (2) Engine coolant leaks at/around hoses or connections.

**CAUTION:**

- Engine should be off.

- Wipe engine coolant from check points in advance.
- Be careful to prevent engine coolant from spurting out when removing tester.
- Be careful also not to deform filler neck of radiator when installing or removing tester.