

2. Air Intake System

A: MT VEHICLES

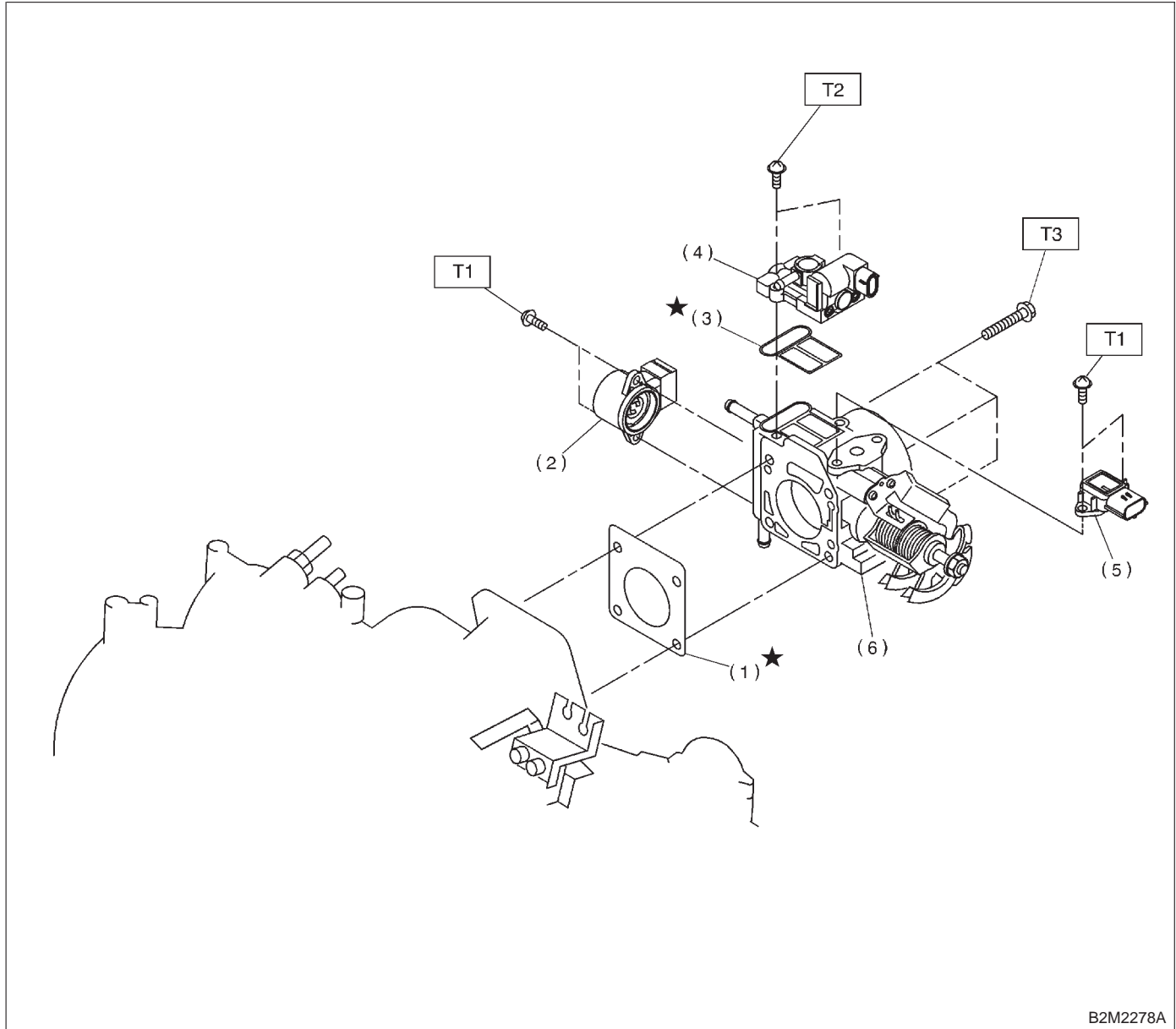

- (1) Gasket
- (2) Throttle position sensor
- (3) Gasket
- (4) Idle air control solenoid valve
- (5) Intake manifold pressure sensor
- (6) Throttle body

Tightening torque: N·m (kg·m, ft·lb)

T1: 2.2±0.2 (0.22±0.02, 1.6±0.1)

T2: 6.0±0.8 (0.61±0.08, 4.4±0.6)

T3: 22±2 (2.2±0.2, 15.9±1.4)

B: AT VEHICLES

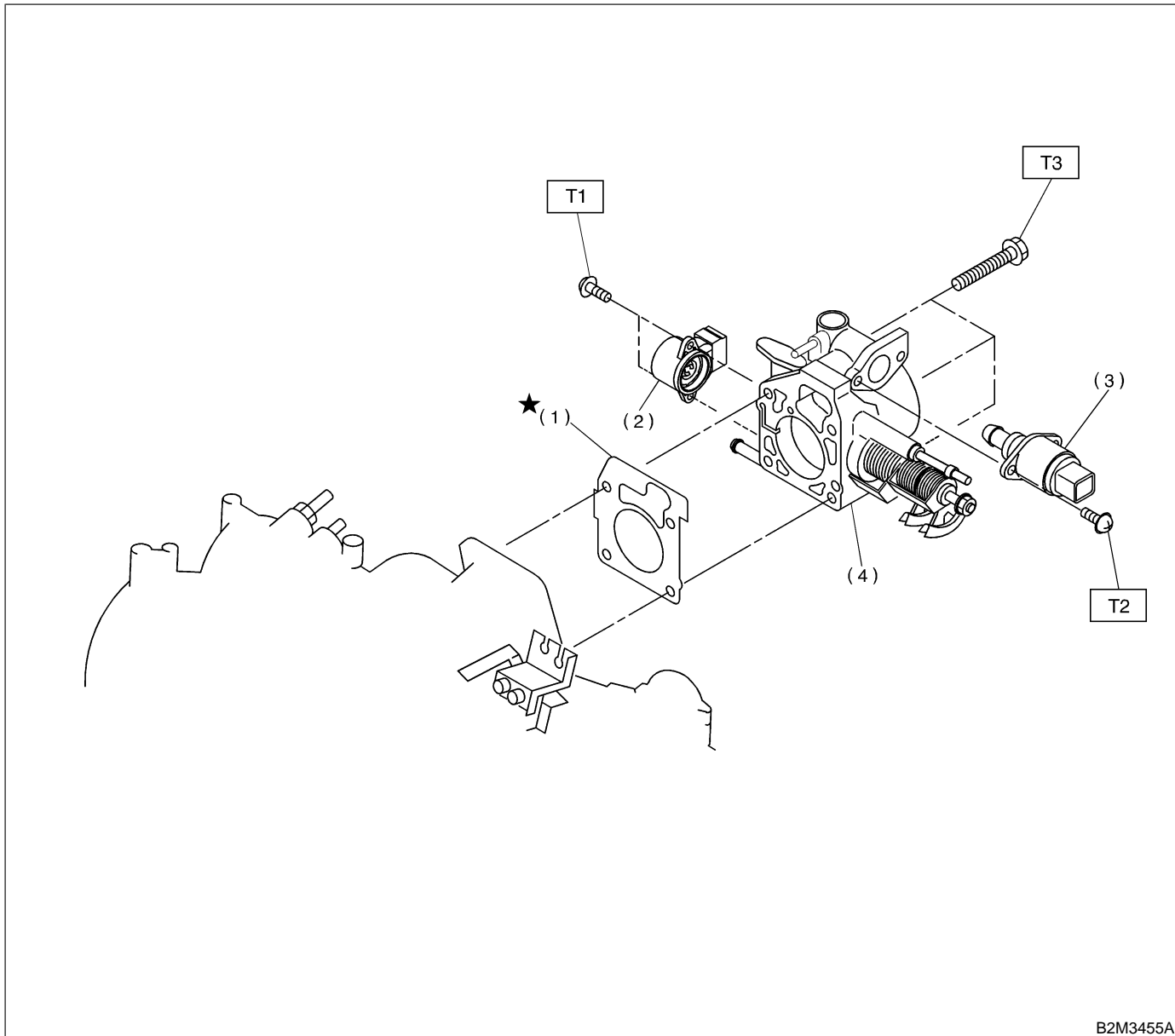

B2M3455A

- (1) Gasket
- (2) Throttle position sensor
- (3) Idle air control solenoid valve
- (4) Throttle body

Tightening torque: N·m (kg·m, ft·lb)

T1: 2.0±0.4 (0.2±0.04, 1.4±0.3)

T2: 6.0±0.8 (0.61±0.08, 4.4±0.6)

T3: 19±5 (1.9±0.5, 13.7±3.6)