

(3) Install rear exhaust pipe to center exhaust pipe.

Tightening torque:

18±5 N·m (1.8±0.5 kg·m, 13.0±3.6 ft·lb)

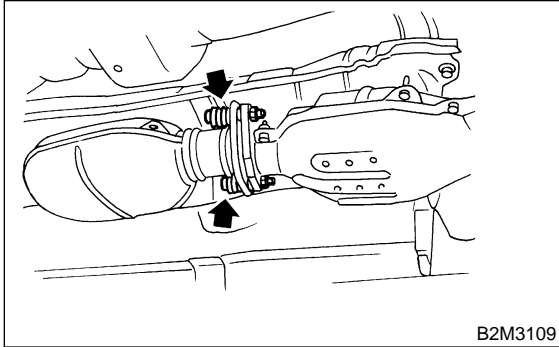

B2M3109

16) Install fuel filler pipe protector.

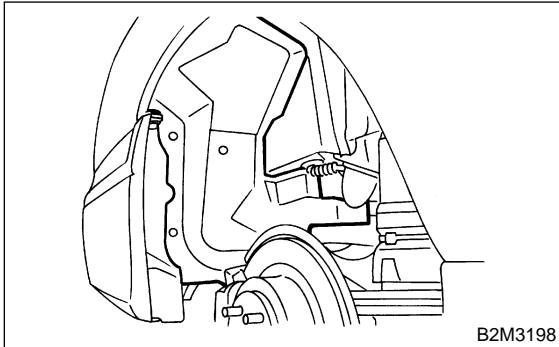

B2M3198

17) Install rear right wheel.

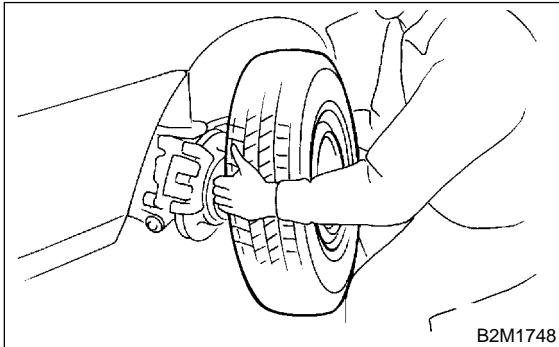

B2M1748

18) Lower the vehicle.

19) Tighten wheel nuts.

20) Connect battery ground terminal.

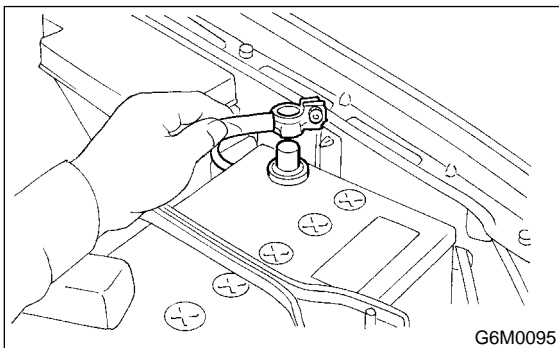

G6M0095

3. Fuel Pump

A: REMOVAL

WARNING:

- Place “NO FIRE” signs near the working area.
- Be careful not to spill fuel on the floor.
- During work procedures, if fuel tank is more than 3/4 full, be careful because fuel may spill.

NOTE:

Fuel pump assembly consists of fuel pump and fuel level sensor.

- 1) Release fuel pressure. <Ref. to 2-8 [W1A0].>
- 2) Open fuel filler flap lid and remove fuel filler cap.

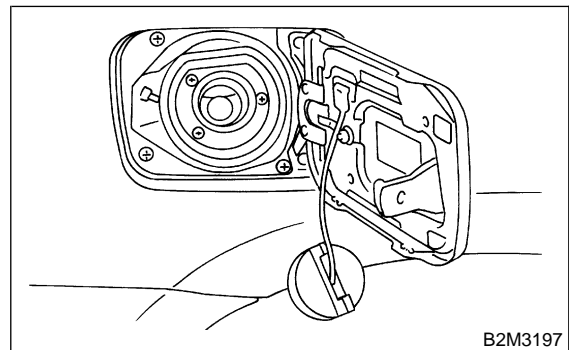

B2M3197

3) Disconnect battery ground cable.

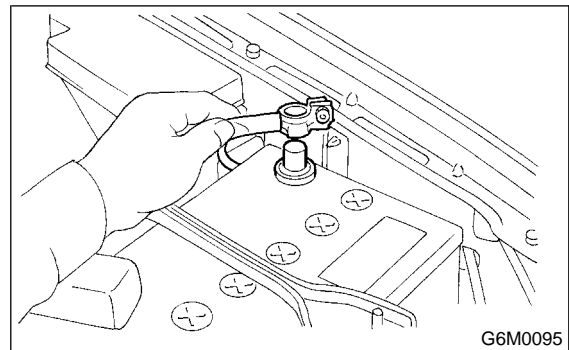

G6M0095

4) Lift-up the vehicle.

5) Remove front side fuel tank cover.

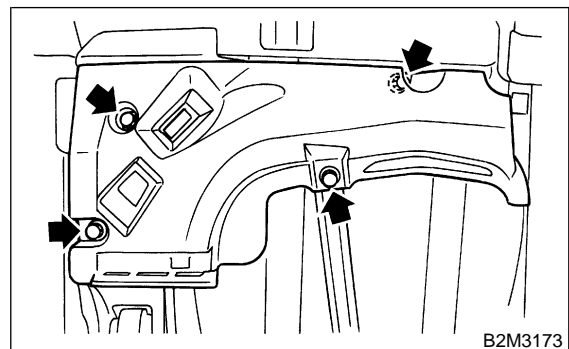

B2M3173

6) Drain fuel from fuel tank. Set a container under the vehicle and remove drain plug from fuel tank.

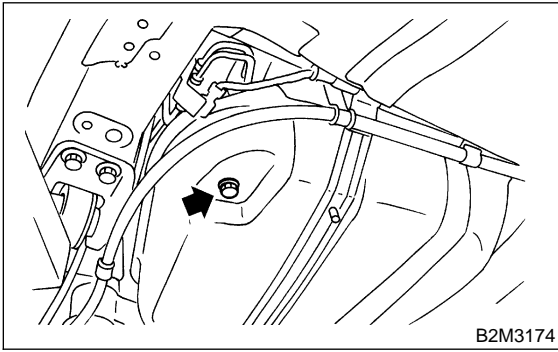

7) Tighten fuel drain plug and install front right side fuel tank cover.

Tightening torque:

$26 \pm 7 \text{ N}\cdot\text{m}$ ($2.65 \pm 0.7 \text{ kg}\cdot\text{m}$, $19.2 \pm 5.1 \text{ ft}\cdot\text{lb}$)

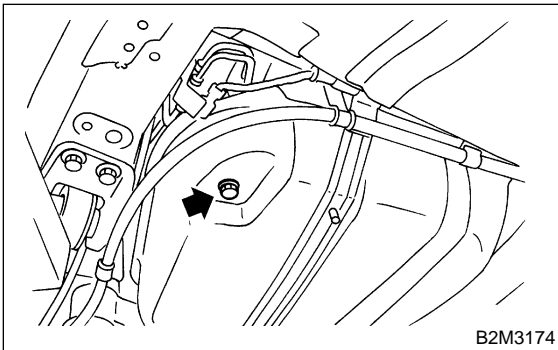

Tightening torque:

$18 \pm 5 \text{ N}\cdot\text{m}$ ($1.8 \pm 0.5 \text{ kg}\cdot\text{m}$, $13.0 \pm 3.6 \text{ ft}\cdot\text{lb}$)

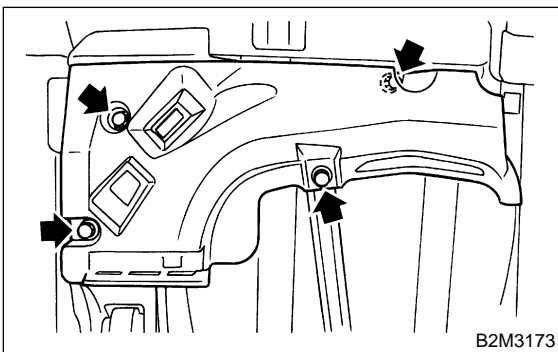

8) Raise rear seat and turn floor mat up.

9) Remove access hole lid.

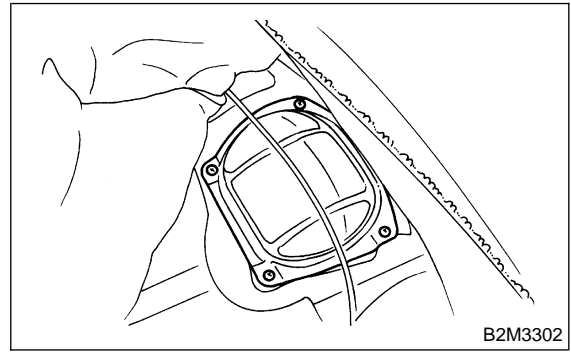

10) Disconnect connector from fuel pump.

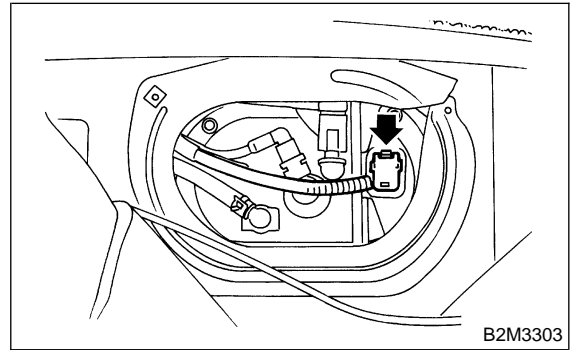

11) Move clips and then disconnect jet pump hose (C).

12) Disconnect quick connector and then disconnect fuel delivery hose (A) and return hose (B). <Ref. to 2-8 [W6A0].>

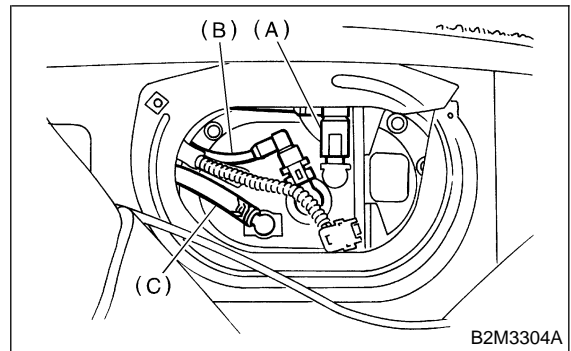

13) Remove nuts which install fuel pump assembly onto fuel tank.

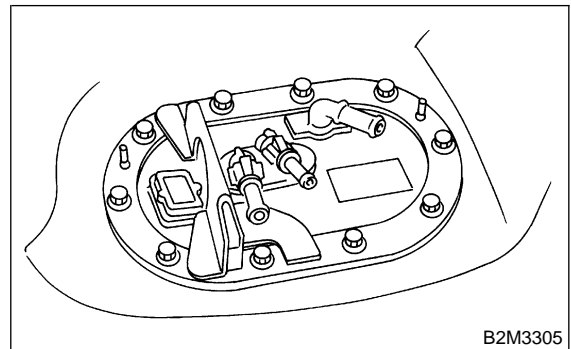

14) Take off fuel pump assembly from fuel tank.

B: DISASSEMBLY AND ASSEMBLY

1) Remove fuel pump and pump holder.

NOTE:

When disassembling pump holder, be careful as it is installed with two pawls.

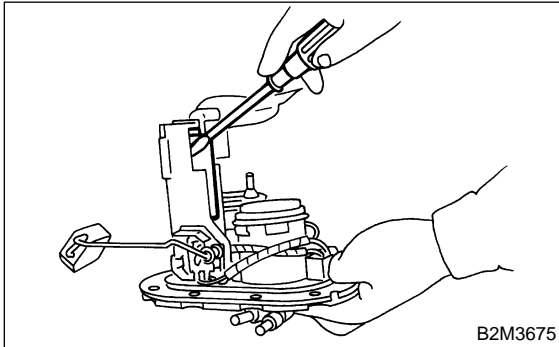

2) Disconnect connector from fuel pump.

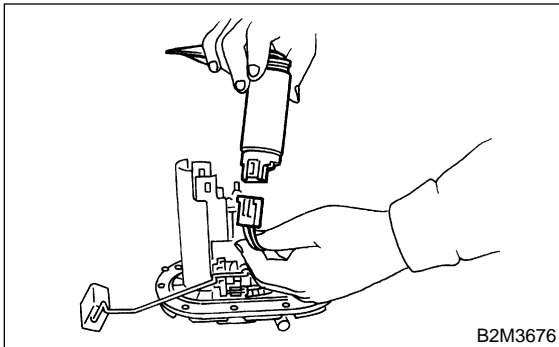

3) Installation is in the reverse order of removal.

C: INSPECTION

Connect lead harness to connector terminal of fuel pump and apply battery power supply to check whether the pump operate.

WARNING:

- Wipe off the fuel completely.
- Keep battery as far apart from fuel pump as possible.
- Be sure to turn the battery supply ON and OFF on the battery side.
- Do not run fuel pump for a long time under non-load condition.

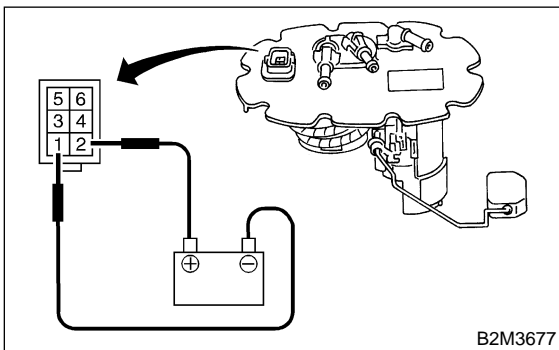

D: INSTALLATION

Installation is in the reverse order of removal. Do the following:

- (1) Always use new gaskets.
- (2) Ensure sealing portion is free from fuel or foreign particles before installation.
- (3) Tighten nuts in alphabetical sequence shown in figure to specified torque.

Tightening torque:

5.9±1.5 N·m (0.6±0.15 kg·m, 4.3±1.1 ft·lb)

