

3. Diagnosis System

A: CHECK ENGINE MALFUNCTION INDICATOR LAMP (MIL)

1. ACTIVATION OF CHECK ENGINE MALFUNCTION INDICATOR LAMP (MIL)

1) When ignition switch is turned to ON (engine off), the CHECK ENGINE malfunction indicator lamp (MIL) in the combination meter illuminates.

NOTE:

If the MIL does not illuminate, perform diagnostics of the CHECK ENGINE light circuit or the combination meter circuit. <Ref. to 2-7 [T700].>

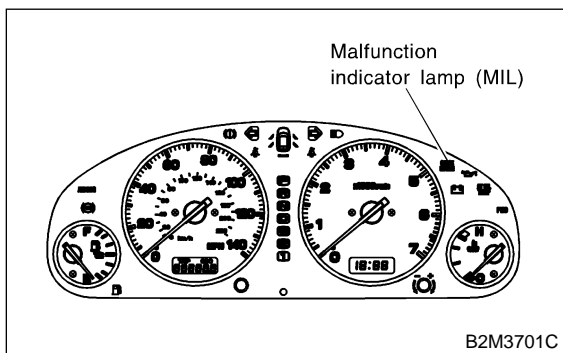

2) After starting the engine, the MIL goes out. If it does not, either the engine or the emission control system is malfunctioning.

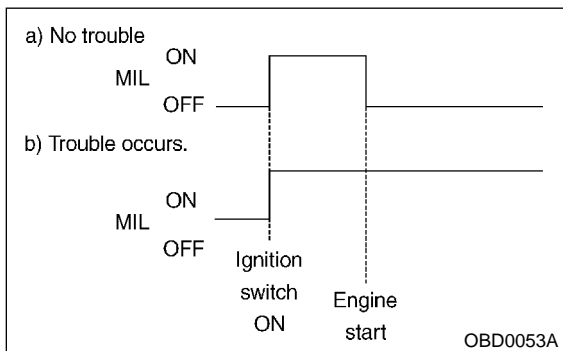

3) If the diagnosis system senses a misfire which could damage the catalyzer, the MIL will blink at a cycle of 1 Hz.

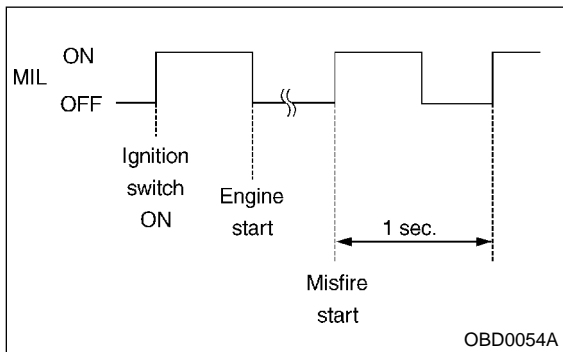

4) When ignition switch is turned to ON (engine off) or to "START" with the test mode connector connected, the MIL blinks at a cycle of 3 Hz.

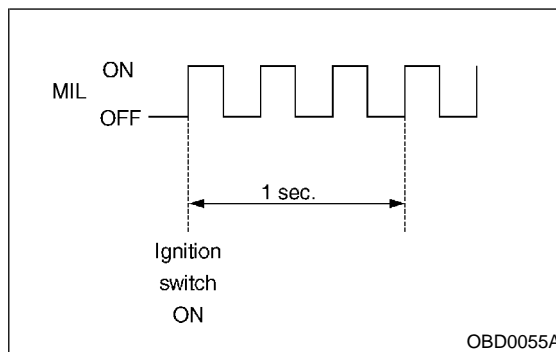

B: OBD-II GENERAL SCAN TOOL

1. HOW TO USE OBD-II GENERAL SCAN TOOL

- 1) Prepare a general scan tool (OBD-II general scan tool) required by SAE J1978.
- 2) Open the cover and connect the OBD-II general scan tool to the data link connector located in the lower portion of the instrument panel (on the driver's side).

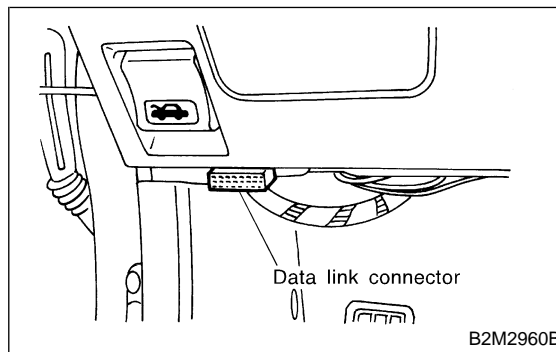

3) Using the OBD-II general scan tool, call up diagnostic trouble code(s) and freeze frame data. OBD-II general scan tool functions consist of:

- (1) MODE \$01: Current powertrain diagnostic data
- (2) MODE \$02: Powertrain freeze frame data
- (3) MODE \$03: Emission-related powertrain diagnostic trouble codes
- (4) MODE \$04: Clear/Reset emission-related diagnostic information

Read out data according to repair procedures. (For detailed operation procedures, refer to the OBD-II General Scan Tool Operation Manual.)

NOTE:

For details concerning diagnostic trouble codes, refer to the DIAGNOSTIC TROUBLE CODE (DTC) LIST.

- MT vehicles: <Ref. to 2-7 [T10A0].>
- AT vehicles: <Ref. to 2-7 [T11A0].>

2. DATA LINK CONNECTOR (FOR OBD-II GENERAL SCAN TOOL AND SUBARU SELECT MONITOR)

- 1) This connector is used both for OBD-II general scan tools and the Subaru Select Monitor.
- 2) Terminal No. 4 to No. 6 of the data link connector is used for the Subaru Select Monitor signal.

CAUTION:

Do not connect any scan tools other than the OBD-II general scan tools and the Subaru Select Monitor, because the circuit for the Subaru Select Monitor may be damaged.

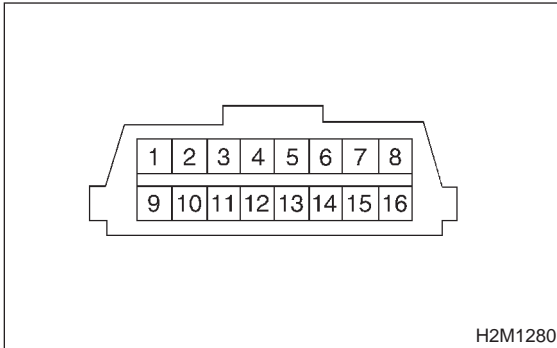

Terminal No.	Contents	Terminal No.	Contents
1	Power supply	9	Blank
2	Blank	10	K line of ISO 9141 CARB
3	Blank	11	Blank
4	Subaru Select Monitor signal (ECM to Subaru Select Monitor)*	12	Ground
5	Subaru Select Monitor signal (Subaru Select Monitor to ECM)*	13	Ground
6	Line end check signal 1	14	Blank
7	Blank	15	Blank
8	Line end check signal 2 (MT vehicles)	16	Blank

*: Circuit only for Subaru Select Monitor

3. CURRENT POWERTRAIN DIAGNOSTIC DATA (MODE \$01)

Refers to data denoting the current operating condition of analog input/output, digital input/output and/or the powertrain system.

A list of the support data and PID (Parameter Identification) codes are shown in the following table.

PID	Data	Unit of measure
01	Number of emission-related powertrain trouble codes and MIL status	ON/OFF
03	Fuel system control status	—
04	Calculated engine load value	%
05	Engine coolant temperature	°C
06	Short term fuel trim	%
07	Long term fuel trim	%
0B	Intake manifold absolute pressure	kPa
0C	Engine revolution	rpm
0D	Vehicle speed	km/h
0E	Ignition timing advance	°
10	Air flow rate from pressure sensor	g/sec
11	Throttle valve opening angle	%
13	Check whether oxygen sensor is installed.	—
14	Oxygen sensor output voltage and short term fuel trim associated with oxygen sensor—bank 1	V and %
15	Oxygen sensor output voltage and short term fuel trim associated with oxygen sensor—bank 2	V and %
1C	On-board diagnosis system	—

NOTE:

Refer to OBD-II general scan tool manufacturer's instruction manual to access generic OBD-II PIDs (MODE \$01).

4. POWERTRAIN FREEZE FRAME DATA (MODE \$02)

Refers to data denoting the operating condition when trouble is sensed by the on-board diagnosis system.

A list of the support data and PID (Parameter Identification) codes are shown in the following table.

PID	Data	Unit of measure
02	Trouble code that caused CARB required freeze frame data storage	—
03	Fuel system control status	—
04	Calculated engine load value	%
05	Engine coolant temperature	°C
06	Short term fuel trim	%
07	Long term fuel trim	%
0B	Intake manifold absolute pressure	kPa
0C	Engine revolution	rpm
0D	Vehicle speed	km/h

NOTE:

Refer to OBD-II general scan tool manufacturer's instruction manual to access freeze frame data (MODE \$02).

5. EMISSION-RELATED POWERTRAIN DIAGNOSTIC TROUBLE CODE (MODE \$03)

Refers to data denoting emission-related powertrain diagnostic trouble codes.

For details concerning diagnostic trouble codes, refer to the DIAGNOSTIC TROUBLE CODE (DTC) LIST.

- MT vehicles: <Ref. to 2-7 [T10A0].>
- AT vehicles: <Ref. to 2-7 [T11A0].>

NOTE:

Refer to OBD-II general scan tool manufacturer's instruction manual to access emission-related powertrain diagnostic trouble codes (MODE \$03).

6. CLEAR/RESET EMISSION-RELATED DIAGNOSTIC INFORMATION (MODE \$04)

Refers to the mode used to clear or reset emission-related diagnostic information (OBD-II trouble diagnostic information).

NOTE:

Refer to OBD-II general scan tool manufacturer's instruction manual to clear or reset emission-related diagnostic information (MODE \$04).

C: SUBARU SELECT MONITOR

1. HOW TO USE SUBARU SELECT MONITOR

- 1) Prepare Subaru Select Monitor kit.

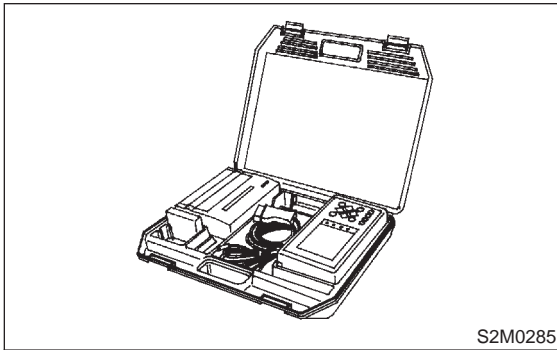

- 2) Connect diagnosis cable to Subaru Select Monitor.

- 3) Insert cartridge into Subaru Select Monitor.
<Ref. to 1-6 [G1100].>

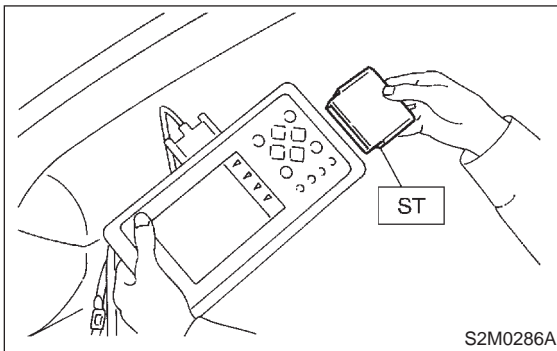

- 4) Connect Subaru Select Monitor to data link connector.

- (1) Data link connector located in the lower portion of the instrument panel (on the driver's side).

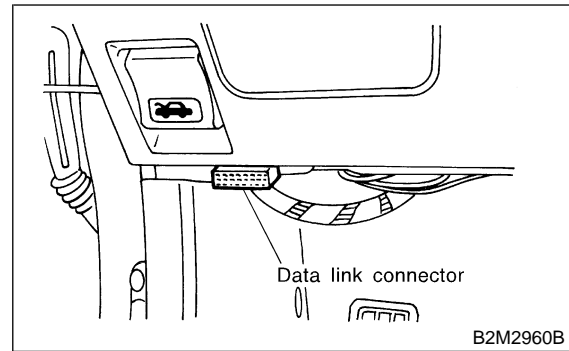

- (2) Connect diagnosis cable to data link connector.

CAUTION:

Do not connect scan tools except for Subaru Select Monitor and OBD-II general scan tool.

- 5) Turn ignition switch to ON (engine OFF) and Subaru Select Monitor switch to ON.

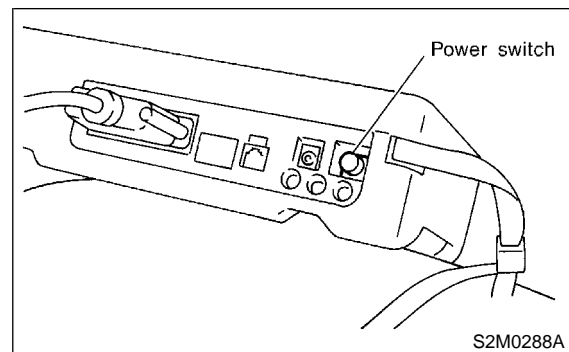

- 6) Using Subaru Select Monitor, call up diagnostic trouble code(s) and various data, then record them.

2. READ DIAGNOSTIC TROUBLE CODE (DTC) SHOWN ON DISPLAY FOR ENGINE. (NORMAL MODE)

- 1) On the 「Main Menu」 display screen, select the {Each System Check} and press the [YES] key.
- 2) On the 「System Selection Menu」 display screen, select the {Engine Control System} and press the [YES] key.

- 3) Press the [YES] key after displayed the information of engine type.
- 4) On the 「Engine Diagnosis」 display screen, select the {Diagnostic Code(s) Display} and press the [YES] key.
- 5) On the 「Diagnostic Code(s) Display」 display screen, select the {Current Diagnostic Code(s)} or {History Diagnostic Code(s)} and press the [YES] key.

NOTE:

- For detailed operation procedure, refer to the SUBARU SELECT MONITOR OPERATION MANUAL.
- For detailed concerning diagnostic trouble codes, refer to the DIAGNOSTIC TROUBLE CODE (DTC) LIST.
 - MT vehicles: <Ref. to 2-7 [T10A0].>
 - AT vehicles: <Ref. to 2-7 [T11A0].>

3. READ DIAGNOSTIC TROUBLE CODE (DTC) SHOWN ON DISPLAY FOR ENGINE. (OBD MODE)

- 1) On the 「Main Menu」 display screen, select the {2. Each System Check} and press the [YES] key.
- 2) On the 「System Selection Menu」 display screen, select the {Engine Control System} and press the [YES] key.
- 3) Press the [YES] key after displayed the information of engine type.
- 4) On the 「Engine Diagnosis」 display screen, select the {OBD System} and press the [YES] key.
- 5) On the 「OBD Menu」 display screen, select the {Diagnosis Code(s) Display} and press the [YES] key.
- 6) Make sure that a diagnostic trouble code (DTC) is shown on the display screen.

NOTE:

- For detailed operation procedure, refer to the SUBARU SELECT MONITOR OPERATION MANUAL.
- For detailed concerning diagnostic trouble codes, refer to the DIAGNOSTIC TROUBLE CODE (DTC) LIST.
 - MT vehicles: <Ref. to 2-7 [T10A0].>
 - AT vehicles: <Ref. to 2-7 [T11A0].>

4. READ CURRENT DATA SHOWN ON DISPLAY FOR ENGINE. (NORMAL MODE)

- 1) On the 「Main Menu」 display screen, select the {Each System Check} and press the [YES] key.
 - 2) On the 「System Selection Menu」 display screen, select the {Engine Control System} and press the [YES] key.
 - 3) Press the [YES] key after displayed the information of engine type.
 - 4) On the 「Engine Diagnosis」 display screen, select the {Current Data Display & Save} and press the [YES] key.
 - 5) On the 「Data Display Menu」 display screen, select the {Data Display} and press the [YES] key.
 - 6) Using the scroll key, move the display screen up or down until the desired data is shown.
- A list of the support data is shown in the following table.

Contents	Display	Unit of measure
Battery voltage	Battery Voltage	V
Vehicle speed signal	Vehicle Speed	km/h or MPH
Engine speed signal	Engine Speed	rpm
Engine coolant temperature signal	Coolant Temp.	°C or °F
Ignition timing signal	Ignition Timing	deg
Throttle position signal	Throttle Opening Angle	%
Throttle position signal	Throttle Sensor Voltage	V
Injection pulse width	Fuel Injection #1 Pulse	ms
Idle air control signal*2	ISC Valve Duty Ratio	%
Idle air control signal*1	ISC Valve Step	STEP
Engine load data	Engine Load	%
Front oxygen (A/F) sensor output signal	A/F Sensor #1	—
Front oxygen (A/F) sensor resistance	A/F Sensor #1 Resistance	Ω
Rear oxygen sensor output signal	Rear O2 Sensor	V
Short term fuel trim	A/F Correction #1	%
Knock sensor signal	Knocking Correction	deg
Atmospheric absolute pressure signal	Atmosphere Pressure	mmHg or kPa or inHg or psi
Intake manifold relative pressure signal	Mani. Relative Pressure	mmHg or kPa or inHg or psi
Intake manifold absolute pressure signal	Mani. Absolute Pressure	mmHg or kPa or inHg or psi
A/F correction (short term fuel trim) by rear oxygen sensor	A/F Correction #3	%
Long term whole fuel trim	A/F Learning #1	%
Front oxygen (A/F) sensor heater current	A/F Heater #1	A
Rear oxygen sensor heater voltage	Rear O2 Heater Voltage	V
Canister purge control solenoid valve duty ratio	CPC Valve Duty Ratio	%
Fuel tank pressure signal	Fuel Tank Pressure	mmHg or kPa or inHg or psi
Fuel temperature signal	Fuel Temp.	°C or °F
Fuel level signal	Fuel Level	V
Intake air temperature signal	Intake Air Temp.	°C or °F
Learned ignition timing	Learned Ignition Timing	V
Ignition switch signal	Ignition Switch	ON or OFF
Test mode connector signal	Test Mode Signal	ON or OFF
Neutral position switch signal	Neutral Position Switch	ON or OFF
Air conditioning switch signal	A/C Switch	ON or OFF
Air conditioning relay signal	A/C Relay	ON or OFF
Radiator main fan relay signal	Radiator Fan Relay #1	ON or OFF
Fuel pump relay signal	Fuel Pump Relay	ON or OFF
Knocking signal	Knocking Signal	ON or OFF
Radiator sub fan relay signal	Radiator Fan Relay #2	ON or OFF

Contents	Display	Unit of measure
Engine torque control signal #1	Torque Control Signal #1	ON or OFF
Engine torque control signal #2	Torque Control Signal #2	ON or OFF
Engine torque control permission signal	Torque Control Permit	ON or OFF
Rear oxygen sensor rich signal	Rear O2 Rich Signal	ON or OFF
Pressure control solenoid valve	PCV Solenoid Valve	ON or OFF
Drain valve	Vent. Solenoid Valve	ON or OFF
Starter switch signal	Starter Switch Signal	ON or OFF
Idle switch signal	Idle Switch Signal	ON or OFF
Crankshaft position sensor signal	Crankshaft Position Sig.	ON or OFF
Camshaft position sensor signal	Camshaft Position Sig.	ON or OFF
Rear defogger switch signal	Rear Defogger Switch	ON or OFF
Blower fan switch signal	Blower Fan Switch	ON or OFF
Small light switch signal	Small Light Switch	ON or OFF
Air assist injector solenoid valve signal	AAI Solenoid Valve	ON or OFF

*1: AT vehicles

*2: MT vehicles

NOTE:

For detailed operation procedure, refer to the SUBARU SELECT MONITOR OPERATION MANUAL.

5. READ CURRENT DATA SHOWN ON DISPLAY FOR ENGINE. (OBD MODE)

- 1) On the 「Main Menu」 display screen, select the {Each System Check} and press the [YES] key.
 - 2) On the 「System Selection Menu」 display screen, select the {Engine Control System} and press the [YES] key.
 - 3) Press the [YES] key after displayed the information of engine type.
 - 4) On the 「Engine Diagnosis」 display screen, select the {OBD System} and press the [YES] key.
 - 5) On the 「OBD Menu」 display screen, select the {Current Data Display & Save} and press the [YES] key.
 - 6) On the 「Data Display Menu」 display screen, select the {Data Display} and press the [YES] key.
 - 7) Using the scroll key, move the display screen up or down until the desired data is shown.
- A list of the support data is shown in the following table.

Contents	Display	Unit of measure
Number of diagnosis code	Number of Diagnosis Code	—
Malfunction indicator lamp status	MIL Status	ON or OFF
Monitoring test of misfire	Misfire monitoring	ON or OFF
Monitoring test of fuel system	Fuel system monitoring	ON or OFF
Monitoring test of comprehensive component	Component monitoring	ON or OFF
Test of catalyst	Catalyst Diagnosis	ON or OFF
Test of heated catalyst	Heated catalyst	ON or OFF
Test of evaporative emission purge control system	Evaporative purge system	ON or OFF
Test of secondary air system	Secondary air system	ON or OFF
Test of air conditioning system refrigerant	A/C system refrigerant	ON or OFF
Test of oxygen sensor	Oxygen sensor	ON or OFF
Test of oxygen sensor heater	Oxygen sensor heater	ON or OFF
Air fuel ratio control system for bank 1	Fuel System for Bank 1	ON or OFF
Engine load data	Engine Load	%
Engine coolant temperature signal	Coolant Temp.	°C or °F
Short term fuel trim by front oxygen (A/F) sensor	Short term fuel trim B1	%
Long term fuel trim by front oxygen (A/F) sensor	Long term fuel trim B1	%
Intake manifold absolute pressure signal	Mani. Absolute Pressure	mmHg or kPa or inHg or psi
Engine speed signal	Engine Speed	rpm
Vehicle speed signal	Vehicle Speed	km/h or MPH
Ignition timing advance for #1 cylinder	Ignition timing adv. #1	°
Intake air temperature signal	Intake Air Temp.	°C or °F
Throttle position signal	Throttle Opening Angle	%
A/F sensor equipment	A/F sensor	ON or OFF
Rear oxygen sensor output signal	Oxygen Sensor #12	V
Air fuel ratio correction by rear oxygen sensor	Short term fuel trim #12	%
On-board diagnostic system	OBD System	—

NOTE:

For detailed operation procedure, refer to the SUBARU SELECT MONITOR OPERATION MANUAL.

6. READ FREEZE FRAME DATA SHOWN ON DISPLAY FOR ENGINE. (OBD MODE)

- 1) On the 「Main Menu」 display screen, select the {Each System Check} and press the [YES] key.
 - 2) On the 「System Selection Menu」 display screen, select the {Engine Control System} and press the [YES] key.
 - 3) Press the [YES] key after displayed the information of engine type.
 - 4) On the 「Engine Diagnosis」 display screen, select the {OBD System} and press the [YES] key.
 - 5) On the 「OBD Menu」 display screen, select the {Freeze Frame Data} and press the [YES] key.
- A list of the support data is shown in the following table.

Contents	Display	Unit of measure
Diagnostic trouble code (DTC) for freeze frame data	Freeze frame data	DTC
Air fuel ratio control system for bank 1	Fuel system for Bank1	ON or OFF
Engine load data	Engine Load	%
Engine coolant temperature signal	Coolant Temp.	°C or °F
Short term fuel trim by front oxygen (A/F) sensor	Short term fuel trim B1	%
Long term fuel trim by front oxygen (A/F) sensor	Long term fuel trim B1	%
Intake manifold absolute pressure signal	Mani. Absolute Pressure	mmHg or kPa or inHg or psi
Engine speed signal	Engine Speed	rpm
Vehicle speed signal	Vehicle Speed	km/h or MPH

NOTE:

For detailed operation procedure, refer to the SUBARU SELECT MONITOR OPERATION MANUAL.

7. READ OXYGEN SENSOR MONITORING TEST RESULTS DATA SHOWN ON DISPLAY FOR ENGINE. (OBD MODE)

- 1) On the 「Main Menu」 display screen, select the {Each System Check} and press the [YES] key.
 - 2) On the 「System Selection Menu」 display screen, select the {Engine Control System} and press the [YES] key.
 - 3) Press the [YES] key after displayed the information of engine type.
 - 4) On the 「Engine Diagnosis」 display screen, select the {OBD System} and press the [YES] key.
 - 5) On the 「OBD Menu」 display screen, select the {O2 Sensor Monitor} and press the [YES] key.
 - 6) On the 「O2 Sensor Select」 display screen, select the {Bank 1-Sensor1} or {Bank 1-Sensor2} and press the [YES] key.
- Bank 1-Sensor1 indicates the front oxygen or A/F sensor, and Bank 1-Sensor2 indicates the rear oxygen sensor.
 - A list of the support data is shown in the following table.

Contents	Display	Unit of measure
Oxygen sensor for monitoring test	<O2 Sensor Monitor (-----)>	—
Rich to lean oxygen sensor threshold voltage	Rich to lean sensor volt	V
Lean to rich oxygen sensor threshold voltage	Lean to rich sensor volt	V
Low oxygen sensor voltage for switch time calculation	Low sensor voltage	V
High oxygen sensor voltage for switch time calculation	High sensor voltage	V
Rich to lean oxygen sensor switch time	Rich to lean switch time	sec
Lean to rich oxygen sensor switch time	Lean to rich switch time	sec
Maximum oxygen sensor voltage for test cycle	Maximum sensor Voltage	V
Minimum oxygen sensor voltage for test cycle	Minimum sensor Voltage	V

NOTE:

For detailed operation procedure, refer to the SUBARU SELECT MONITOR OPERATION MANUAL.

8. LED OPERATION MODE FOR ENGINE

- 1) On the 「Main Menu」 display screen, select the {Each System Check} and press the [YES] key.
 - 2) On the 「System Selection Menu」 display screen, select the {Engine Control System} and press the [YES] key.
 - 3) Press the [YES] key after displayed the information of engine type.
 - 4) On the 「Engine Diagnosis」 display screen, select the {Current Data Display & Save} and press the [YES] key.
 - 5) On the 「Data Display Menu」 display screen, select the {Data & LED Display} and press the [YES] key.
 - 6) Using the scroll key, move the display screen up or down until the desired data is shown.
- A list of the support data is shown in the following table.

Contents	Display	Message	LED "ON" requirements
Ignition switch signal	Ignition Switch	ON or OFF	When ignition switch is turned ON.
Test mode connector signal	Test Mode Signal	ON or OFF	When test mode connector is connected.
Neutral position switch signal	Neutral Position Switch	ON or OFF	When neutral position signal is entered.
Air conditioning switch signal	A/C Switch	ON or OFF	When air conditioning switch is turned ON.
Air conditioning relay signal	A/C Relay	ON or OFF	When air conditioning relay is in function.
Radiator main fan relay signal	Radiator Fan Relay #1	ON or OFF	When radiator main fan relay is in function.
Fuel pump relay signal	Fuel Pump Relay	ON or OFF	When fuel pump relay is in function.
Knocking signal	Knocking Signal	ON or OFF	When knocking signal is entered.
Radiator sub fan relay signal	Radiator Fan Relay #2	ON or OFF	When radiator sub fan relay is in function.
Engine torque control signal #1	Torque Control Signal #1	ON or OFF	When engine torque control signal 1 is entered.
Engine torque control signal #2	Torque Control Signal #2	ON or OFF	When engine torque control signal 2 is entered.
Engine torque control permission signal	Torque Control Permit	ON or OFF	When engine torque control permission signal is entered.
Front oxygen (A/F) sensor rich signal	Front O2 Rich Signal #1	ON or OFF	When front oxygen (A/F) sensor mixture ratio is rich.
Rear oxygen sensor rich signal	Rear O2 Rich Signal	ON or OFF	When rear oxygen sensor mixture ratio is rich.
Pressure control solenoid valve	PCV Solenoid Valve	ON or OFF	When pressure control solenoid valve is in function.
Drain valve	Vent. Solenoid Valve	ON or OFF	When drain valve is in function.
Starter switch signal	Starter Switch Signal	ON or OFF	When starter switch signal is entered.
Idle switch signal	Idle Switch Signal	ON or OFF	When idle switch signal is entered.
Crankshaft position sensor signal	Crankshaft Position Sig.	ON or OFF	When crankshaft position sensor signal is entered.
Camshaft position sensor signal	Camshaft Position Sig.	ON or OFF	When camshaft position sensor signal is entered.

NOTE:

For detailed operation procedure, refer to the SUBARU SELECT MONITOR OPERATION MANUAL.

9. READ CURRENT DATA SHOWN ON DISPLAY FOR AT.

- 1) On the 「Main Menu」 display screen, select the {Each System Check} and press the [YES] key.
 - 2) On the 「System Selection Menu」 display screen, select the {Transmission Control System} and press the [YES] key.
 - 3) Press the [YES] key after displayed the information of transmission type.
 - 4) On the 「Transmission Diagnosis」 display screen, select the {Current Data Display & Save} and press the [YES] key.
 - 5) On the 「Data Display Menu」 display screen, select the {Data Display} and press the [YES] key.
 - 6) Using the scroll key, move the display screen up or down until the desired data is shown.
- A list of the support data is shown in the following table.

Contents	Display	Unit of measure
Battery voltage	Battery Voltage	V
Vehicle speed sensor 1 signal	Vehicle Speed #1	km/h or MPH
Vehicle speed sensor 2 signal	Vehicle Speed #2	km/h or MPH
Engine speed signal	Engine Speed	rpm
Automatic transmission fluid temperature signal	ATF Temp.	°C or °F
Throttle position signal	Throttle Sensor Voltage	V
Gear position	Gear Position	—
Line pressure control duty ratio	Line Pressure Duty Ratio	%
Lock up clutch control duty ratio	Lock Up Duty Ratio	%
Transfer clutch control duty ratio	Transfer Duty Ratio	%
Power supply for throttle position sensor	Throttle Sensor Power	V
Torque converter turbine speed signal	AT Turbine Speed	rpm
2-4 brake timing pressure control duty ratio	2-4B Duty Ratio	%
Intake manifold pressure sensor voltage	Mani. Pressure Voltage	V
2 wheel drive switch signal	2WD Switch	ON or OFF
Kick down switch signal	Kick Down Switch	ON or OFF
Stop lamp switch signal	Stop Lamp Switch	ON or OFF
Anti lock brake system signal	ABS Signal	ON or OFF
Cruise control system signal	Cruise Control Signal	ON or OFF
Neutral/Parking range signal	N/P Range Signal	ON or OFF
Reverse range signal	R Range Signal	ON or OFF
Drive range signal	D Range Signal	ON or OFF
3rd range signal	3rd Range Signal	ON or OFF
2nd range signal	2nd Range Signal	ON or OFF
1st range signal	1st Range Signal	ON or OFF
Shift control solenoid A	Shift Solenoid #1	ON or OFF
Shift control solenoid B	Shift Solenoid #2	ON or OFF
Torque control output signal #1	Torque Control Signal #1	ON or OFF
Torque control output signal #2	Torque Control Signal #2	ON or OFF
Torque control cut signal	Torque Control Cut Sig.	ON or OFF
2-4 brake timing control solenoid valve	2-4 Brake Timing Sol.	ON or OFF
Low clutch timing control solenoid valve	Low Clutch Timing Sol.	ON or OFF
Automatic transmission diagnosis indicator lamp	AT Diagnosis Lamp	ON or OFF

NOTE:

For detailed operation procedure, refer to the SUBARU SELECT MONITOR OPERATION MANUAL.

D: CLEAR MEMORY MODE

1. SUBARU SELECT MONITOR (NORMAL MODE)

- 1) On the 「Main Menu」 display screen, select the {2. Each System Check} and press the [YES] key.
- 2) On the 「System Selection Menu」 display screen, select the {Engine Control System} and press the [YES] key.
- 3) Press the [YES] key after displayed the information of engine type.
- 4) On the 「Engine Diagnosis」 display screen, select the {Clear Memory} and press the [YES] key.
- 5) When the 'Done' and 'Turn Ignition Switch OFF' are shown on the display screen, turn the Subaru Select Monitor and ignition switch to OFF.

NOTE:

- After the memory has been cleared, the ISC must be initialized. To do this, turn the ignition switch to the ON position. Wait 3 seconds before starting the engine. (AT vehicles only)
- For detailed operation procedure, refer to the SUBARU SELECT MONITOR OPERATION MANUAL.

2. SUBARU SELECT MONITOR (OBD MODE)

- 1) On the 「Main Menu」 display screen, select the {2. Each System Check} and press the [YES] key.
- 2) On the 「System Selection Menu」 display screen, select the {Engine Control System} and press the [YES] key.
- 3) Press the [YES] key after displayed the information of engine type.
- 4) On the 「Engine Diagnosis」 display screen, select the {OBD System} and press the [YES] key.
- 5) On the 「OBD Menu」 display screen, select the {4. Diagnosis Code(s) Cleared} and press the [YES] key.
- 6) When the 'Clear Diagnostic Code?' is shown on the display screen, press the [YES] key.
- 7) Turn Subaru Select Monitor and ignition switch to OFF.

NOTE:

- After the memory has been cleared, the ISC must be initialized. To do this, turn the ignition switch to the ON position. Wait 3 seconds before starting the engine. (AT vehicles only)
- For detailed operation procedure, refer to the SUBARU SELECT MONITOR OPERATION MANUAL.

3. OBD-II GENERAL SCAN TOOL

For clear memory procedures using the OBD-II general scan tool, refer to the OBD-II General Scan Tool Instruction Manual.

After the memory has been cleared, the ISC must be initialized. To do this, turn the ignition switch to the ON position. Wait 3 seconds before starting the engine. (AT vehicles only)

E: INSPECTION MODE

1. PREPARATIONS FOR THE INSPECTION MODE

Raise the vehicle using a garage jack and place on safety stands or drive the vehicle onto free rollers.

WARNING:

- Before raising the vehicle, ensure parking brakes are applied.
- Do not use a pantograph jack in place of a safety stand.
- Secure a rope or wire to the front and rear towing or tie-down hooks to prevent the lateral runoff of front wheels.
- Do not abruptly depress/release clutch pedal or accelerator pedal during works even when engine is operating at low speeds since this may cause vehicle to jump off free rollers.
- In order to prevent the vehicle from slipping due to vibration, do not place any wooden blocks or similar items between the safety stands and the vehicle.
- Since the rear wheels will also rotate, do not place anything near them. Also, make sure that nobody goes in front of the vehicle.

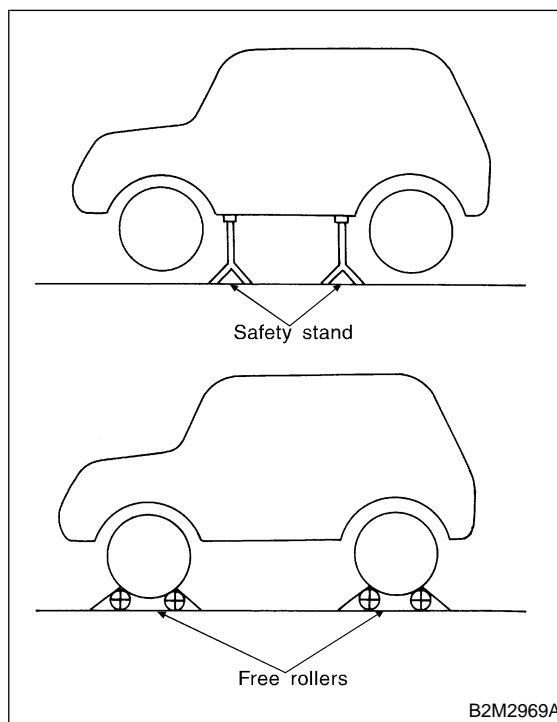

2. SUBARU SELECT MONITOR

After performing diagnostics and clearing the memory, check for any remaining unresolved trouble data.

1) Prepare Subaru Select Monitor kit.

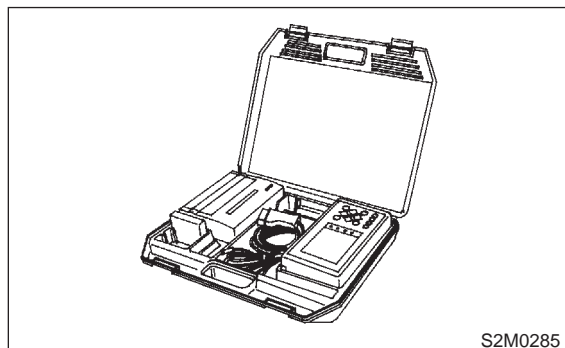

2) Connect diagnosis cable to Subaru Select Monitor.

3) Insert cartridge into Subaru Select Monitor.
<Ref. to 1-6 [G1100].>

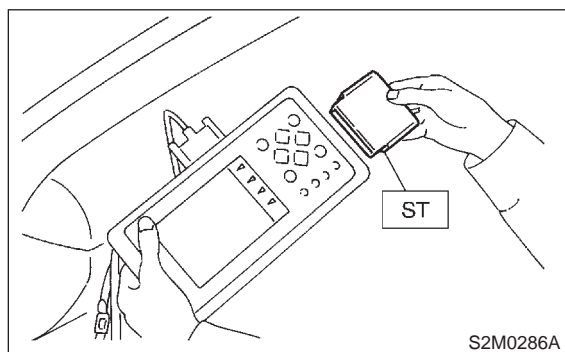

4) Connect test mode connector at the lower portion of instrument panel (on the driver's side), to the side of the center console box.

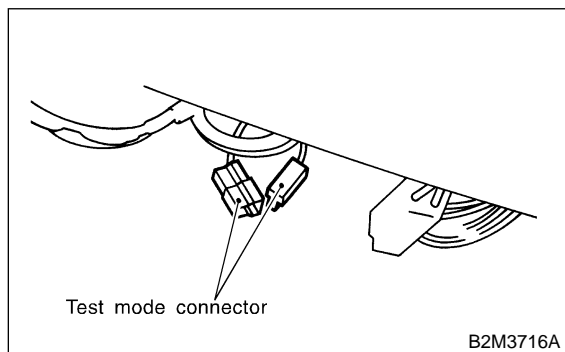

5) Connect Subaru Select Monitor to data link connector.

(1) Connect Subaru Select Monitor to data link connector located in the lower portion of the instrument panel (on the driver's side).

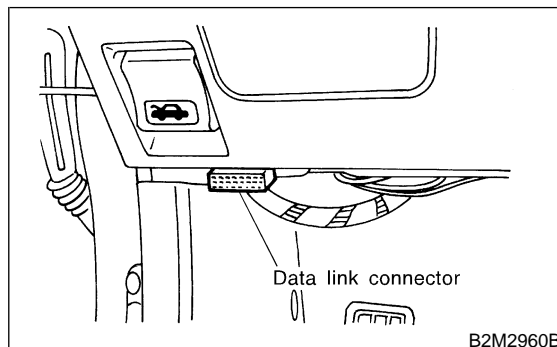

(2) Connect diagnosis cable to data link connector.

CAUTION:

Do not connect scan tools except for Subaru Select Monitor and OBD-II general scan tool.

6) Turn ignition switch to ON (engine OFF) and Subaru Select Monitor switch to ON.

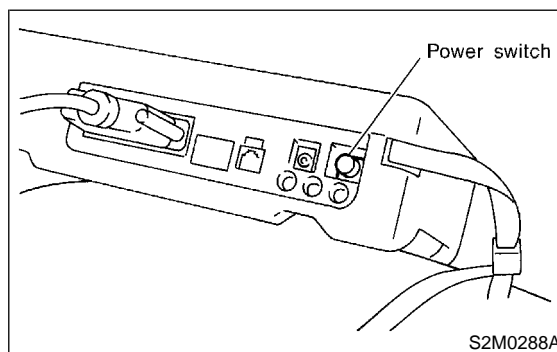

7) On the 「Main Menu」 display screen, select the {2. Each System Check} and press the [YES] key.

8) On the 「System Selection Menu」 display screen, select the {Engine Control System} and press the [YES] key.

9) Press the [YES] key after displayed the information of engine type.

10) On the 「Engine Diagnosis」 display screen, select the {Dealer Check Mode Procedure} and press the [YES] key.

11) When the "Perform Inspection (Dealer Check) Mode?" is shown on the display screen, press the [YES] key.

12) Perform subsequent procedures as instructed on the display screen.

- If trouble still remains in the memory, the corresponding diagnostic trouble code (DTC) appears on the display screen.

NOTE:

- For detailed operation procedure, refer to the SUBARU SELECT MONITOR OPERATION MANUAL.
- For detailed concerning diagnostic trouble codes, refer to the DIAGNOSTIC TROUBLE CODE (DTC) LIST.
 - MT vehicles: <Ref. to 2-7 [T10A0].>
 - AT vehicles: <Ref. to 2-7 [T11A0].>
- Release the parking brake.
- The speed difference between front and rear wheels may light either the ABS warning light, but this indicates no malfunctions. When engine control diagnosis is finished, perform the ABS memory clearance procedure of self-diagnosis system.

3. OBD-II GENERAL SCAN TOOL

After performing diagnostics and clearing the memory, check for any remaining unresolved trouble data:

- 1) Connect test mode connector at the lower side of the instrument panel (on the driver's side), to the side of the center console box.

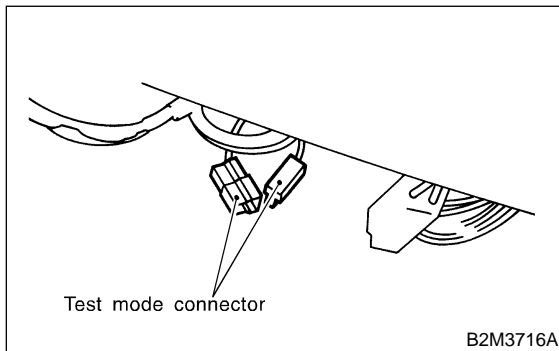

- 2) Connect the OBD-II general scan tool to its data link connector in the lower portion of the instrument panel (on the driver's side).

CAUTION:

Do not connect the scan tools except for Subaru Select Monitor and OBD-II general scan tool.

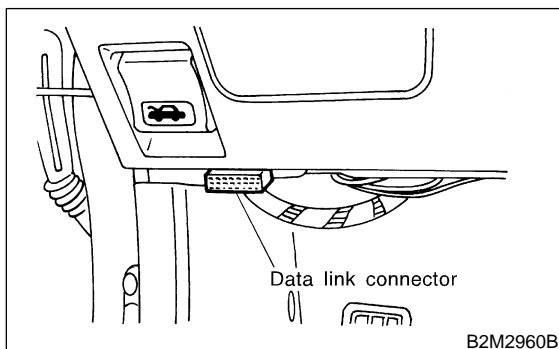

- 3) Start the engine.

NOTE:

- Ensure the selector lever is placed in the "P" position before starting. (AT vehicles)
 - Depress clutch pedal when starting the engine. (MT vehicles)
- 4) Using the selector lever or shift lever, turn the "P" position switch and the "N" position switch to ON.
 - 5) Depress the brake pedal to turn the brake switch ON. (AT vehicles)
 - 6) Keep engine speed in the 2,500 — 3,000 rpm range for 40 seconds.

NOTE:

On models without tachometer, use the tachometer (Secondary pickup type).

- 7) Place the selector lever or shift lever in the "D" position (AT vehicles) or "1st" gear (MT vehicles) and drive the vehicle at 5 to 10 km/h (3 to 6 MPH).

NOTE:

- On AWD vehicles, release the parking brake.
- The speed difference between front and rear wheels may light the ABS warning light, but this indicates no malfunctions. When engine control diagnosis is finished, perform the ABS memory clearance procedure of self-diagnosis system.

- 8) Using the OBD-II general scan tool, check for diagnostic trouble code(s) and record the result(s).

NOTE:

- For detailed operation procedures, refer to the OBD-II General Scan Tool Instruction Manual.
- For detailed concerning diagnostic trouble codes, refer to the DIAGNOSTIC TROUBLE CODE (DTC) LIST.
 - MT vehicles: <Ref. to 2-7 [T10A0].>
 - AT vehicles: <Ref. to 2-7 [T11A0].>

F: COMPULSORY VALVE OPERATION CHECK MODE**1. SUBARU SELECT MONITOR**

- 1) Prepare Subaru Select Monitor kit.

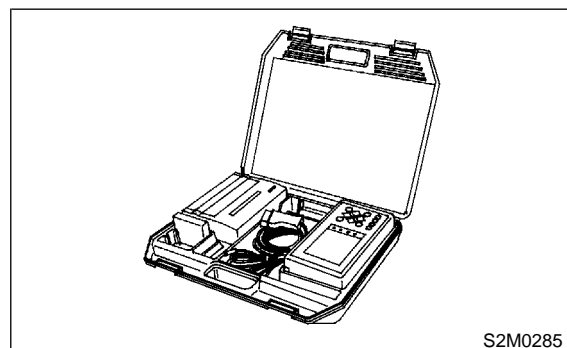

- 2) Connect diagnosis cable to Subaru Select Monitor.

3) Insert cartridge into Subaru Select Monitor.
<Ref. to 1-6 [G1100].>

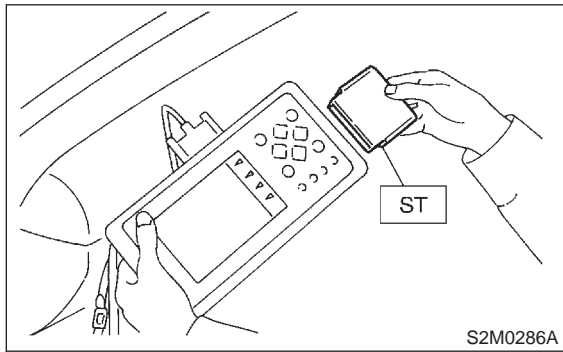

4) Connect test mode connector at the lower portion of instrument panel (on the driver's side), to the side of the center console box.

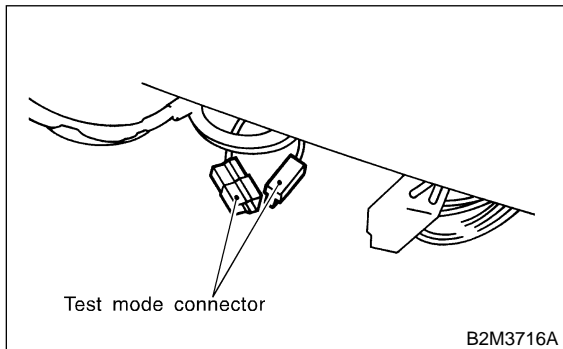

5) Connect Subaru Select Monitor to data link connector.

(1) Connect Subaru Select Monitor to data link connector located in the lower portion of the instrument panel (on the driver's side).

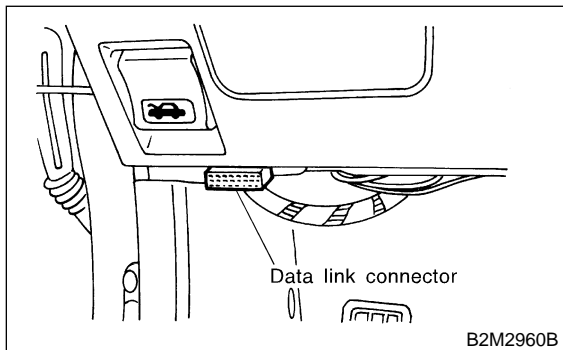

(2) Connect diagnosis cable to data link connector.

CAUTION:

Do not connect scan tools except for Subaru Select Monitor and OBD-II general scan tool.

6) Turn ignition switch to ON (engine OFF) and Subaru Select Monitor switch to ON.

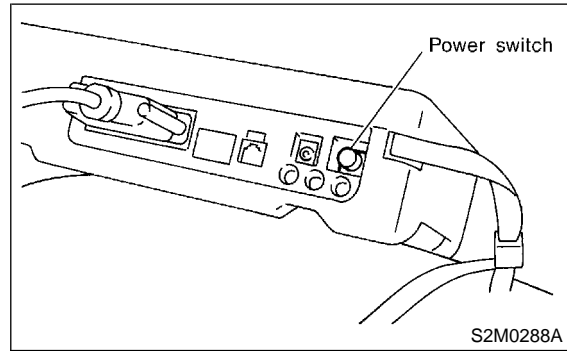

7) On the 「Main Menu」 display screen, select the {2. Each System Check} and press the [YES] key.
8) On the 「System Selection Menu」 display screen, select the {Engine Control System} and press the [YES] key.

9) Press the [YES] key after displayed the information of engine type.

10) On the 「Engine Diagnosis」 display screen, select the {System Operation Check Mode} and press the [YES] key.

11) On the 「System Operation Check Mode」 display screen, select the {Actuator ON/OFF Operation} and press the [YES] key.

12) Select the desired compulsory actuator on the 「Actuator ON/OFF Operation」 display screen and press the [YES] key.

13) Pressing the [NO] key completes the compulsory operation check mode. The display will then return to the 「Actuator ON/OFF Operation」 screen.

- A list of the support data is shown in the following table.

Contents	Display
Compulsory fuel pump relay operation check	Fuel Pump Relay
Compulsory radiator fan relay operation check	Radiator Fan Relay
Compulsory air conditioning relay operation check	A/C Relay
Compulsory pressure control solenoid valve operation check	PCV Solenoid Valve
Compulsory drain valve operation check	Vent Control Solenoid Valve

NOTE:

- Because ASV solenoid valve, FICD solenoid valve and air injection system diagnosis solenoid valve are not installed, ASV Solenoid Valve, FICD Solenoid Valve and Pressure Switching Sol.2 will be displayed but non-functional.
- For detailed operation procedure, refer to the SUBARU SELECT MONITOR OPERATION MANUAL.