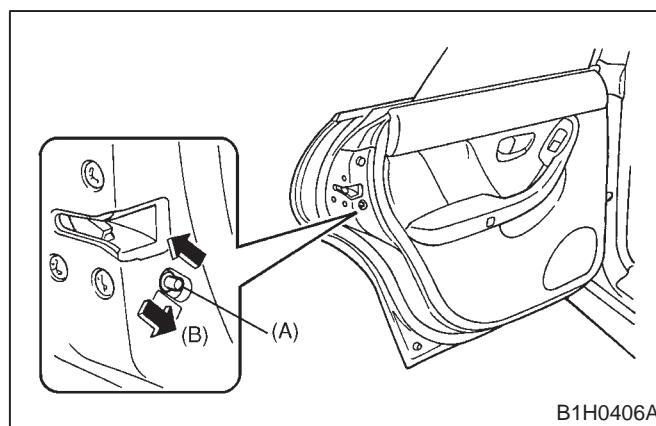
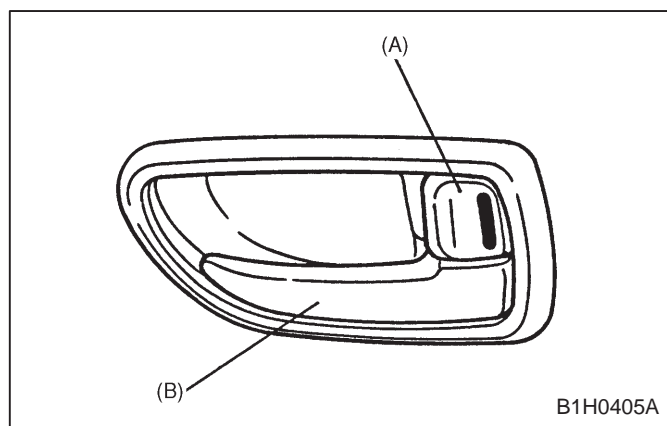

1-4 [G2C3]**2. Pre-road Test Inspection****PRE-DELIVERY INSPECTION****3. CHECK THE LOOSENESS OF DOORS**

- 1) Open and close the door two or three times with a somewhat strong force.
- 2) Check the bolts or screws securing the door hinge, lock and striker for looseness. Retighten loose ones to the specified tightening torque.

4. CHECK THE OPERATION OF POWER WINDOW

- 1) Depress the power window switches to fully open the windows.
- 2) Pull up the power window switches to fully close the windows.
- 3) Repeat the above steps beginning with the first one, two or three times to see how the windows open and close.

5. CHECK THE OPERATION OF POWER DOOR LOCK

- 1) Close the door completely.
- 2) Operate the door lock switches on the front both side doors to lock and check that all the doors are locked.
- 3) Operate the door lock switches on the front both side doors to unlock and check that all the doors are unlocked.
- 4) Repeat the above steps two or three times.

6. CHECK THE OPERATION OF CHILD SAFETY LOCKS

- 1) Set the child safety lock (A) on both rear doors to the lock positions (B).

- 2) Close the rear doors completely.
- 3) Check that the lock levers of the rear doors are in the unlock positions. Then, pull the inside door handles of the rear doors to ensure that the doors will not open.
- 4) Next, pull the outside door handles of the rear doors to ensure that the doors will open.
- 5) Repeat the above steps two or three times.

D: TRUNK LID, REAR GATE AND FUEL LID OPERATION**CHECK POINTS**

1. Trunk lid, rear gate and fuel lid "open-close" operation
2. Operation of trunk lid and rear gate (release and lock)
3. Fitting of trunk lid, rear gate and fuel lid
4. Operation of trunk lid opener cancel lever

E: SEAT ADJUSTER AND SEAT BELTS**CHECK POINTS**

1. Front and rear seats, and their facing materials
2. Front seat operation
3. Rear seat folding operation
4. Seat belts and their fit

1. MANUAL THREE-POINT TYPE

The seat belt warning light on the combination meter comes on for approximately six seconds with the ignition switch "ON".

And the warning chime sounds if the driver's seat belt is not fastened.

Make sure that the warning system works normally.