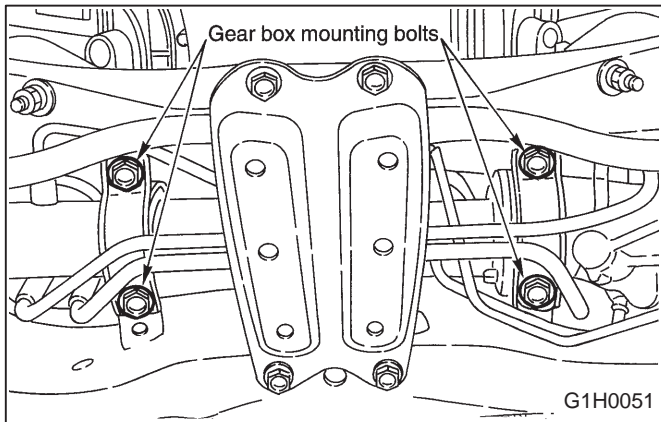

**1-4 [G2H2]****2. Pre-road Test Inspection****PRE-DELIVERY INSPECTION****2. CHECK THE GEAR BOX MOUNTING BOLT FOR LOOSENESS****NOTE:**

Carefully check the root portion of the boots, and the condition of the clips.

**Tightening torque:**

$59 \pm 12 \text{ N.m}$  ( $6 \pm 1.2 \text{ kg-m}$ ,  $43 \pm 9 \text{ ft-lb}$ )

**3. CHECK THE TIE-ROD END LOCK NUT FOR LOOSENESS****Tightening torque:**

$83 \pm 5 \text{ N.m}$  ( $8.5 \pm 0.5 \text{ kg-m}$ ,  $61 \pm 3.6 \text{ ft-lb}$ )

**I: WHEEL ALIGNMENT****CHECK POINTS**

1. *Toe of front and rear wheels*
2. *Camber of front wheels*

Before checking the toe and camber, make sure that the spare tire and service tools are on the vehicle and the fuel tank is full, but no other weight is on the vehicle.

**J: EXHAUST PIPE AND MUFFLER****CHECK POINTS**

1. *Installation of exhaust system*
2. *Exhaust gas leakage from parts or joints*

Check the exhaust system's installation for looseness, damage and possible interference with other parts. <Ref. to 2-9 [C100].>

**WARNING:**

**When the engine is running, and for a short time after it is stopped, the exhaust system remains very hot; use extreme care and don't get burnt during this evolution.**

**K: FUEL SYSTEM FOR LEAKAGE****CHECK POINTS**

1. *Installation of fuel injector, hose and pipe. And condition of clamps*
2. *Fuel system for leakage*

**1. CHECK THE INSTALLATION OF FUEL INJECTOR, HOSE AND PIPE, AND THE CONDITION OF CLAMPS****WARNING:**

**When checking the fuel system, use extreme care to prevent accidental fires.**

**NOTE:**

When retightening the clamps, do not tighten them excessively.

- 1) Check the fuel hose's layout, and also search for interference with other parts, twists, or damage, check the condition of the clamps.
- 2) Check the fuel and air breather pipes visually or by feeling with your fingers from the underside. Retighten the clamps if necessary.
- 3) Check the installation of fuel injector.

**2. CHECK THE FUEL SYSTEM FOR LEAKAGE**

Without starting the engine, turn the ignition switch to the ON position, and operate the fuel pump to pressurize the fuel system. Then check the fuel system for leakage.