

1-4 [G4A0]**4. Post-road Test Inspection****PRE-DELIVERY INSPECTION****4. Post-road Test Inspection****A: AUTOMATIC TRANSMISSION FLUID (ATF) LEVEL****CHECK POINT****1. Level of ATF****CAUTION:**

Do not fill above the high mark level.

NOTE:

If the fluid level is at the lower mark or below on the "HOT" side, add the recommended ATF to bring the level to the high mark. ATF is added through the level gauge hole. When the fluid level has to be checked without time to warm up the AT, check to see that the fluid level is within the marks on the "COLD" side. If it is below the marks, add fluid.

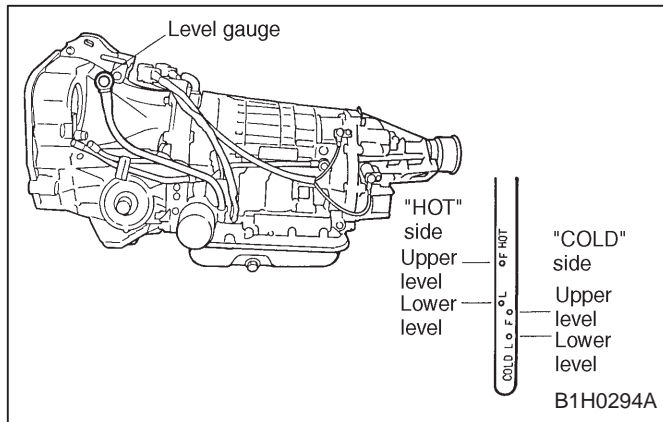

The ATF should be maintained at the proper level as follows:

- 1) Drive the vehicle several miles to bring the transmission to the normal operating temperature. 60 to 80°C (140 to 176°F) is normal.
- 2) Park the vehicle on a level surface.
- 3) While idling the engine, move selector lever to all ranges. Then return to the P range.
- 4) Remove the level gauge and wipe it clean.
- 5) Reinsert the level gauge completely.
- 6) Remove it again and note its reading.

Recommended automatic transmission fluid

DEXRON II, IIE or III

B: POWER STEERING FLUID LEVEL**CHECK POINT****1. Level of power steering fluid**

The power steering fluid should be maintained at a proper level.

CAUTION:

The available power steering fluid is DEXRON II, IIE or III type automatic transmission fluid.

Be sure to use the recommended fluid.

When power steering fluid is added, be careful not to allow any dust into the tank.

Check level as follows:

- 1) Check to ensure that the temperature of the reservoir tank surface is approximately 20°C (68°F).
- 2) Park the vehicle on a level surface and stop the engine.
- 3) Check the fluid level using the scale on the outside of the reservoir tank (A). If the level is below "MIN" (B), add fluid to bring it up to "MAX" (C). If at upper level or above, drain fluid by using a syringe or the like.

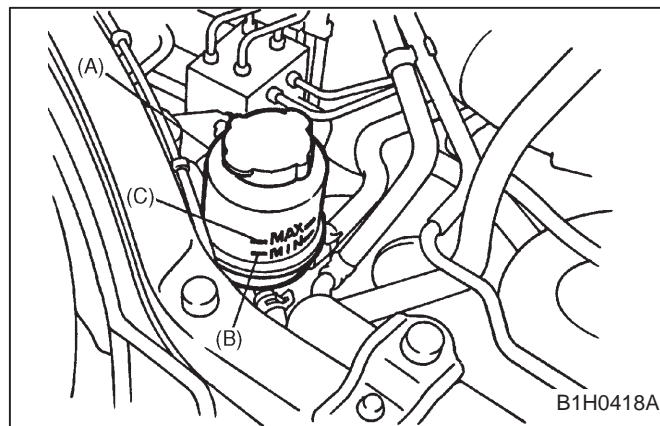
**C: UNDERSIDE****CHECK POINTS**

1. Leakage of engine oil, transmission gear oil, differential gear oil, etc.
2. Leakage of coolant
3. Leakage of brake fluid
4. Loose suspension mountings or steering mounting

Raise the vehicle body and perform these checks from the underside.