

4. Master Cylinder

A: LHD MODEL

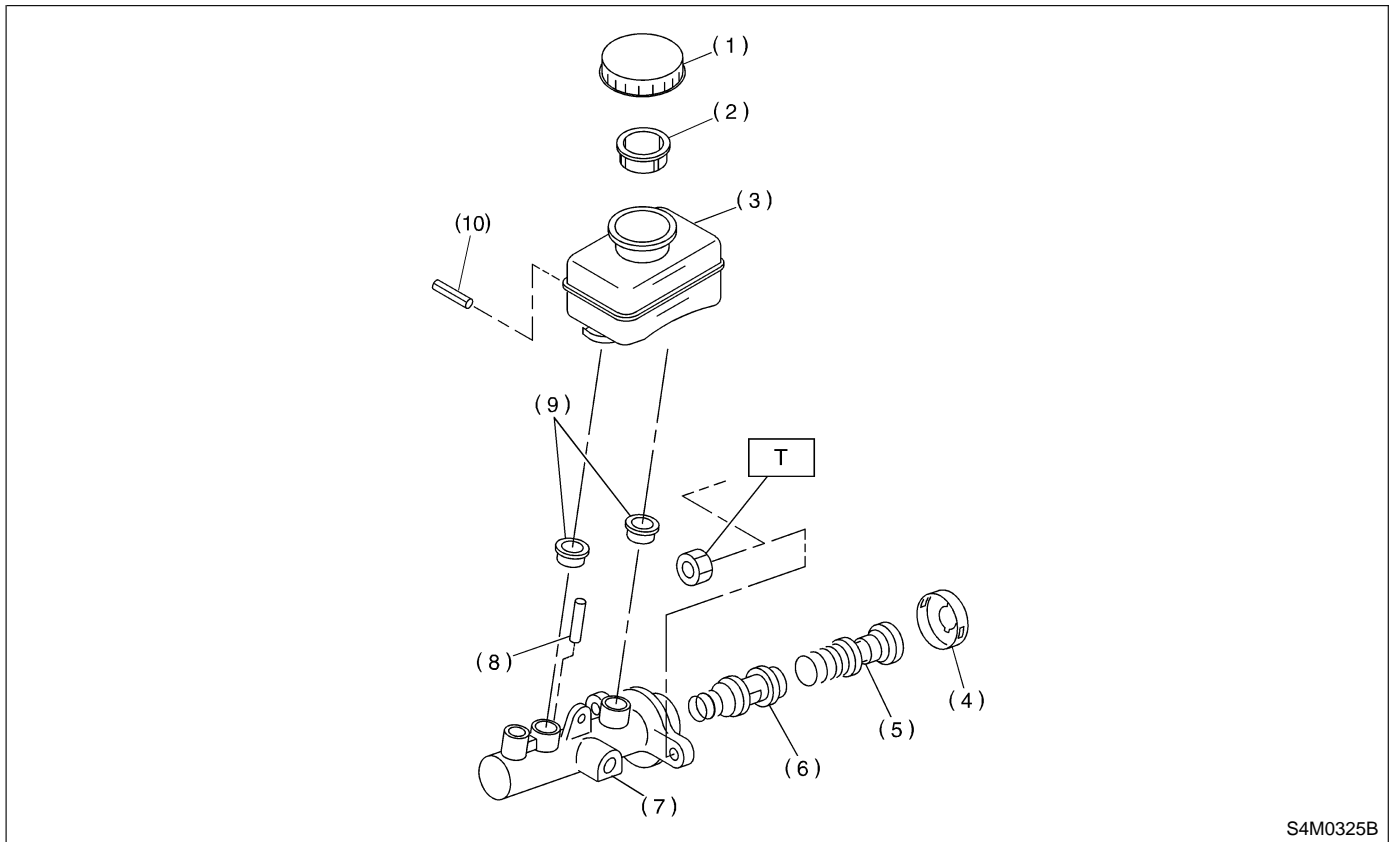

S4M0325B

- | | |
|---------------------|-----------------------------|
| (1) Cap | (6) Secondary piston |
| (2) Filter | (7) Cylinder body |
| (3) Reservoir tank | (8) Cylinder pin (With ABS) |
| (4) Piston retainer | (9) Seal |
| (5) Primary piston | (10) Pin |

Tightening torque: N·m (kg·m, ft·lb)

T: 14±4 (1.4±0.4, 10.1±2.9)

B: RHD MODEL

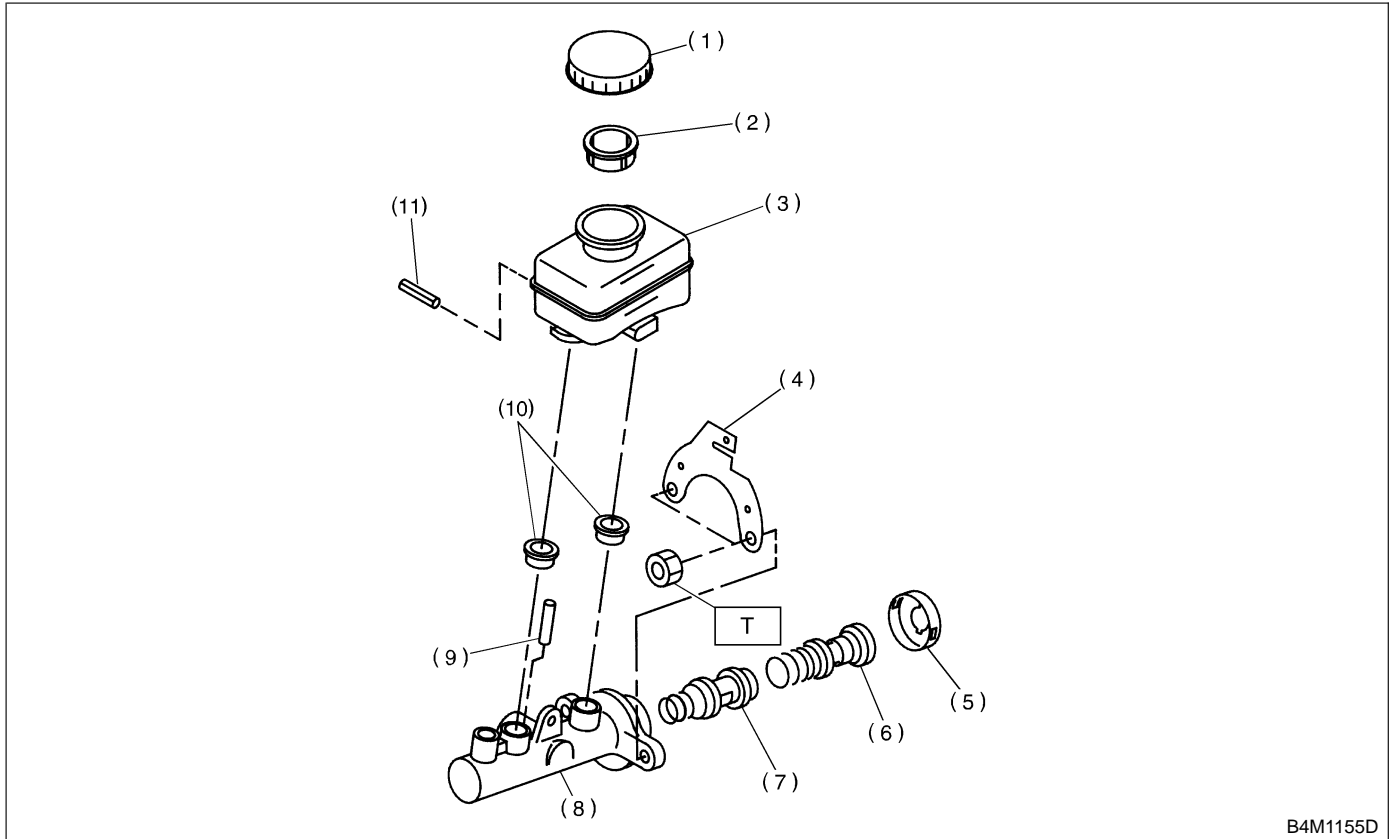

B4M1155D

- | | |
|---------------------|-----------------------------|
| (1) Cap | (6) Primary piston |
| (2) Filter | (7) Secondary piston |
| (3) Reservoir tank | (8) Cylinder body |
| (4) Bracket | (9) Cylinder pin (With ABS) |
| (5) Piston retainer | (10) Seal |

- (11) Pin

Tightening torque: N·m (kg·m, ft·lb)

T: 14±4 (1.4±0.4, 10.1±2.9)