

4. Control Valve (Power Steering Gearbox)

A: CHECKING OIL LEAKING POINTS

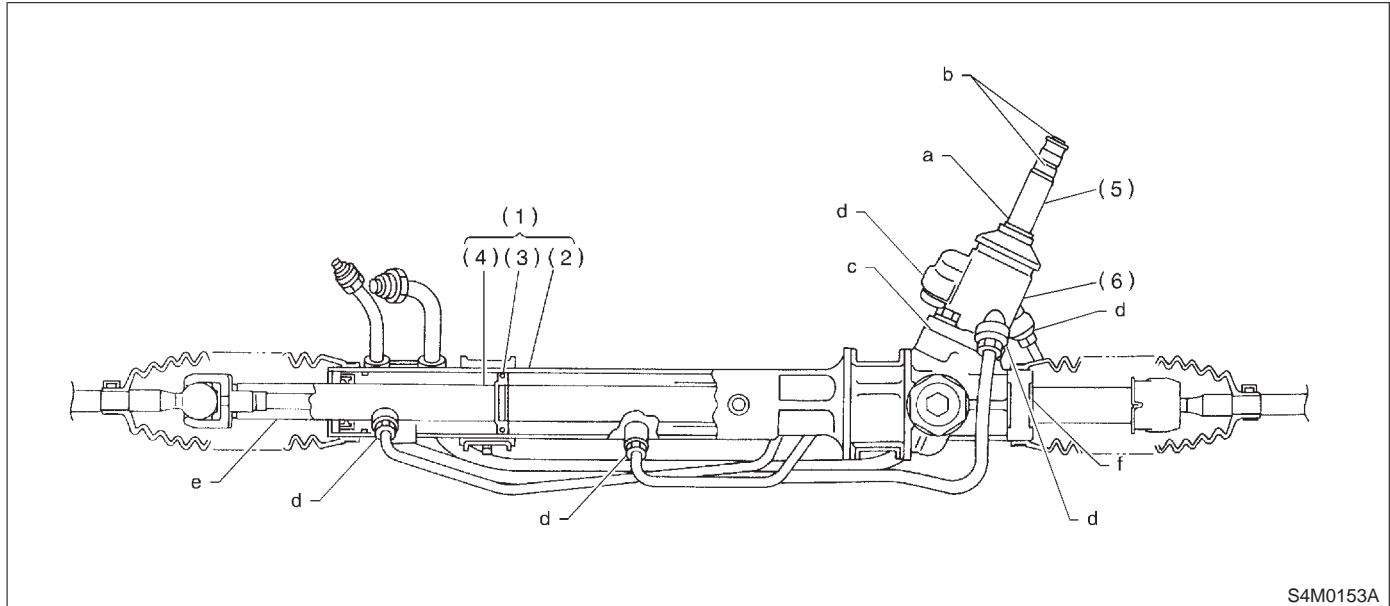

- | | | |
|--------------------|-----------------|-------------------|
| (1) Power cylinder | (3) Rack piston | (5) Input shaft |
| (2) Cylinder | (4) Rack axle | (6) Valve housing |

1. OIL LEAKING POINTS

1) If leak point is other than a, b, c, or d, perform the 5th step in "OIL LEAK CHECK PROCEDURE AND REPLACEMENT PARTS" before dismounting gearbox from vehicle. <Ref. to 4-3 [W4A2].> If gearbox is dismounted without confirming where the leak is, it must be mounted again to locate the leak point.

2) Even if the location of the leak can be easily found by observing the leaking condition, it is necessary to thoroughly remove the oil from the suspected portion and turn the steering wheel from lock to lock about 30 to 40 times with engine running, then make comparison of the suspected portion between immediately after and several hours after this operation.

3) Before starting oil leak repair work, be sure to clean the gearbox, hoses, pipes, and surrounding parts. After completing repair work, clean these areas again.

2. OIL LEAK CHECK PROCEDURE AND REPLACEMENT PARTS

NOTE:

Parts requiring replacement are described in the smallest unit of spare parts including damaged parts and spare parts damaged. In actual disassembly work, accidental damage as well as inevitable damage to some related parts must be taken into account, and spare parts for them must also be prepared. However, it is essential to pinpoint the cause of trouble, and limit the number of replacement parts as much as possible.

1) Leakage from "a"

The oil seal is damaged. Replace valve assembly with a new one.

2) Leakage from "b"

The torsion bar O-ring is damaged. Replace valve assembly with a new one.

3) Leakage from "c"

The oil seal is damaged. Replace valve assembly or oil seal with a new one.

4) Leakage from "d"

The pipe is damaged. Replace the faulty pipe or O-ring.

5) If leak is other than a, b, c, or d, and if oil is leaking from the gearbox, move the right and left boots toward tie-rod end side, respectively, with the gearbox mounted to the vehicle, and remove oil from the surrounding portions. Then, turn the steering wheel from lock to lock 30 to 40 times with the engine running, then make comparison of the leaked portion immediately after and several hours after this operation.

(1) Leakage from "e"

The cylinder seal is damaged. Replace rack bush with a new one.

(2) Leakage from "f"

There are two possible causes. Take following step first. Remove the pipe assembly B from the valve housing, and close the circuit with ST.

ST 926420000 PLUG

Turn the steering wheel from lock to lock 30 to 40 times with the engine running, then make comparison of the leaked portion between immediately after and several hours after this operation.

CAUTION:

● If leakage from "f" is noted again:

The oil seal of pinion and valve assembly is damaged. Replace pinion and valve assembly with a new one. Or replace the oil seal and the parts that are damaged during disassembly with new ones.

● If oil stops leaking from "f":

The oil seal of rack housing is damaged. Replace the oil seal and the parts that are damaged during disassembly with new ones.

B: DISASSEMBLY

NOTE:

This section focuses on the disassembly and reassembly of control valve. For the inspection and adjustment and the service procedures for associated parts, refer to "Steering Gearbox". <Ref. to 4-3 [W3A0].>

1. VALVE ASSEMBLY

1) Remove two bolts securing valve assembly.

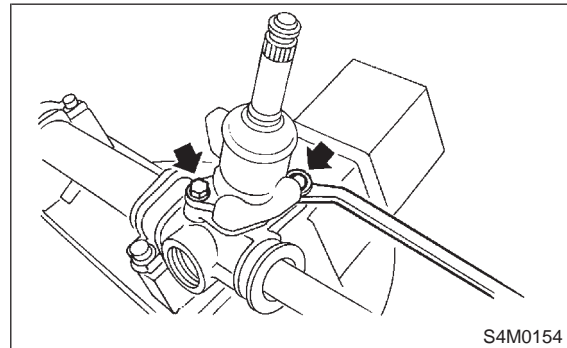

2) Carefully draw out input shaft and remove valve assembly.

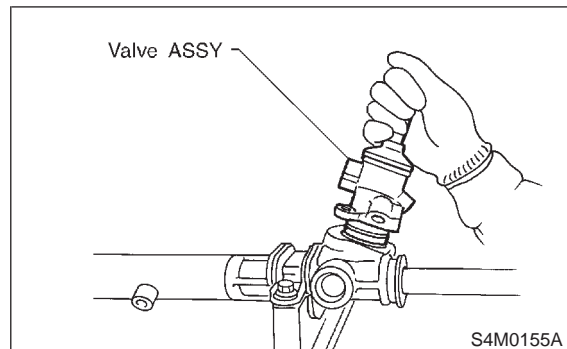

3) Draw out pinion and valve assembly from valve housing, as necessary, using pipe of I.D. 44 to 46 mm (1.73 to 1.81 in) and a press.

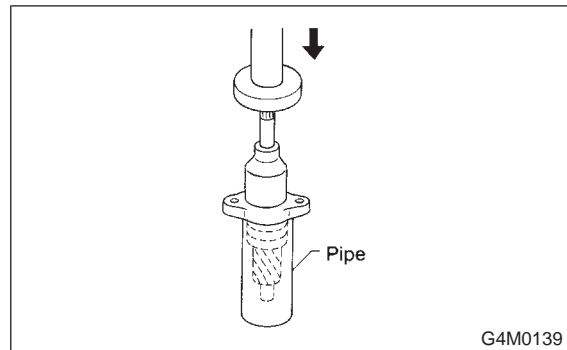

2. RACK ASSEMBLY

1) Using a sharp pointed pliers, rotate the rack stopper in the direction of the arrow until the end of the circlip comes out of the stopper. Rotate the circlip in the opposite direction and pull it out.

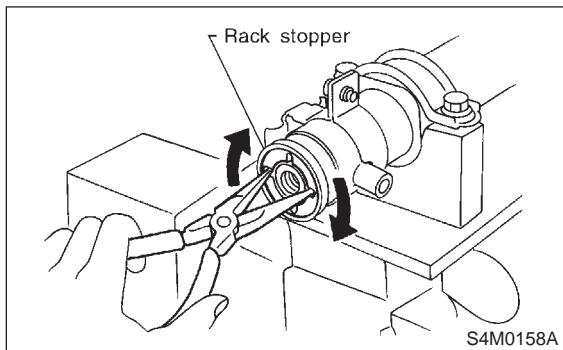

2) Pull rack assembly from cylinder side, and draw out rack bushing and rack stopper together with rack assembly.

CAUTION:

Be careful not to contact rack to inner wall of cylinder when drawing out. Any scratch on cylinder inner wall will cause oil leakage.

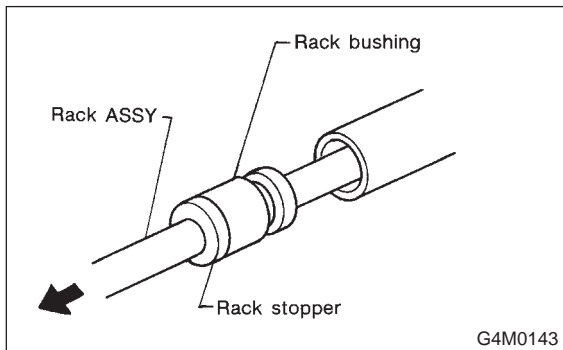

3) Remove rack bushing and rack stopper from rack assembly.

CAUTION:

Do not reuse removed rack bushing and circlip.

C: REPLACEMENT OF SEAL AND PACKING

1. VALVE HOUSING OIL SEAL

Specified steering grease:

VALIANT GREASE M2 (Part No. 003608001)

- 1) Pry off dust seal using screwdriver.
- 2) Remove snap ring using snap ring pliers.

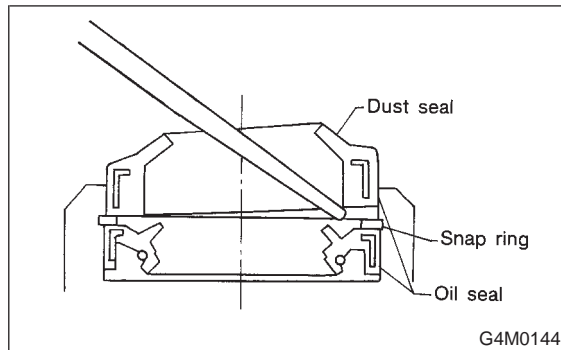

- 3) Pry off oil seal using screwdriver.

CAUTION:

After removing, check inside surface of valve housing for damage. If oil seal contacting surface is damaged, replace valve housing with a new one.

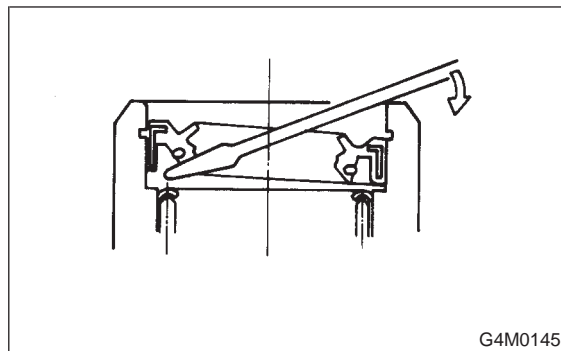

4) Press-fit oil seal into valve housing using ST and press.

ST 927610000 INSTALLER

NOTE:

Before fitting, coat oil seal fully with ATF DEXRON IIE or ATF DEXRON III.

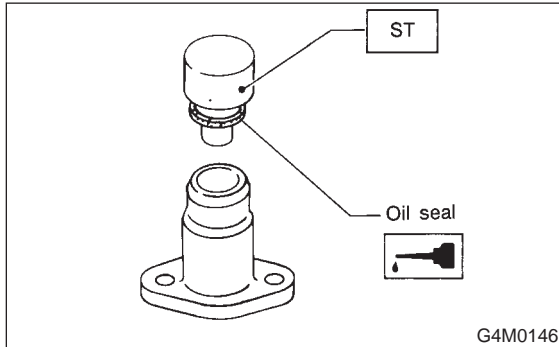

5) Fit snap ring in snap ring groove using snap ring pliers.

CAUTION:

Be careful not to scratch oil seal with snap ring pliers.

NOTE:

Rotate snap ring to check for proper installation.

2. PINION AND VALVE ASSEMBLY

1) Remove snap ring using snap ring pliers.

CAUTION:

- Do not reuse removed snap ring.
- Be careful not to scratch pinion and valve assembly.

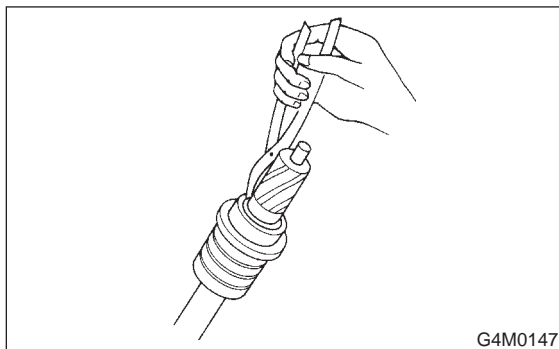

2) Press out bearing together with backing washer using pipe of I.D. 38.5 to 39.5 mm (1.516 to 1.555 in) and press.

CAUTION:

Do not reuse removed bearing.

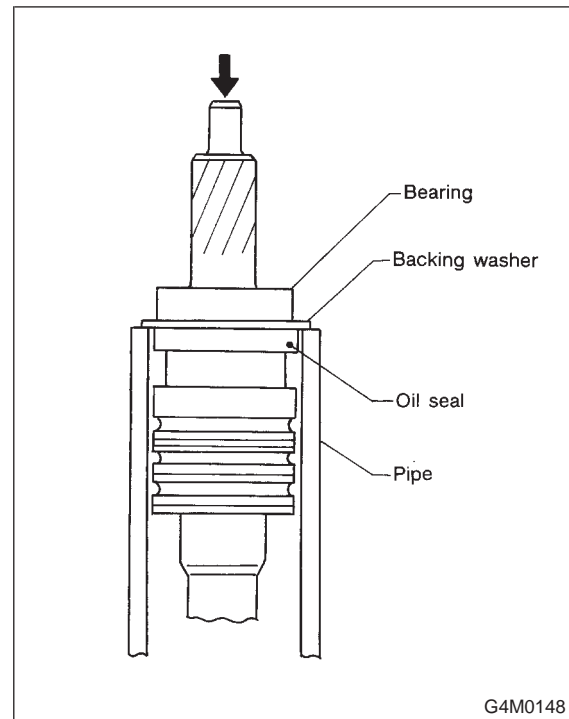

3) Remove oil seal.

CAUTION:

Do not reuse removed oil seal.

4) Put vinyl tape around pinion shaft splines to protect oil seal from damage.

5) Fit pinion and valve assembly into valve housing.

NOTE:

Apply specified power steering fluid to outer diameter surface of input shaft and outer surface of valve body seal ring, and pay special attention not to damage seal when inserting pinion and valve assembly.

4. Control Valve (Power Steering Gearbox)

- 6) Secure valve assembly to ST1 and ST2.
- 7) Put ST3 over pinion, and insert oil seal, then force-fit oil seal into housing using ST4.

ST1 926370000 INSTALLER A
 ST2 927630000 STAND BASE
 ST3 926360000 INSTALLER A
 ST4 927620000 INSTALLER B

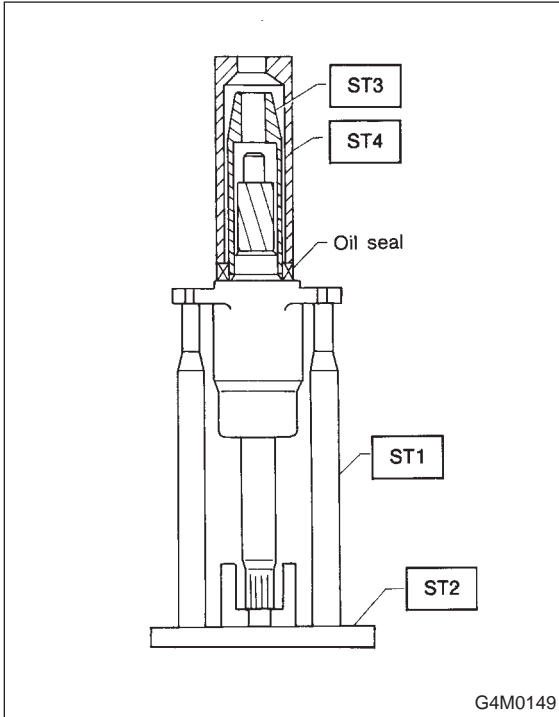

NOTE:

- Apply specified power steering fluid to oil seal and ST3, being careful not to damage oil seal lip.
- Push oil seal until ST3 contacts housing end face.

- 8) Remove ST3, and fit backing washer.
- 9) Force-fit ball bearing using ST3.

ST1 926370000 INSTALLER A
 ST2 927630000 STAND BASE
 ST3 927640000 INSTALLER B

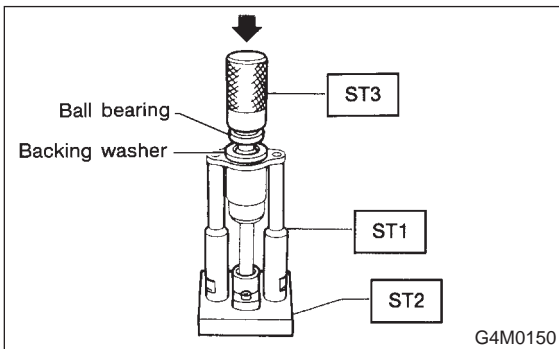

NOTE:

Be careful not to tilt ball bearing during installation.

- 10) Install snap ring using snap ring pliers.

NOTE:

Rotate snap ring to check for proper installation.

3. RACK HOUSING OIL SEAL

- 1) Insert ST from pinion housing side and remove oil seal using a press.

ST 34199AE050 REMOVER OIL SEAL

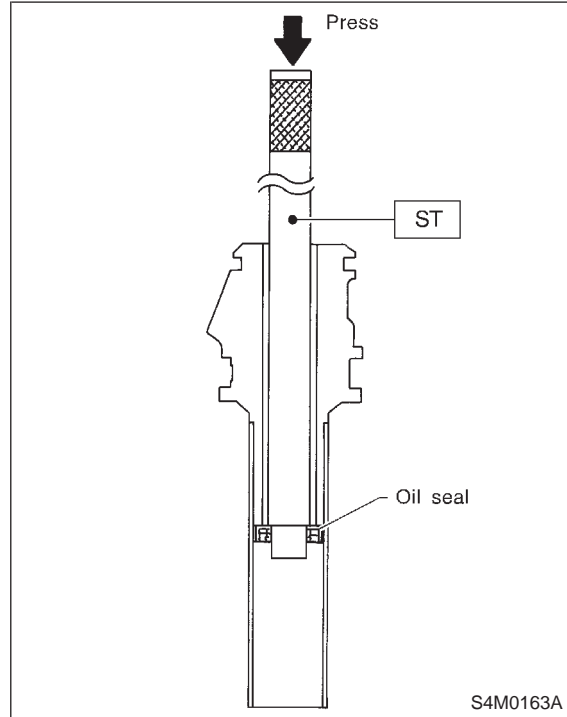

NOTE:

Discard removed oil seal.

2) Force-fit oil seal using ST.
ST 34199AE060 INSTALLER

CAUTION:

Be careful not to damage or scratch cylinder inner wall.

NOTE:

- Apply specified power steering fluid to oil seal.
- Pay special attention not to install oil seal in wrong direction.
- Push oil seal until the stepped portion of A contacts end face of B.

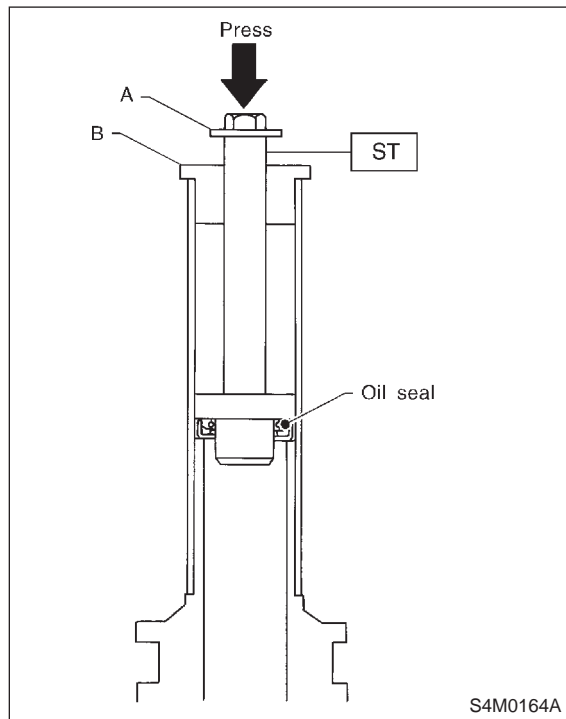
**D: ASSEMBLY****1. RACK ASSEMBLY****CAUTION:**

Use only SUBARU genuine grease for gearbox.

Specified grease for gearbox:

VALIANT GREASE M2 (Part No. 003608001)

- 1) Fixing rack housing
Fix rack housing in vice using ST.
ST 926200000 STAND

CAUTION:

- When fixing rack housing in vice, be sure to use this special tool. Do not fix rack housing in vice using pad such as aluminum plates, etc.
- When using old rack housing, be sure to clean and remove rust before assembling. Check pinion housing bushing carefully.

- 2) Fit ST over toothed portion of rack assembly, and check for binding or unsmooth insertion. If any deformation is noted on flats at the end of rack, shape by using file, and wash with cleaning fluid.
ST 926390001 COVER & REMOVER

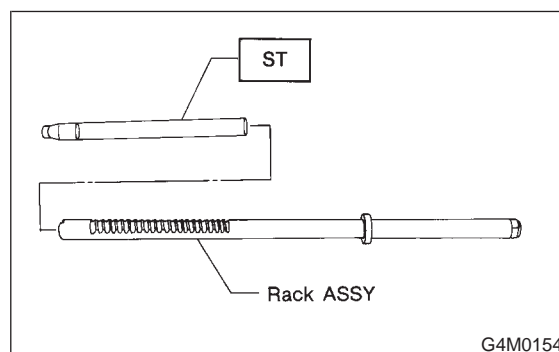

- 3) Apply genuine grease to teeth of thoroughly washed rack assembly, and fit ST over the toothed portion.

CAUTION:

- Be careful not to block air passage with grease. Remove excessive grease.
- After fitting cover, check air passage hole for clogging. If clogged, open by removing grease from the hole.
- Check rack shaft for damage.
- Apply specified power steering fluid to this ST and surface of piston ring to prevent seal from being damaged.

4. Control Valve (Power Steering Gearbox)

4) Insert rack assembly into rack housing from cylinder side, and remove ST after it has passed completely through oil seal.

NOTE:

Before inserting rack assembly, apply a coat of specified power steering fluid to surfaces of ST and rack piston.

ST 926390001 COVER & REMOVER

5) Fit ST1 and ST2 over the end of rack, and install rack bushing.

ST1 926400000 GUIDE

ST2 927660000 GUIDE

CAUTION:

- If burrs, or nicks are found on this guide and rack shaft portion, remove by filing.
- Dip rack bushing in specified power steering fluid before installing, and pay attention not to damage O-ring and oil seal.

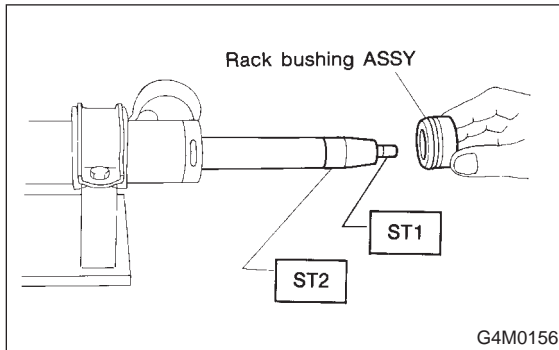

6) Insert rack stopper into cylinder tube until internal groove (on cylinder side) is aligned with external groove (on rack stopper). Turn rack stopper with ST so that rack stopper hole is seen through cylinder slits.

7) Insert rack stopper into rack housing, and wrap circlip using a sharp pointed pliers to secure rack stopper in position.

CAUTION:

Be careful not to scratch rack while winding circlip.

NOTE:

Rotate wrench another 90 to 180° after the end of circlip has been wrapped in.

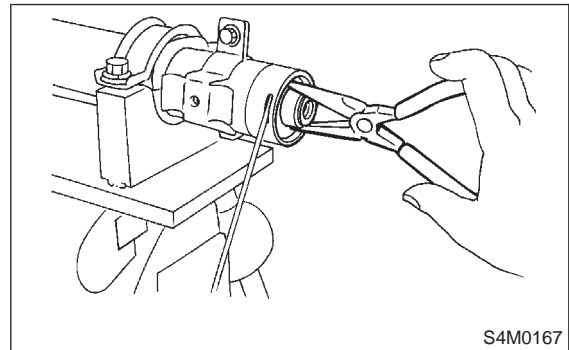

8) Fit mounting rubber onto rack housing.

2. VALVE ASSEMBLY**CAUTION:**

Use only SUBARU genuine grease for gearbox.

Specified grease for gearbox:

VALIANT GREASE M2 (Part No. 003608001)

1) Apply genuine grease to pinion gear and bearing of valve assembly.

