

## 7. Evaporative Emission Control System

### A: GENERAL

- The evaporative emission control system is employed to prevent evaporative fuel from being discharged into ambient atmosphere. This system includes a canister, purge control solenoid valve, fuel cut valve, their connecting lines, etc.
- Gasoline vapor evaporated from the fuel in the fuel tank is introduced into the canister through the evaporation line, and is absorbed on activated carbon in it. A fuel cut valve is also incorporated on the fuel tank line.
- The purge control solenoid valve is controlled by the ECM and provides optimal purge control according to the engine condition.
- A pressure control solenoid valve incorporated in the fuel tank evaporation line controls the pressure/vacuum in the fuel tank according to the pressure/vacuum sensed by the fuel tank pressure sensor.

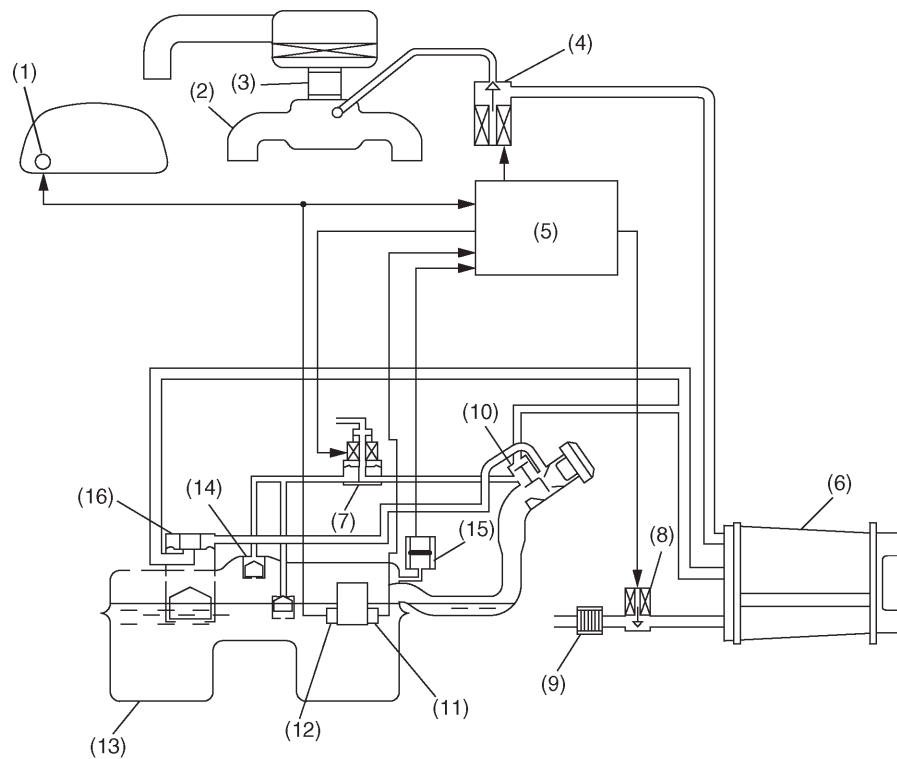

B2H3422A

- |                                  |                                     |                                |
|----------------------------------|-------------------------------------|--------------------------------|
| (1) Fuel gauge                   | (7) Pressure control solenoid valve | (13) Fuel tank                 |
| (2) Intake manifold              | (8) Drain valve                     | (14) Fuel cut valve            |
| (3) Throttle body                | (9) Drain filter                    | (15) Fuel tank pressure sensor |
| (4) Purge control solenoid valve | (10) Shut valve                     | (16) Vent valve                |
| (5) Engine control module (ECM)  | (11) Fuel temperature sensor        |                                |
| (6) Canister                     | (12) Fuel level sensor              |                                |

**2-1 [M7B0]****MECHANISM AND FUNCTION****7. Evaporative Emission Control System****B: FUEL CUT VALVE**

The fuel cut valve is built onto the evaporation pipe of the fuel tank cap. The rising level of the fuel from the fuel tank causes the float to move up and close the cap hole so that no fuel can enter during evaporation line.

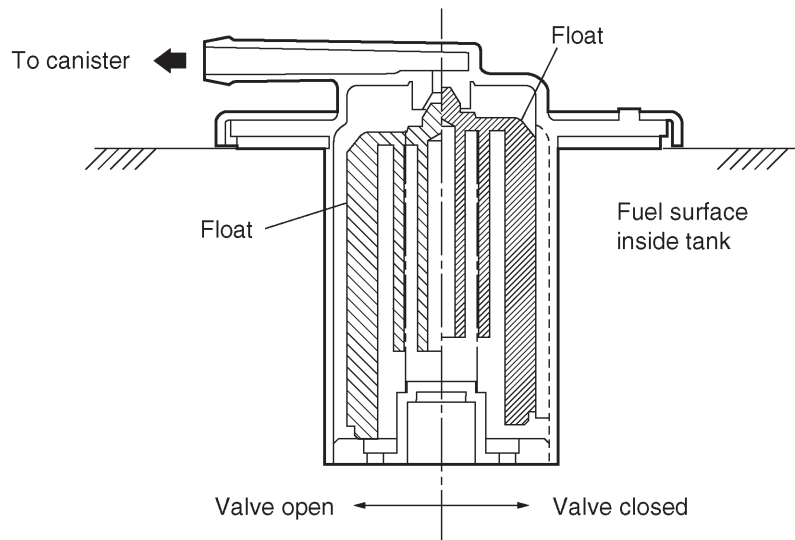

B2H3342A

**C: FUEL CAP**

The relief valve is adopted to prevent the development of vacuum in the fuel tank which may occur in case of trouble in the fuel vapor line.

In normal condition, the filler pipe is sealed at (A) and at the packing pressed against the filler pipe end. As vacuum develops in the fuel tank, atmospheric pressure forces the spring down to open the valve; consequently air is led into the fuel tank controlling the inside pressure.

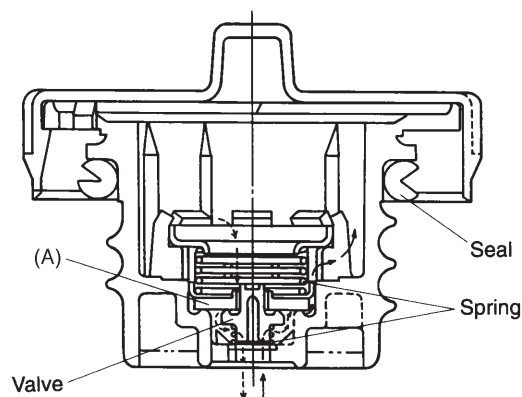

B2H0395A

**MECHANISM AND FUNCTION****[M7E0] 2-1****7. Evaporative Emission Control System****D: CANISTER**

The canister temporarily stores the evaporation gas. When the purge control solenoid valve is opened from a signal sent from the ECM, the evaporation gas is sent into the collector chamber after being mixed with fresh external air.

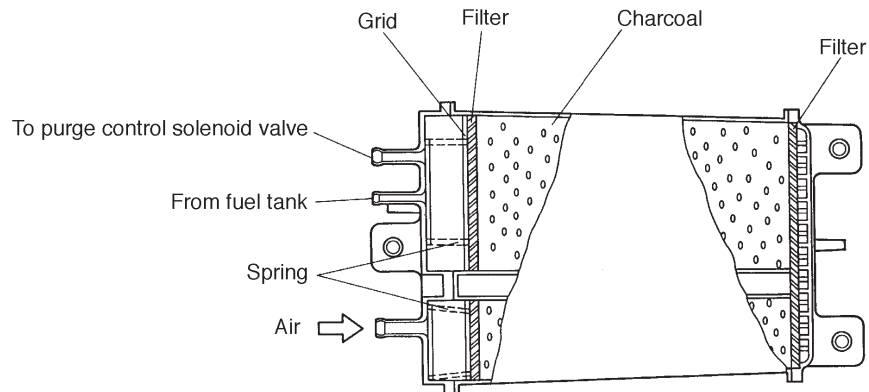

H2H1164B

**E: PURGE CONTROL SOLENOID VALVE**

The purge control solenoid valve is on the evaporation line between canister and throttle body. It is installed at the under side of intake manifold.

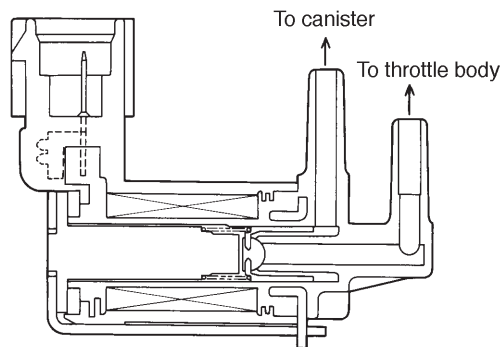

B2H0426

**2-1 [M7F0]****MECHANISM AND FUNCTION****7. Evaporative Emission Control System****F: PRESSURE CONTROL SOLENOID VALVE**

The fuel tank pressure control solenoid valve located in the evaporation line between the shut valve on fuel filler pipe and the canister adjusts the pressure inside the fuel tank under the control of ECM.

When the tank internal pressure is increased and becomes greater than atmospheric pressure, the valve is opened to introduce evaporation gas into the canister to purge.

On the other hand, when the tank internal pressure becomes smaller than atmospheric pressure, external air is taken from the drain valve into the canister.

Also, the pressure control solenoid valve can be electrically closed for system diagnosis.

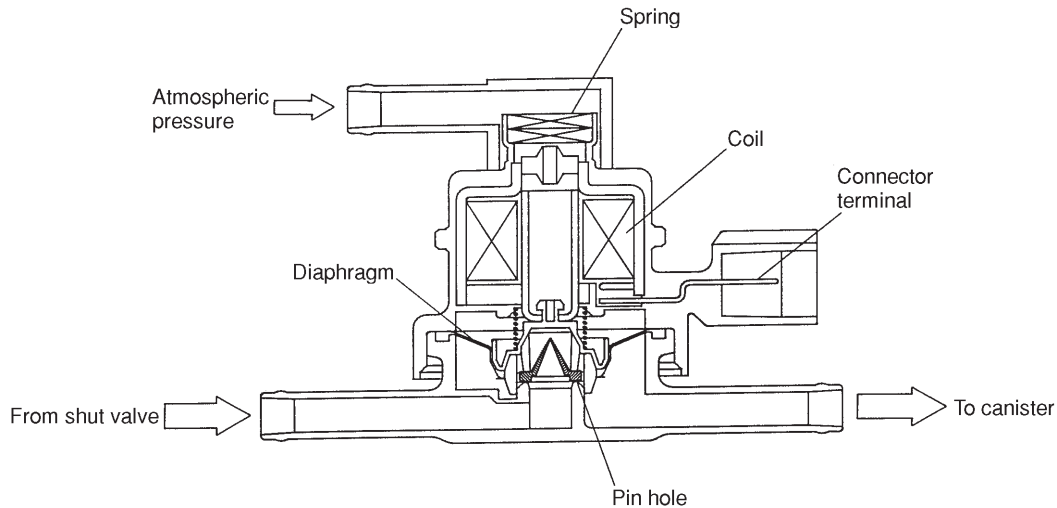

B2H1719A

**G: DRAIN FILTER**

The drain filter is installed at the air inlet port of the vent control solenoid valve to clean the air taken in the canister through the vent control solenoid valve.

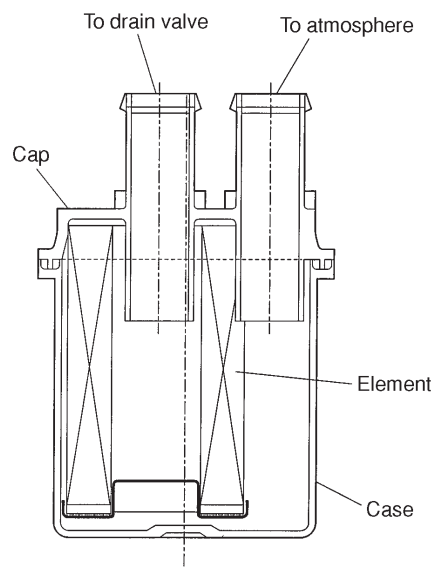

S2H0874

**MECHANISM AND FUNCTION****[M710] 2-1**  
7. Evaporative Emission Control System**H: VENT VALVE**

Vent valve is located on the fuel tank. During filling the fuel tank, evaporation gas is introduced to the canister through vent valve.

When the evaporation pressure overcomes atmospheric pressure and spring force which are applied to the back side of the diaphragm, the port is opened. Also, the float in the vent valve is to stop the fuel which is supplied when the tank is filled up. Increasing fuel level raises the float to close the port.

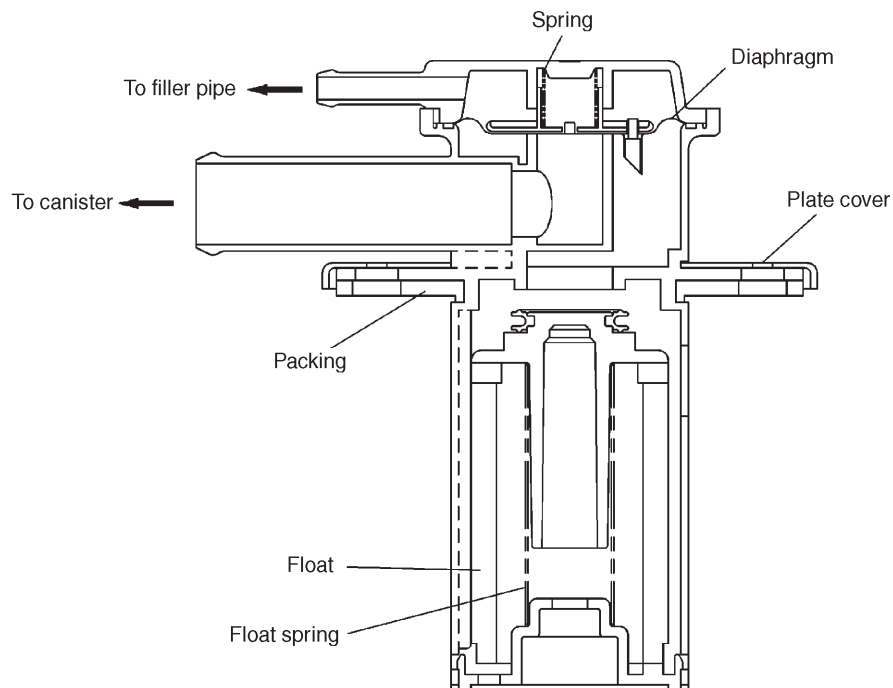

B2H3424A

**I: SHUT VALVE**

Shut valve is located on the upper side of fuel filler pipe. When a filler gun is inserted into the filler pipe, the shut valve closes the evaporation line.

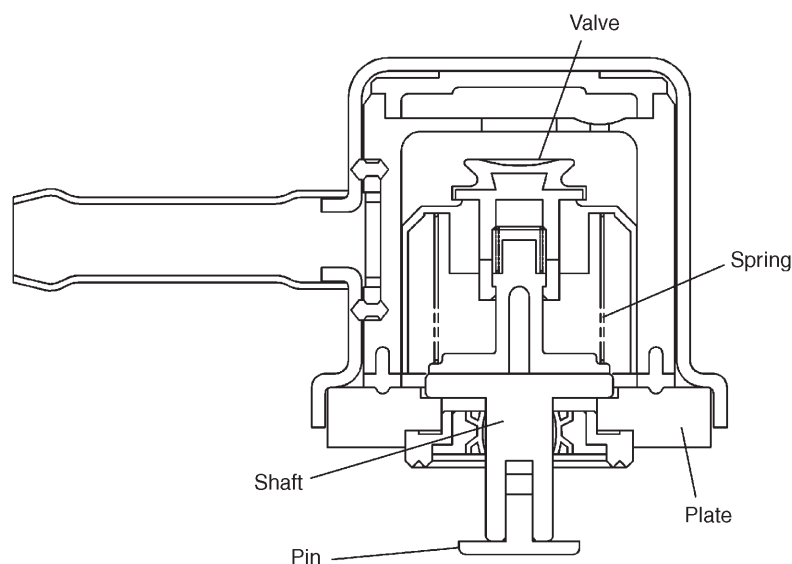

B2H3423A

**2-1 [M7J0]****MECHANISM AND FUNCTION****7. Evaporative Emission Control System**

---

**J: DRAIN VALVE**

The drain valve is located on the line connecting the drain filter and canister, at a point just below the drain filter. The drain valve is forcibly closed by a signal from the ECM while the evaporation system diagnosis is being conducted.

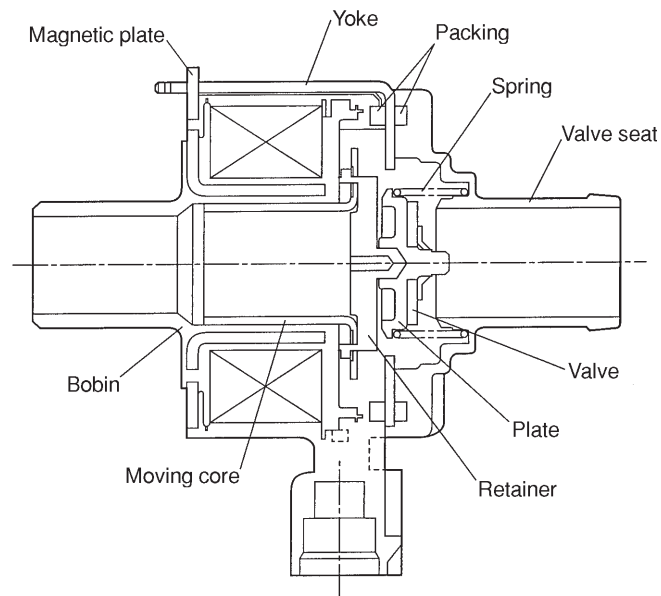

B2H1770