

2. Rear Seat**A: OPERATION****SEDAN**

Provided with a center trunk through and arm rest.

**WAGON**

Provided with a foldable seat.

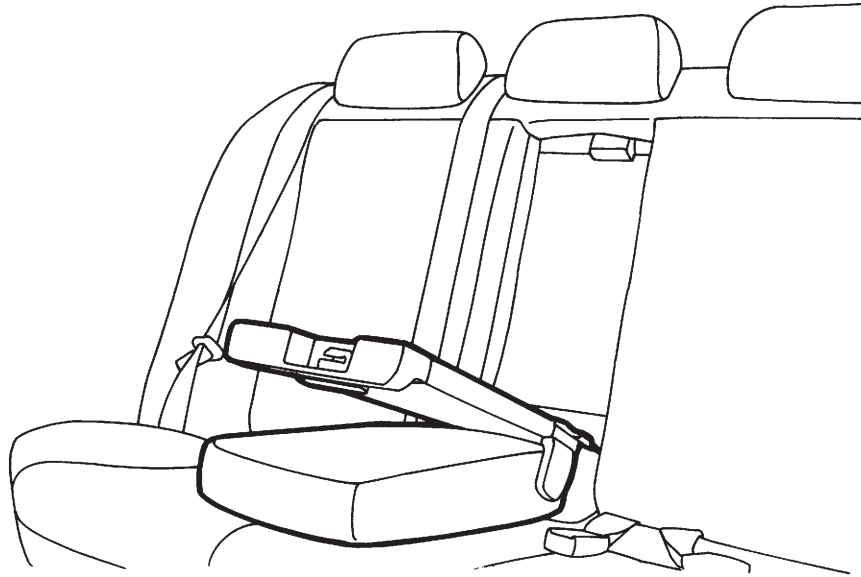
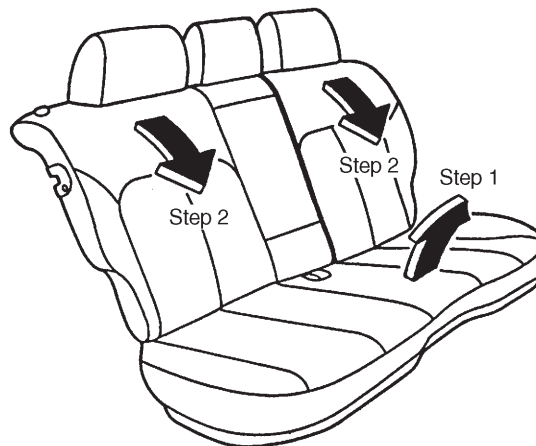

B5H0826A

5-3 [M2B0] 2. Rear Seat

MECHANISM AND FUNCTION

B: BUILT-IN CHILD RESTRAINT

Built-in child restraint is designed for use only by children who weigh between 9.05 kg (20 lb.) and 18.09 kg (40 lb.), whose height is 1100 mm (44.3 in) or less, who are capable of sitting upright alone and whose shoulder height is less than the shoulder belt slot.

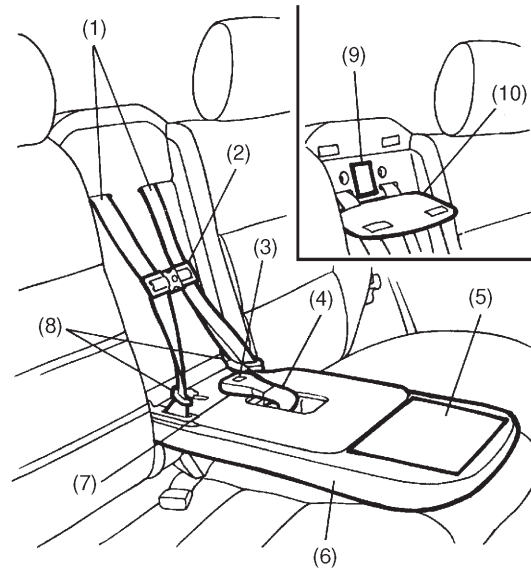

B5H0827A

- (1) Lap-shoulder belt
- (2) Chest clip
- (3) Release button
- (4) Crotch belt
- (5) Warning label
- (6) Child restraint cushion
- (7) Belt buckle
- (8) Tongue plates
- (9) Maximum shoulder height indicator label
- (10) Removable pad