

### 3. Transmission Case and Control Device

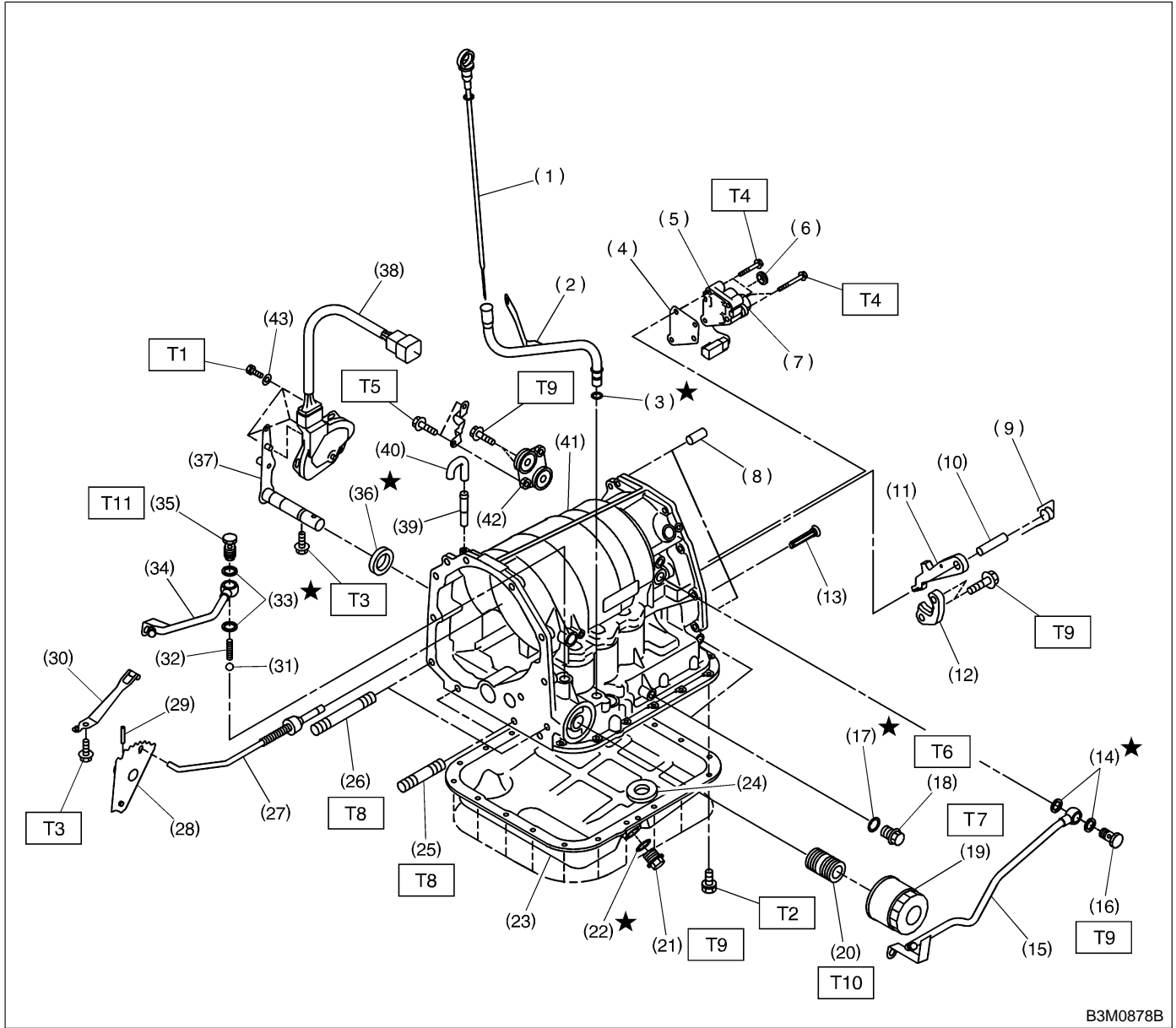

- (1) Oil level gauge
- (2) Oil charger pipe
- (3) O-ring
- (4) Transfer valve plate
- (5) Transfer valve ASSY
- (6) Transfer clutch seal
- (7) Duty solenoid C (Transfer)
- (8) Straight pin
- (9) Return spring
- (10) Shaft
- (11) Parking pawl
- (12) Parking support
- (13) Inlet filter
- (14) Gasket
- (15) Inlet pipe
- (16) Union screw
- (17) O-ring
- (18) Test plug
- (19) Oil filter
- (20) Oil filter stud bolt
- (21) Drain plug
- (22) Gasket
- (23) Oil pan
- (24) Magnet
- (25) Stud bolt (Short)
- (26) Stud bolt (Long)
- (27) Parking rod
- (28) Manual plate
- (29) Spring pin
- (30) Detention spring
- (31) Ball
- (32) Spring
- (33) Gasket
- (34) Outlet pipe
- (35) Union screw
- (36) Oil seal
- (37) Select lever
- (38) Inhibitor switch ASSY

- (39) Nipple
- (40) Air breather hose
- (41) Transmission case
- (42) Plate ASSY
- (43) Washer

**Tightening torque: N-m (kg-m, ft-lb)**

**T1: 3.4±0.5 (0.35±0.05, 2.5±0.4)**

**T2: 4.9±0.5 (0.50±0.05, 3.6±0.4)**

**T3: 5.9±1.0 (0.60±0.10, 4.3±0.7)**

**T4: 7.8±1.0 (0.80±0.10, 5.8±0.7)**

**T5: 12±3 (1.2±0.3, 8.7±2.2)**

**T6: 12.7±1.0 (1.30±0.10, 9.4±0.7)**

**T7: 13.7±2.0 (1.4±0.2, 10.1±1.4)**

**T8: 17.7±2.9 (1.80±0.30, 13.0±2.2)**

**T9: 24.5±2.0 (2.50±0.20, 18.1±1.4)**

**T10: 24.5±2.9 (2.5±0.3, 18.1±2.2)**

**T11: 44±4 (4.5±0.4, 32.5±2.9)**