

1. Transmission Case

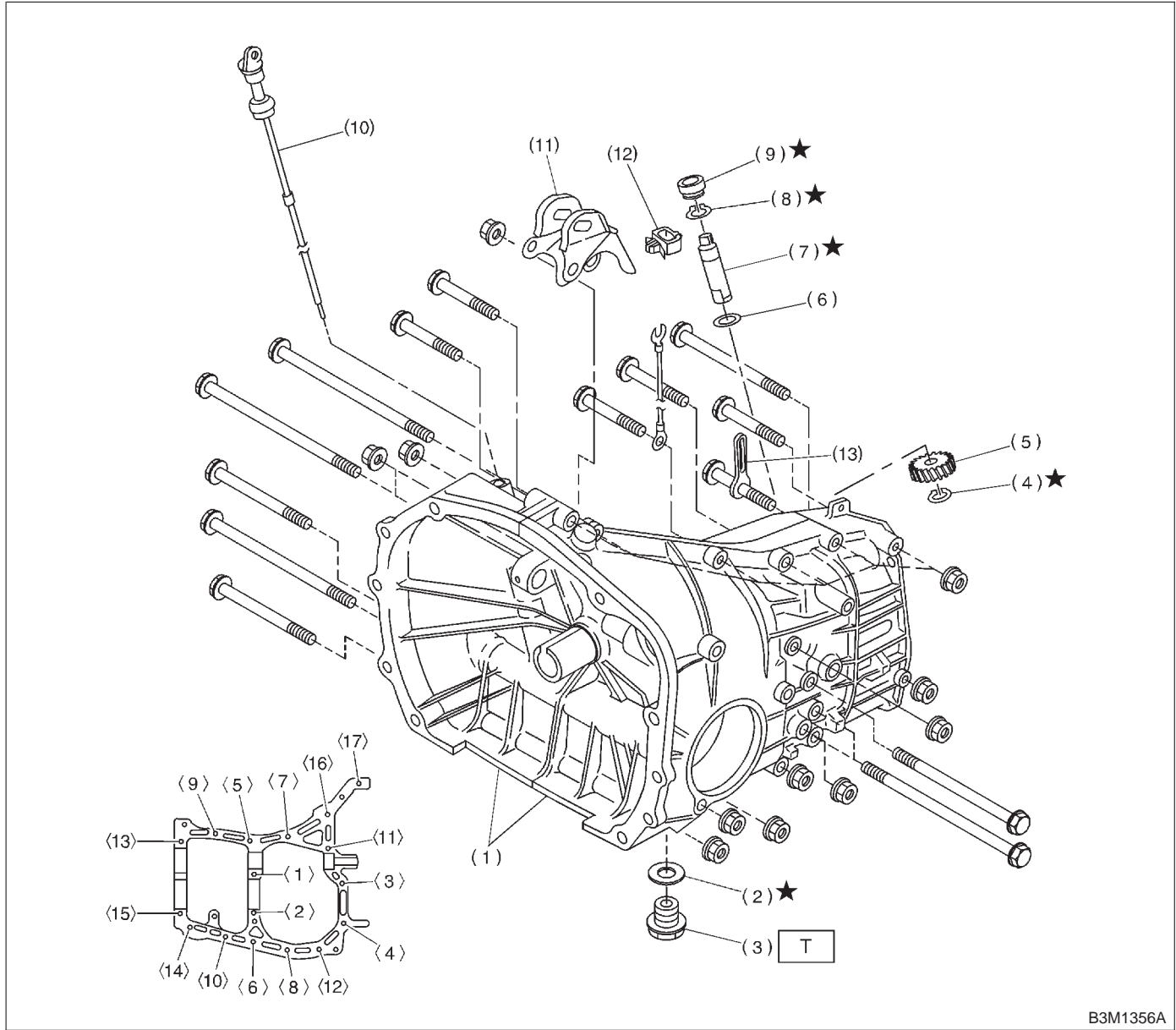

B3M1356A

- (1) Transmission case ASSY
- (2) Gasket
- (3) Drain plug
- (4) Snap ring (Outer)
- (5) Speedometer driven gear
- (6) Washer
- (7) Speedometer shaft
- (8) Snap ring (Outer)
- (9) Oil seal
- (10) Oil level gauge
- (11) Pitching stopper bracket
- (12) Clamp

(13) Clip

Tightening torque: N·m (kg·m, ft·lb)

T: 44±3 (4.5±0.3, 32.5±2.2)

Size	All models	Torque
8 mm bolt	<5> — <15>	25±2 N·m (2.5±0.2 kg·m, 18.1±1.4 ft·lb)
10 mm bolt	<1> — <4> <16> — <17>	39±3 N·m (4.0±0.3 kg·m, 28.9±2.2 ft·lb)