

6. Wiring Diagram

A: POWER SUPPLY ROUTING

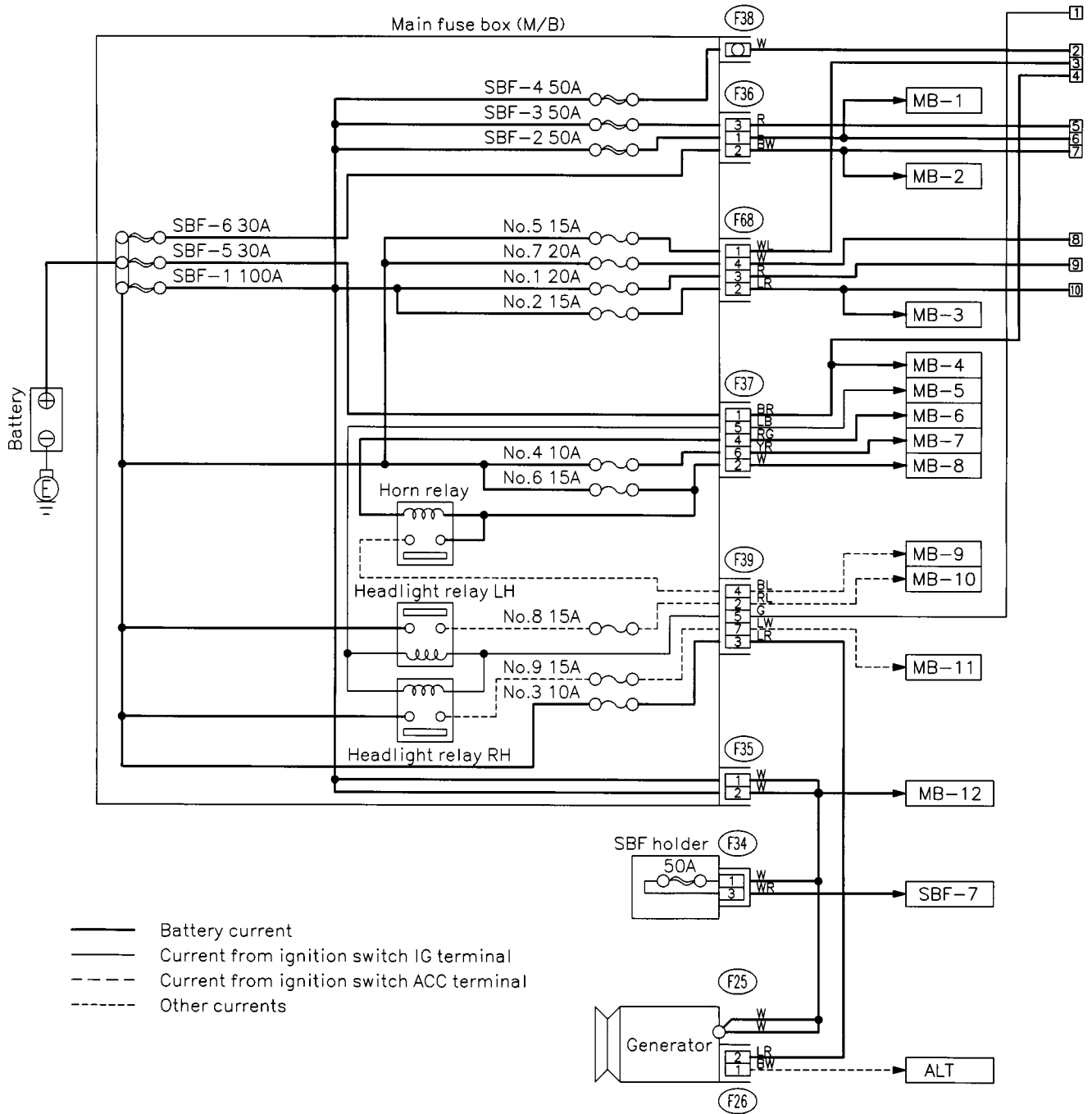

- Battery current
- Current from ignition switch IG terminal
- - - Current from ignition switch ACC terminal
- - - - Other currents

(F26) (Green) (F35) (Black) (F36) (F68) (Black) (F37) (Black) (F34) (Black) (F39) (Black)

BU01-20A

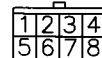

BU01-20A

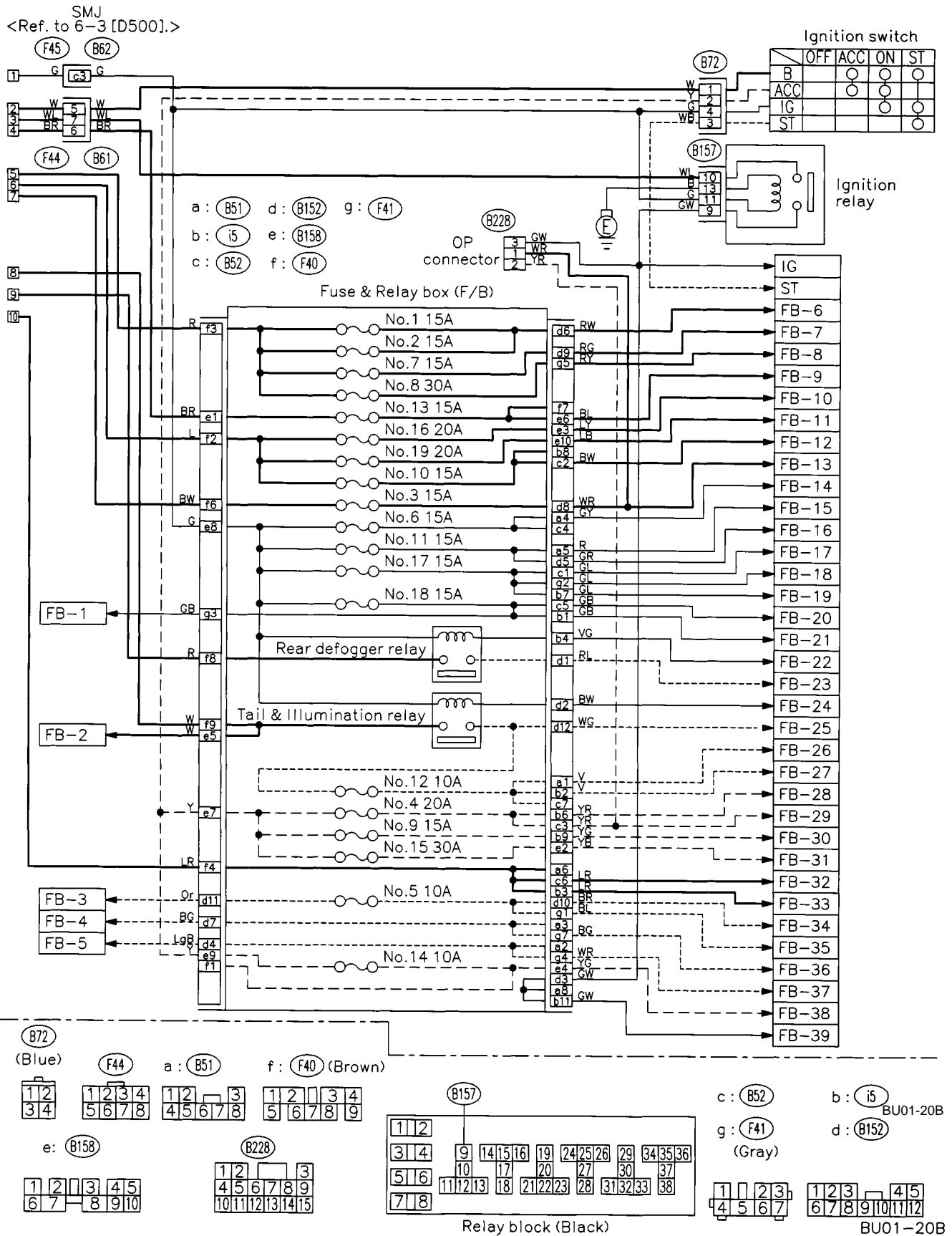

6. Wiring Diagram

No.	Load
MB-1	Fuse (Seat heater)
MB-2	Power window circuit breaker
MB-4	Data link connector Engine control module Main relay
MB-5	Daytime running light control module OP connector
MB-6	Cruise control sub switch Horn switch Keyless entry control module Security horn relay
MB-7	Transmission control module
MB-8	AT shift lock control module Hazard switch Key warning switch
MB-9	Horn
MB-10	Headlight LH
MB-11	Combination meter Front fog light relay Front fog light switch Headlight RH
MB-12	A/C relay holder (Fuse)
SBF-7	ABS control module
ALT	Combination meter
IG	Check connector Keyless entry control module Seat belt timer Security control module Vehicle speed sensor (MT)
ST	Cruise control module (AT) Engine control module Interrupt relay Starter interlock relay
FB-1	ABS control module Main fan relay
FB-2	Parking switch Security control module
FB-3	Parking switch Security control module
FB-4	Combination meter Hazard switch Rear turn signal light LH Trailer connector Turn signal switch
FB-5	Combination meter Hazard switch Rear turn signal light RH Trailer connector Turn signal switch
FB-6	Blower motor relay
FB-7	Front fog light relay
FB-8	ABS control module
FB-9	Fuel pump relay
FB-10	Stop light switch
FB-11	Wiper deicer relay
FB-12	Trailer connector

No.	Load
FB-13	Door lock timer Keyless entry control module
FB-14	Airbag control module
FB-15	Airbag control module
FB-16	Daytime running light control module Engine control module Fuel pump relay Ignition coil and ignitor Transmission control module
FB-17	A/C pressure switch Blower motor relay
FB-18	A/C relay Sub fan relay
FB-19	Mode control panel
FB-20	AT shift lock control module Back-up light switch (MT) Cruise control module Inhibitor switch (AT) Power window relay Wiper deicer relay Wiper deicer timer
FB-21	Cruise control main switch
FB-22	Engine control module Rear defogger switch
FB-23	Rear defogger Rear defogger condenser
FB-24	Engine control module Lighting switch OP connector
FB-25	Parking switch
FB-26	Illumination control module Illumination light OP connector
FB-27	Combination meter Illumination light
FB-28	Front accessory power supply socket
FB-29	AT shift lock control module Mirror heater LH Mirror heater RH Remote control rearview mirror switch Seat heater relay Vanity mirror illumination light
FB-30	Radio
FB-31	Front washer motor Front wiper motor Front wiper & washer switch
FB-32	Luggage room light Room light Security control module Security horn relay Spot light Step light Trunk room light
FB-33	Combination meter Radio

No.	Load
FB-34	License plate light LH License plate light RH Rear finisher light LH Rear finisher light RH Tail light LH Tail light RH Trailer connector
FB-35	Front clearance light LH Front clearance light RH
FB-36	Front turn signal light LH
FB-37	Front turn signal light RH
FB-38	Rear washer motor Rear wiper motor Rear wiper relay
FB-39	Combination meter Hazard switch

B: GROUND DISTRIBUTION

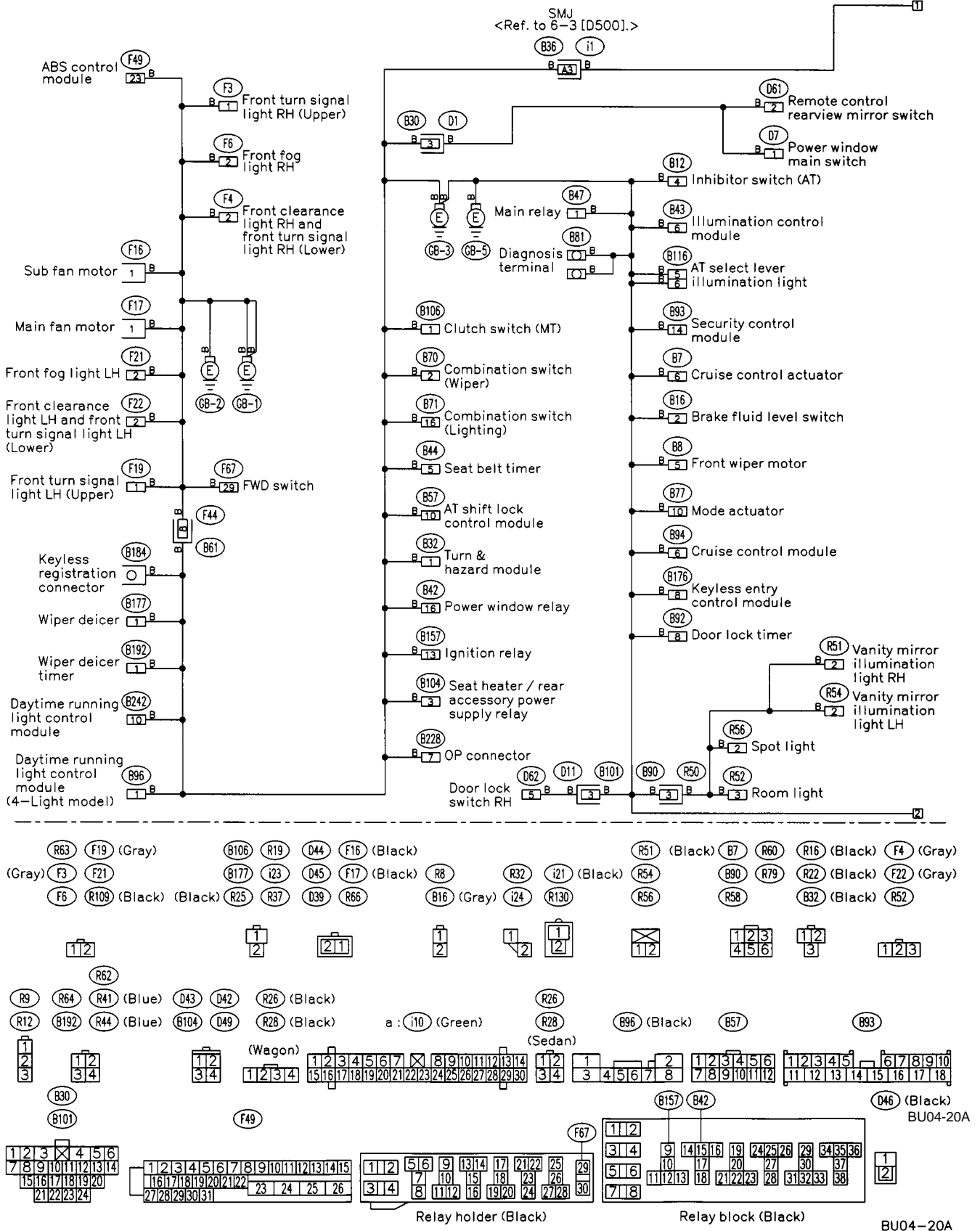

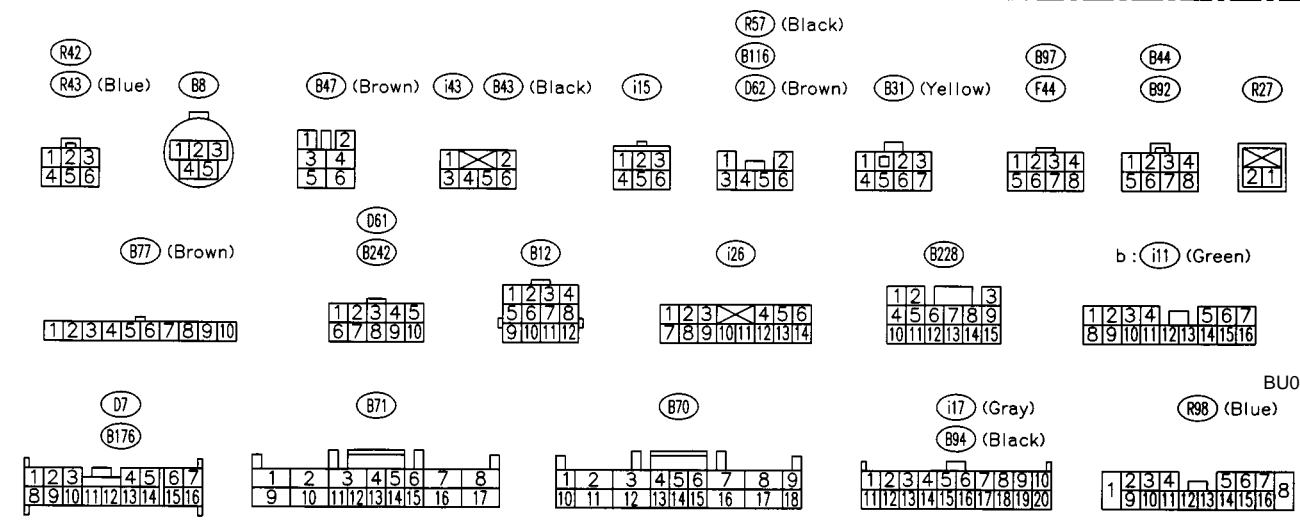
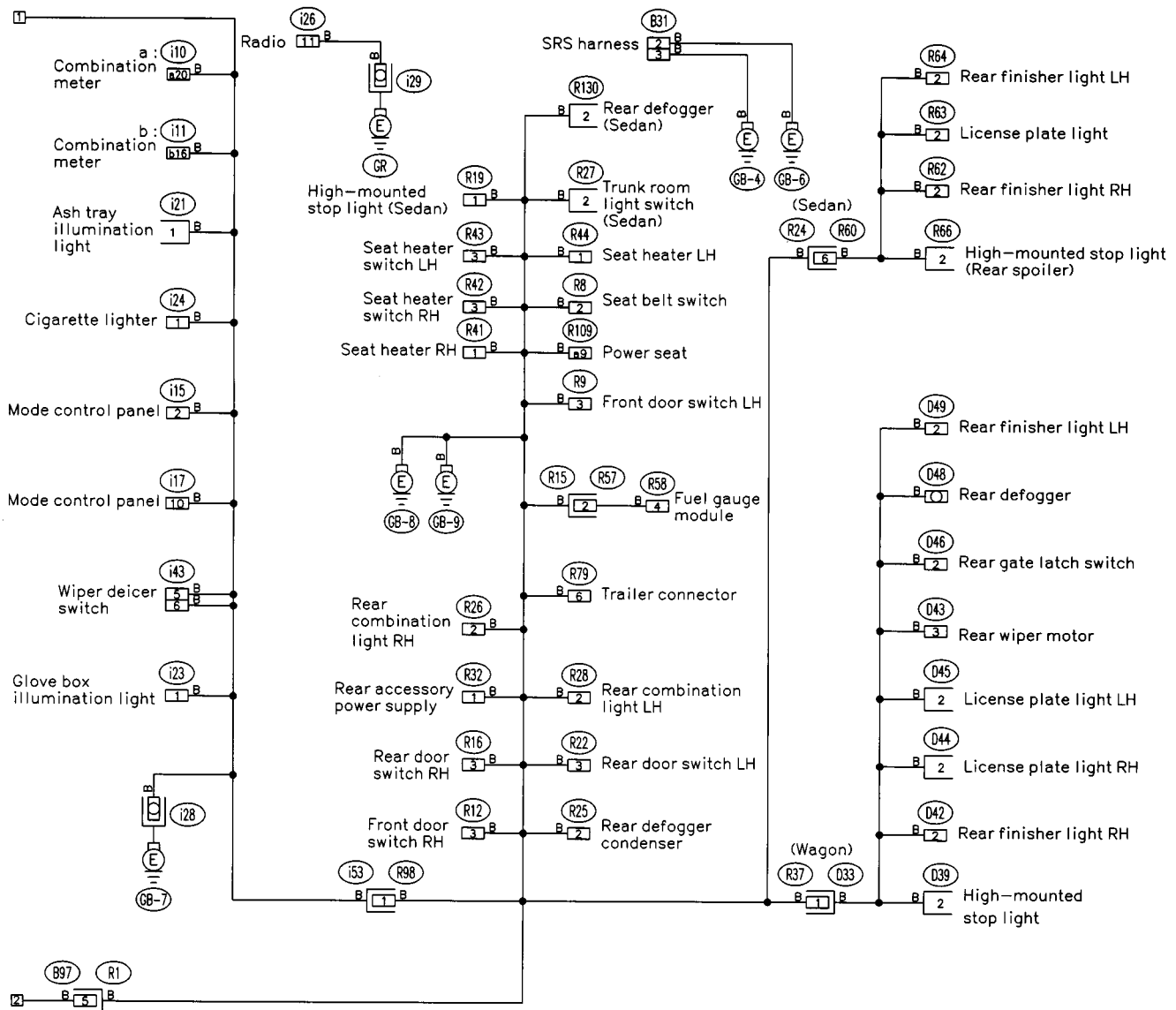

BU04-20B

BU04-20B

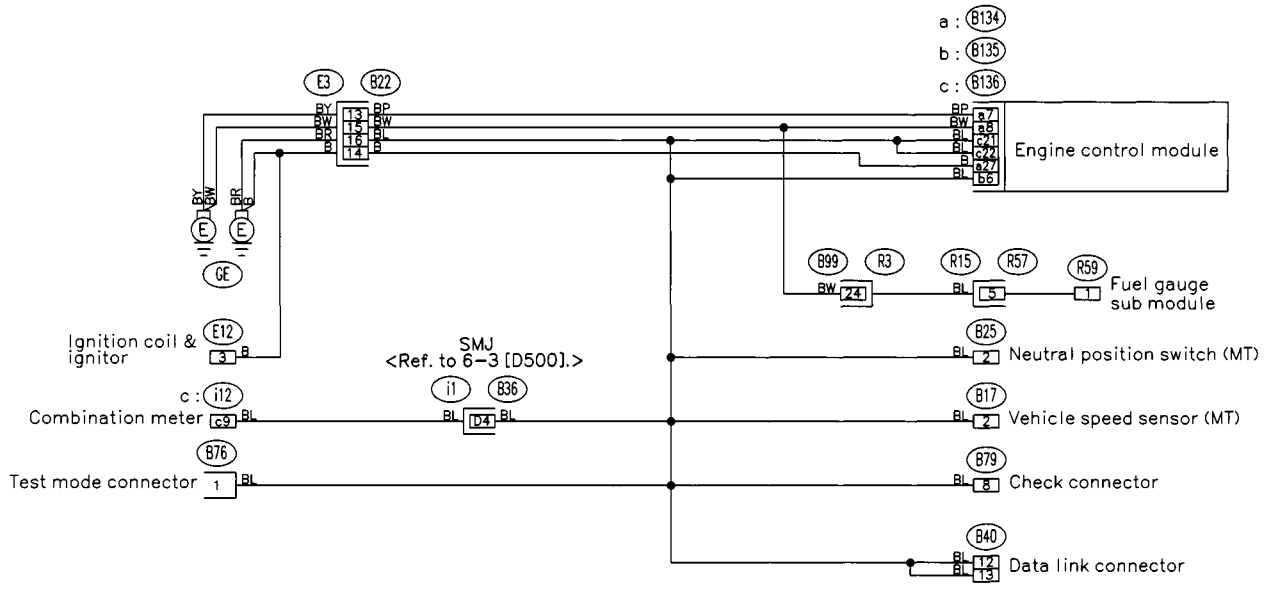
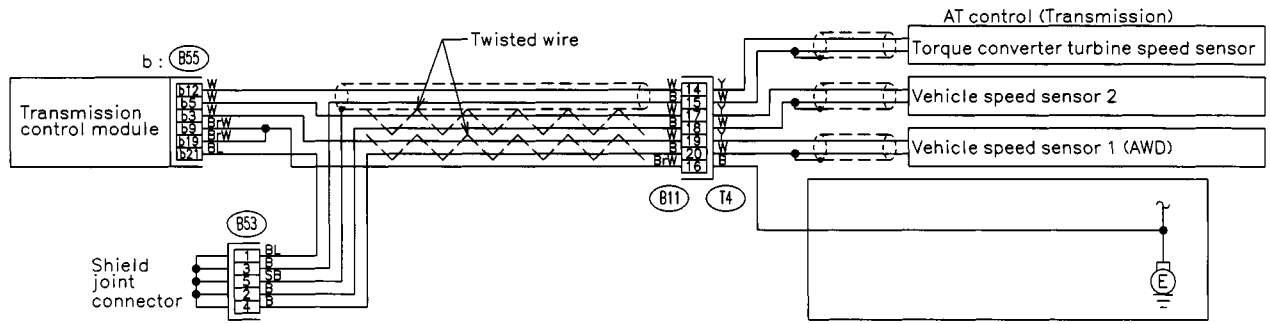

- (B25) (Brown)
- (B76) (Green)
- (B17)
- c: (i12)
- (B79) (Gray)
- (B40) (Gray)
- (E12) (Dark gray)
- (R59)

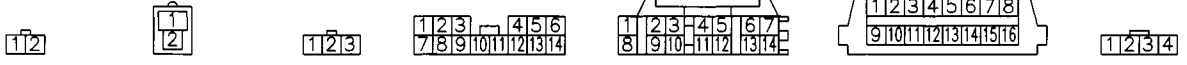

- (B22) (Brown)
- a: (B134) AT: (Gray)
MT: (Non-colored)
- b: (B135) AT: (Gray)
MT: (Non-colored)
- c: (B136) AT: (Gray)
MT: (Non-colored)

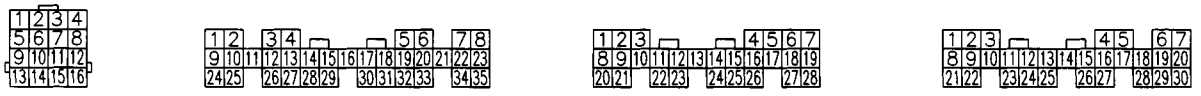

- (B53) (Gray)
- (B11) (Black)
- (R57) (Black)
- b: (B55) (Gray)
- (B99)
- BU04-20C

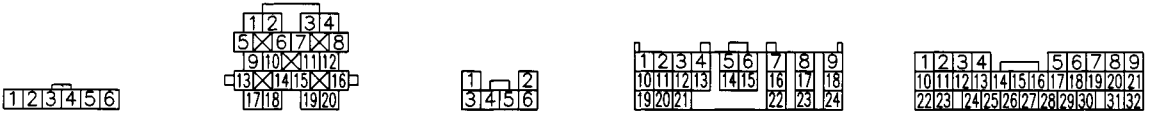

BU04-20C

C: AIRBAG SYSTEM

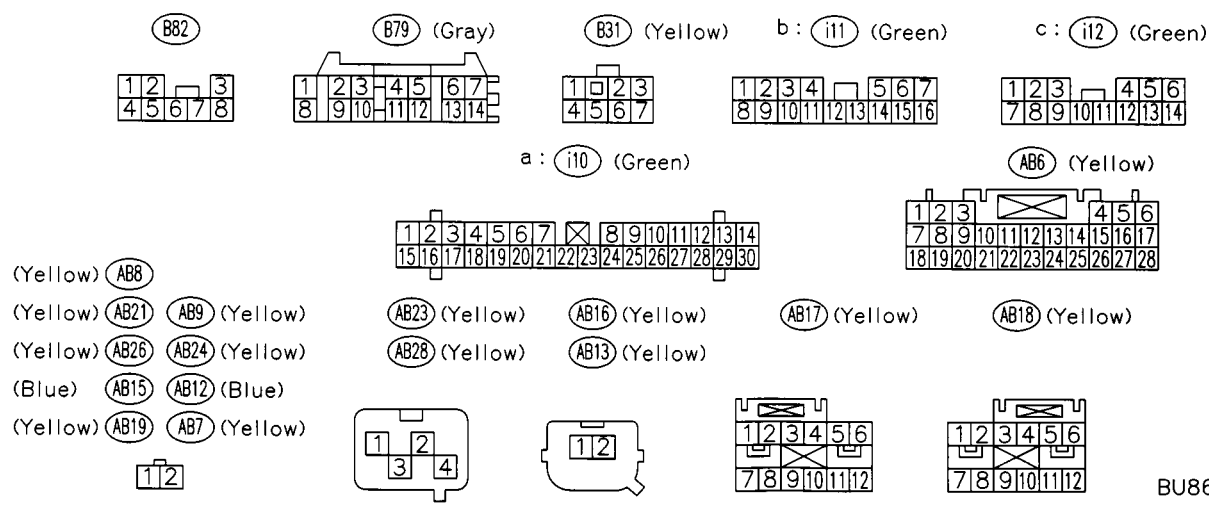
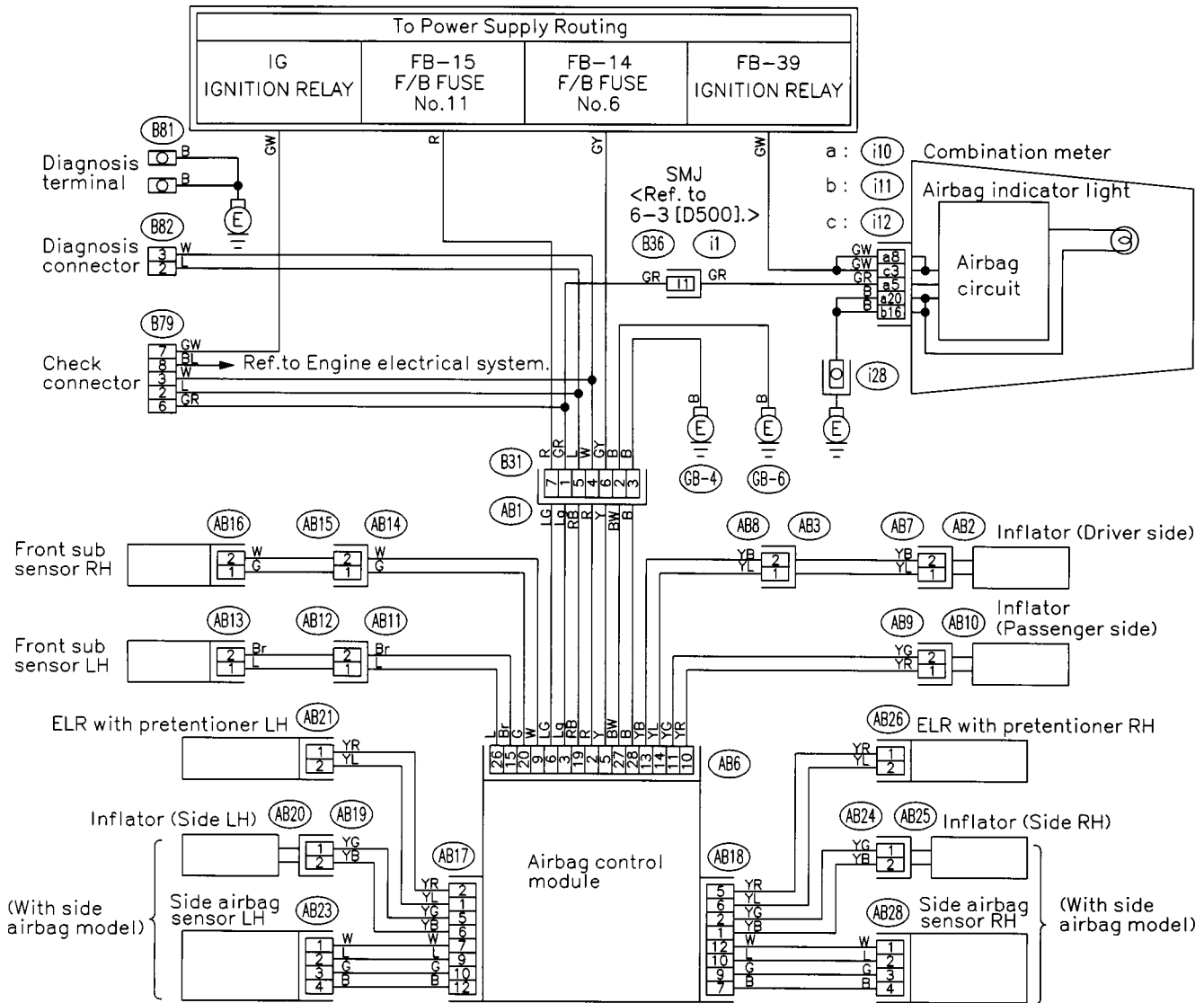

BU86-20

BU86-20

D: AIR CONDITIONING SYSTEM

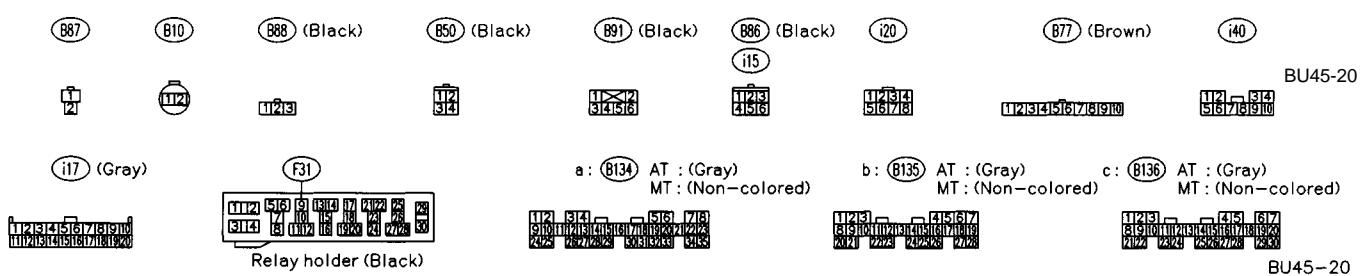
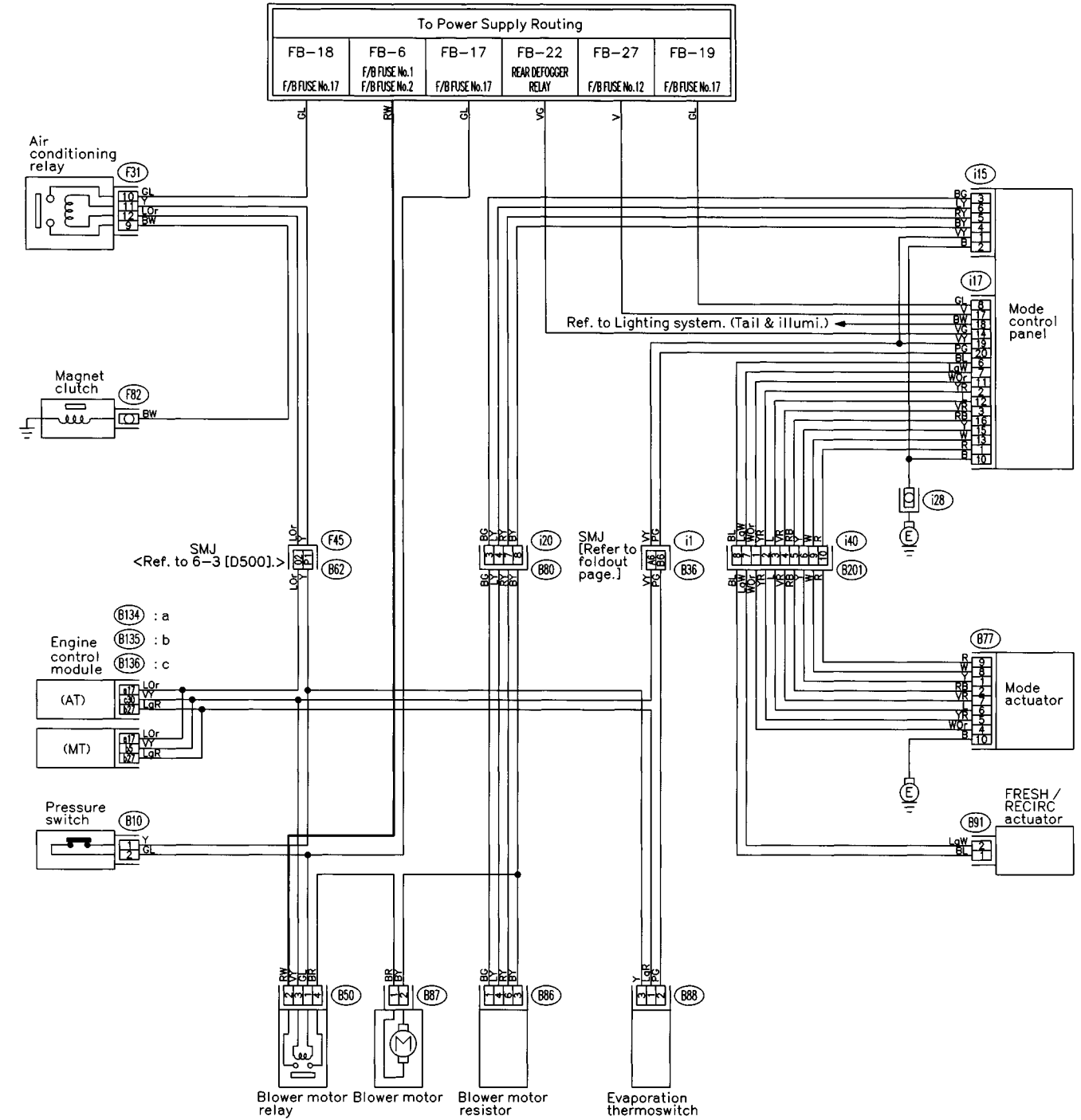

MEMO:

E: ANTI-LOCK BRAKE SYSTEM

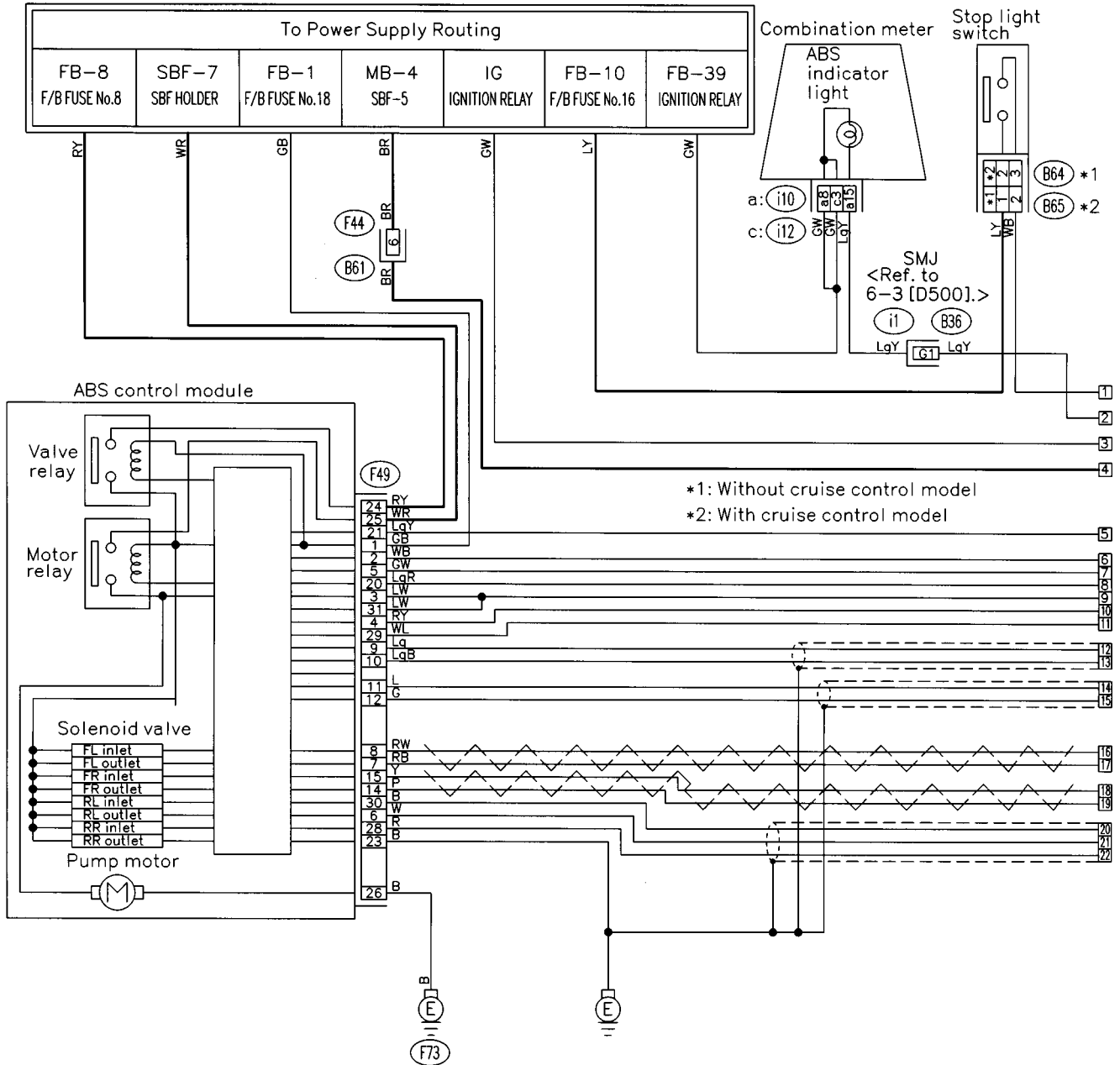

B64 (Black)

B65 (Black)

F44

F49 (Black)

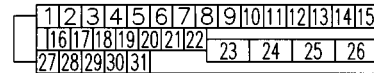

BU82-20A

a: (i10)

c: (i12)

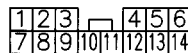
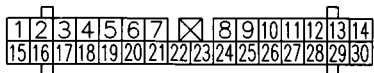

BU82-20A

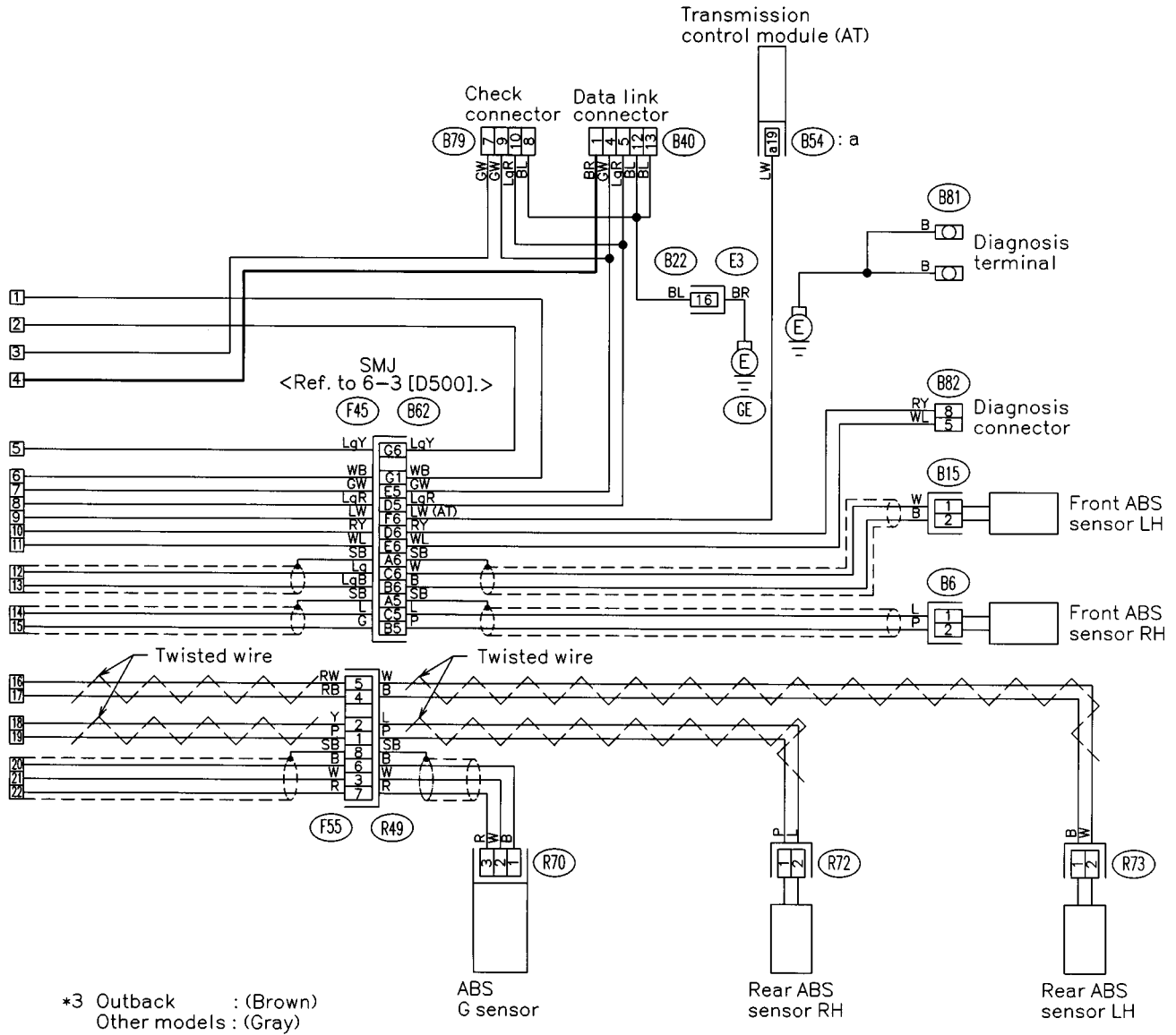

*3 Outback : (Brown)
Other models : (Gray)

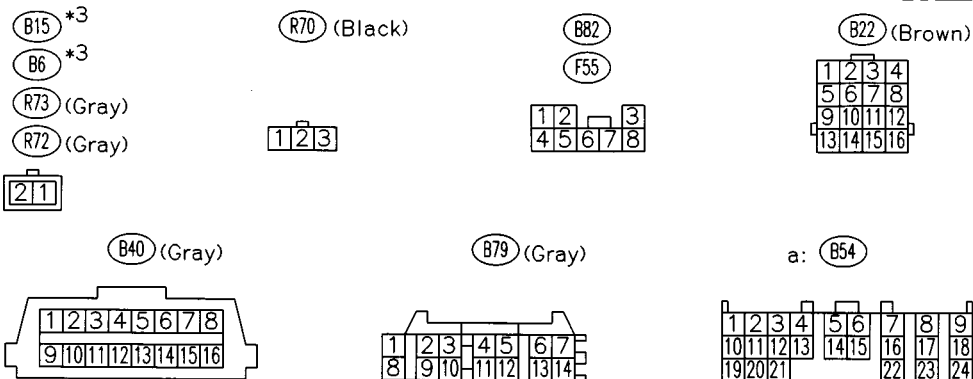

BU82-20B

BU82-20B

F: A/T CONTROL SYSTEM

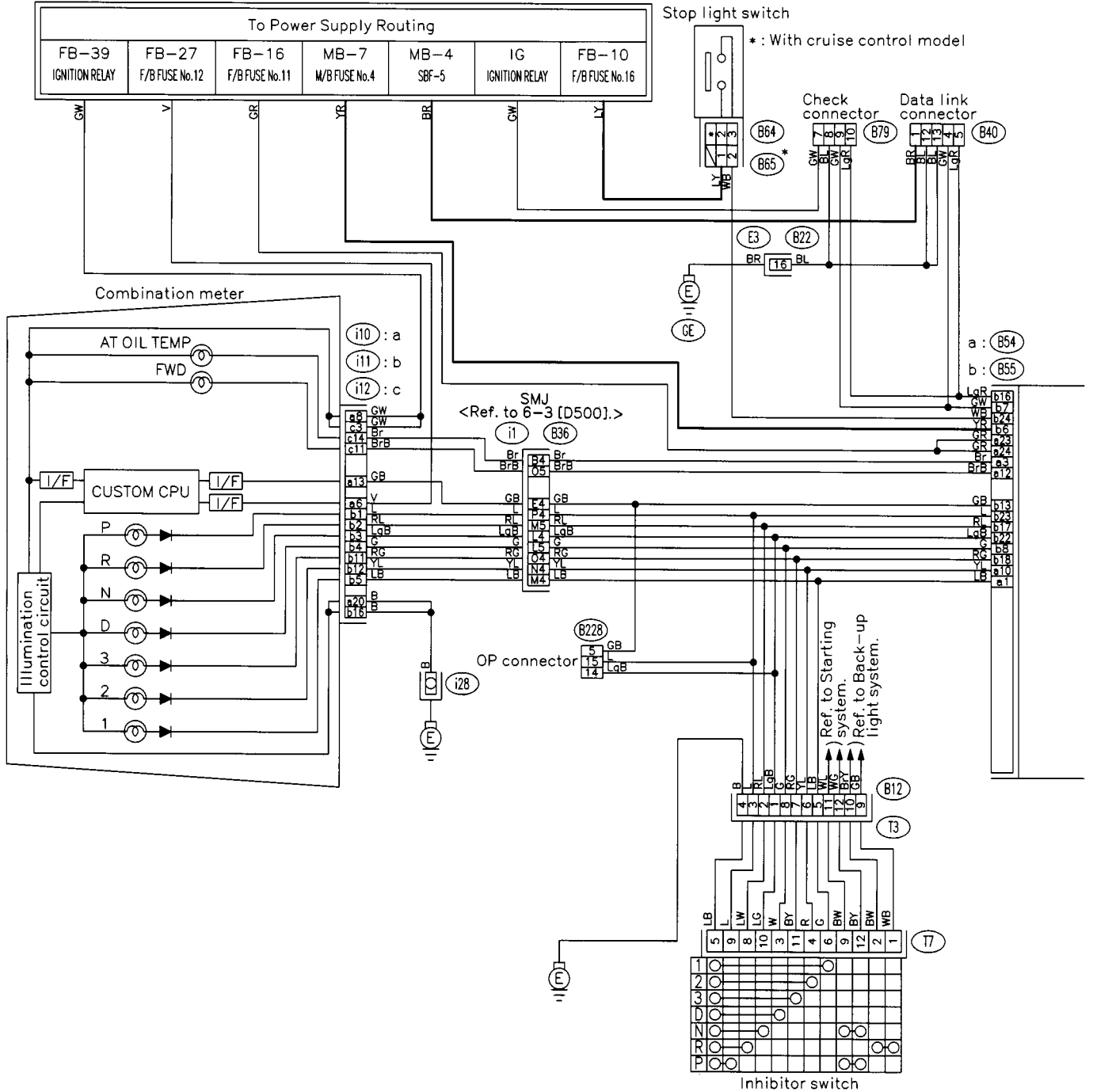

c : (i12) (Green) b : (i11) (Green) (B65) (Black) a : (i10) (Green) (B12) (Black)

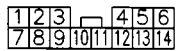

(B228)

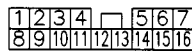

(F44)

(B64) (Black)



(B79) (Gray)

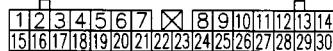

(T7)

(B40) (Gray)

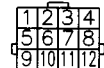

(B22) (Brown)
BU41-20A

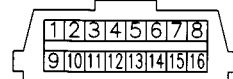
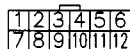
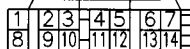
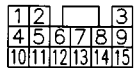

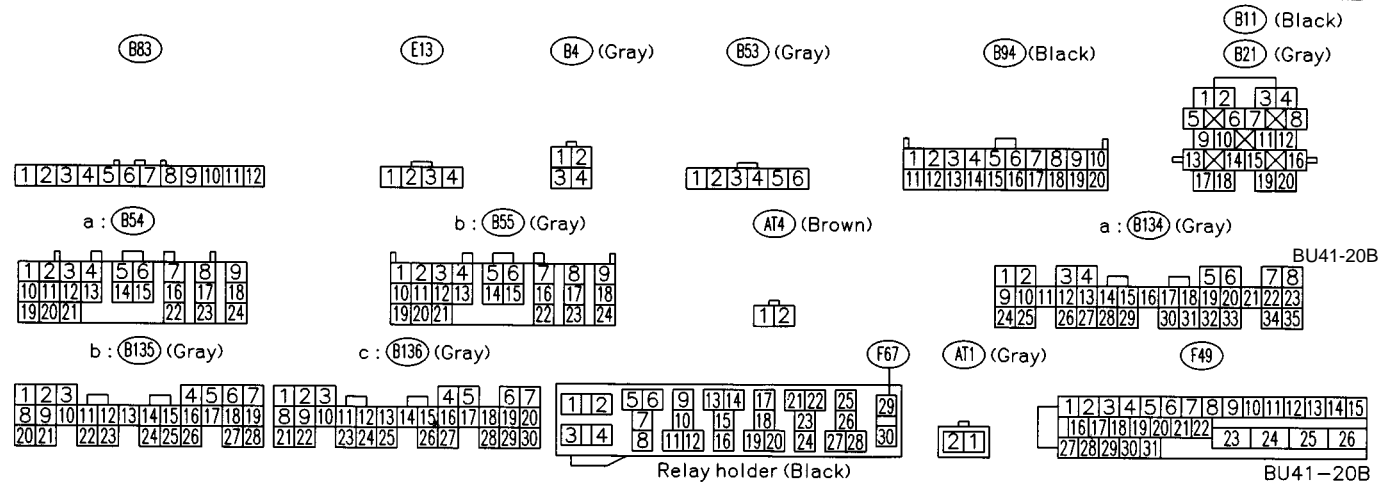
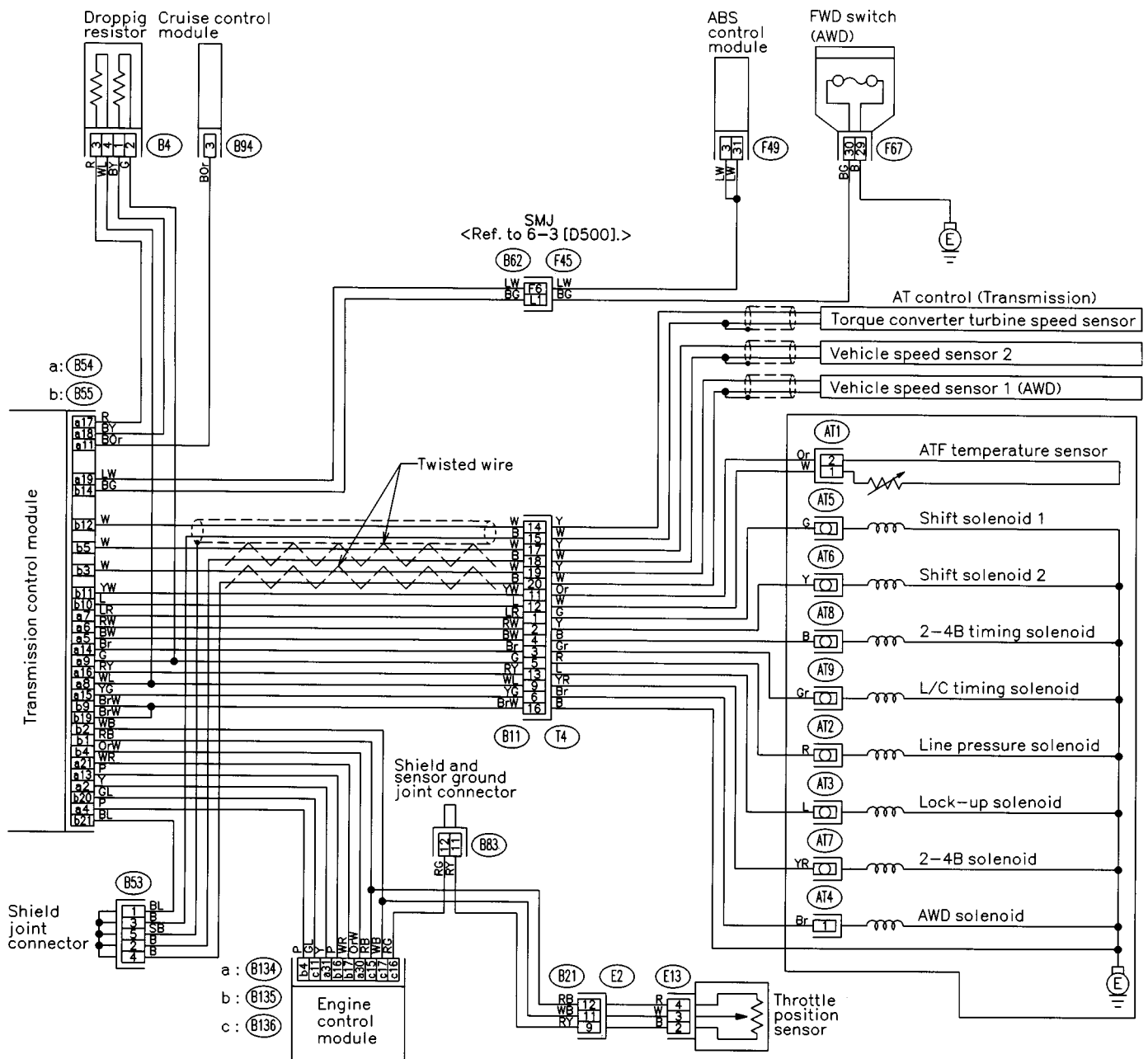

G: A/T SHIFT LOCK CONTROL SYSTEM

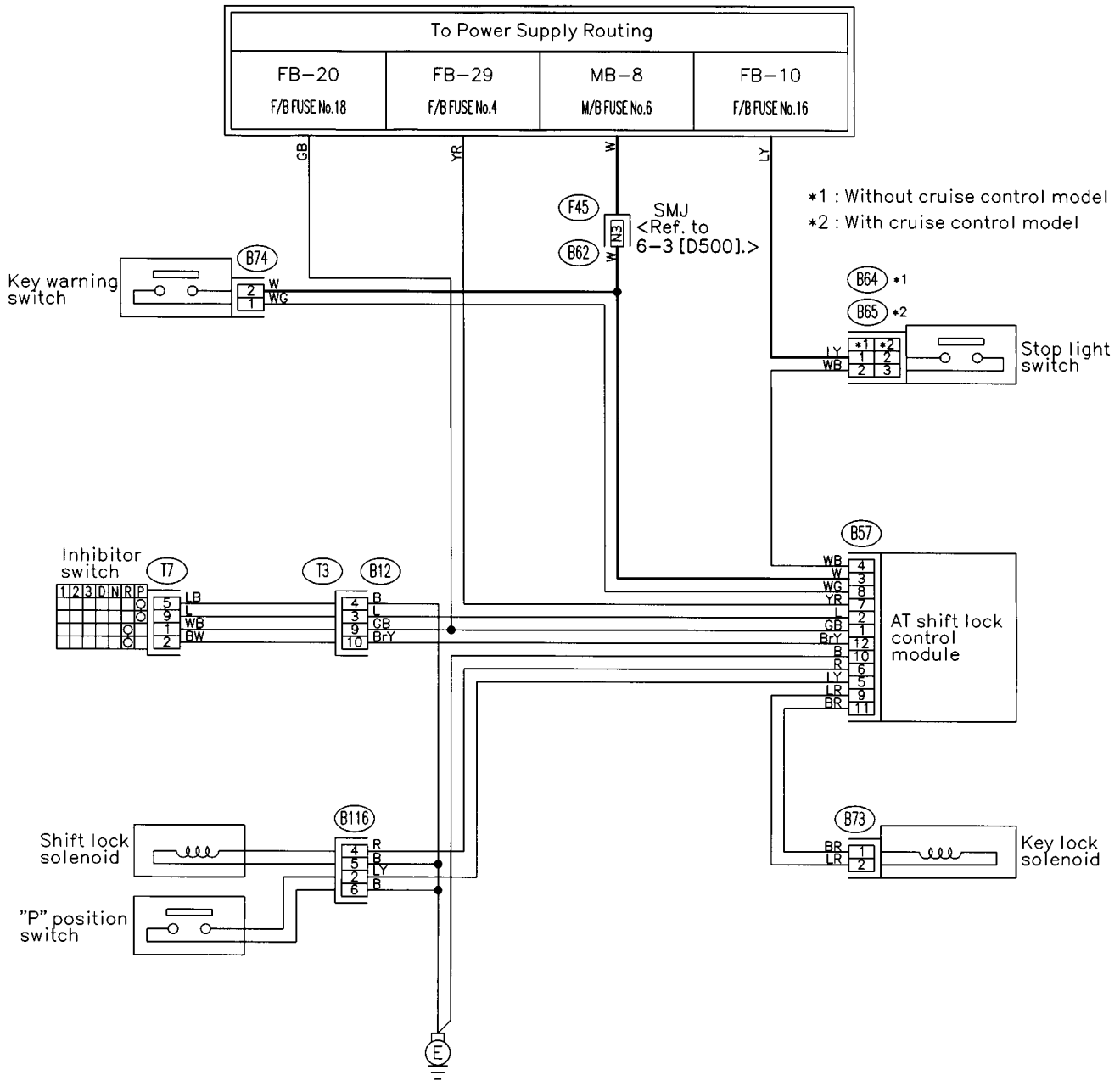

- (B74) (Black)
- (B64) (Black)
- (B65) (Black)
- (B116)
- (B12) (Black)
- (T7)
- (B73)
- (B57)

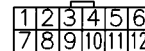
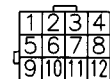

BU42-20

BU42-20

H: AUDIO SYSTEM

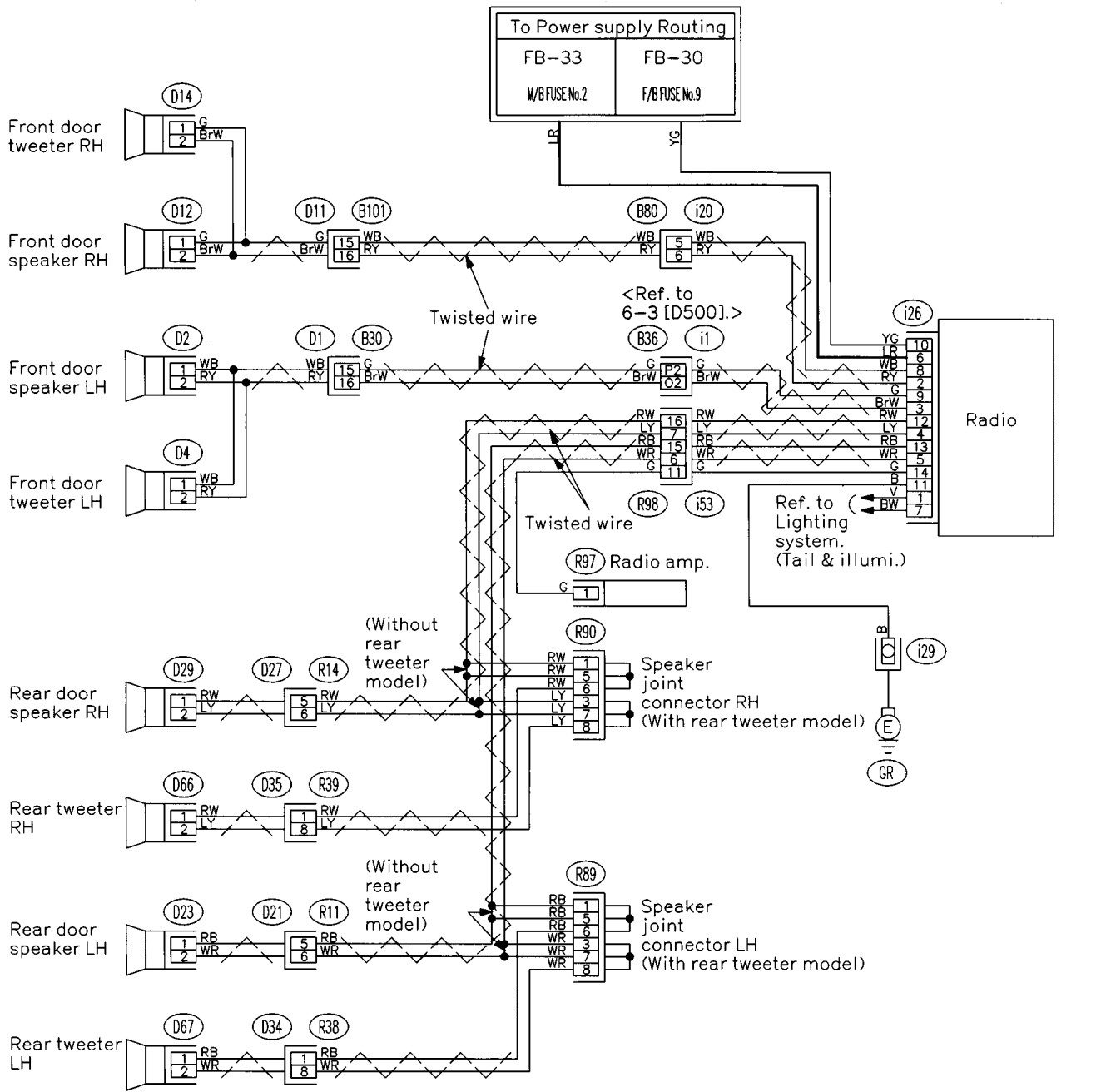

(R98) (Blue)

i26

B30

D2

B101

D12

R97



(Black) (D66) (D4) (Black)
(Black) (D67) (D14) (Black)

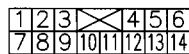

i20
R89 R90

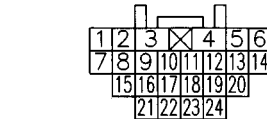
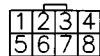

R11 D34
R14 D35 (Black)

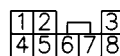

(D29) (Black)
(D23) (Black)

BU76-20

I: CHARGING SYSTEM

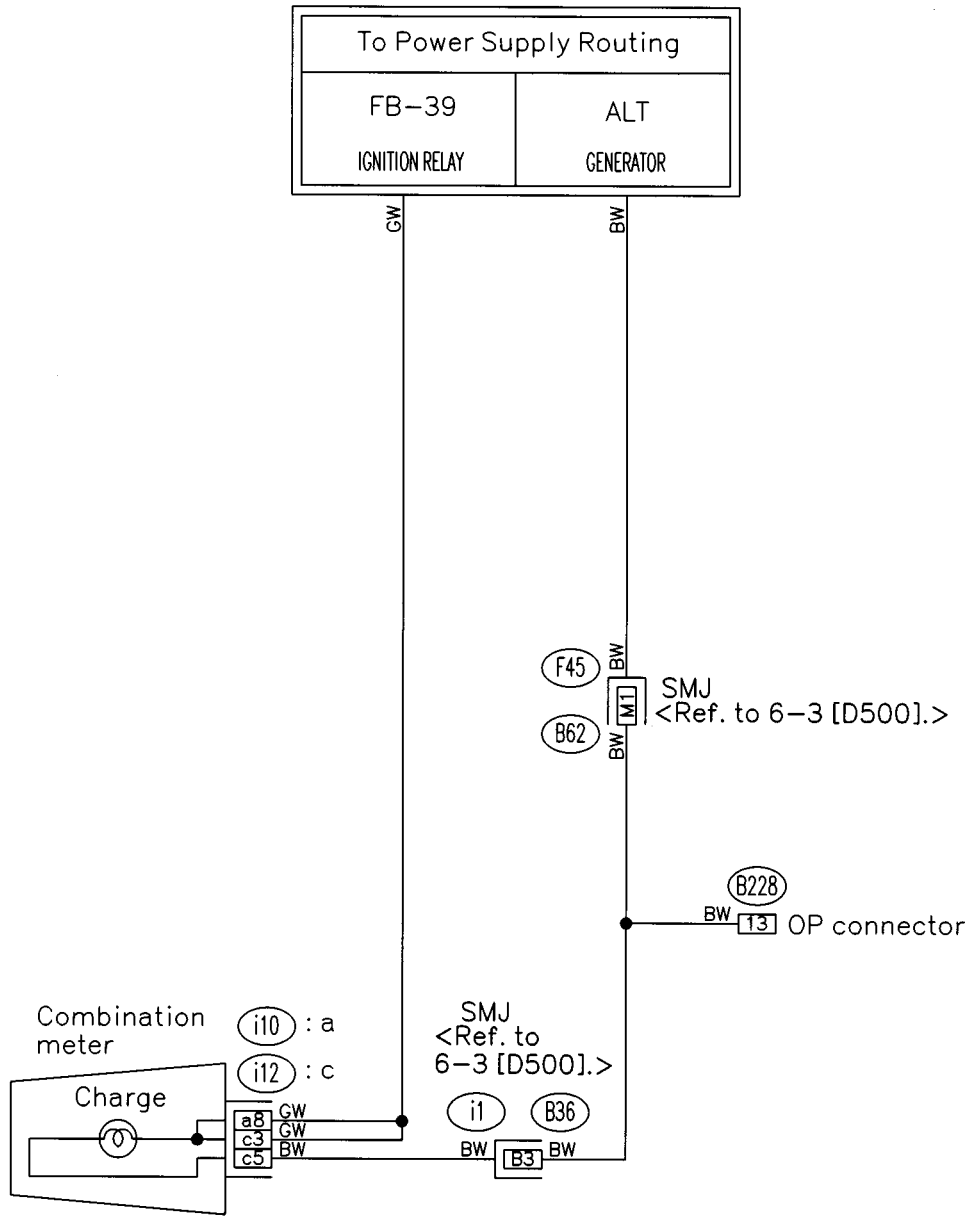

B228

c : i12 (Green)

a : i10 (Green)

1	2		3		
4	5	6	7	8	9
10	11	12	13	14	15

1	2	3		4	5	6	
7	8	9	10	11	12	13	14

1	2	3	4	5	6	7	⊗	8	9	10	11	12	13	14	
15	16	17	18	19	20	21	22	23	24	25	26	27	28	29	30

BU02-20

BU02-20

MEMO:

J: COMBINATION METER

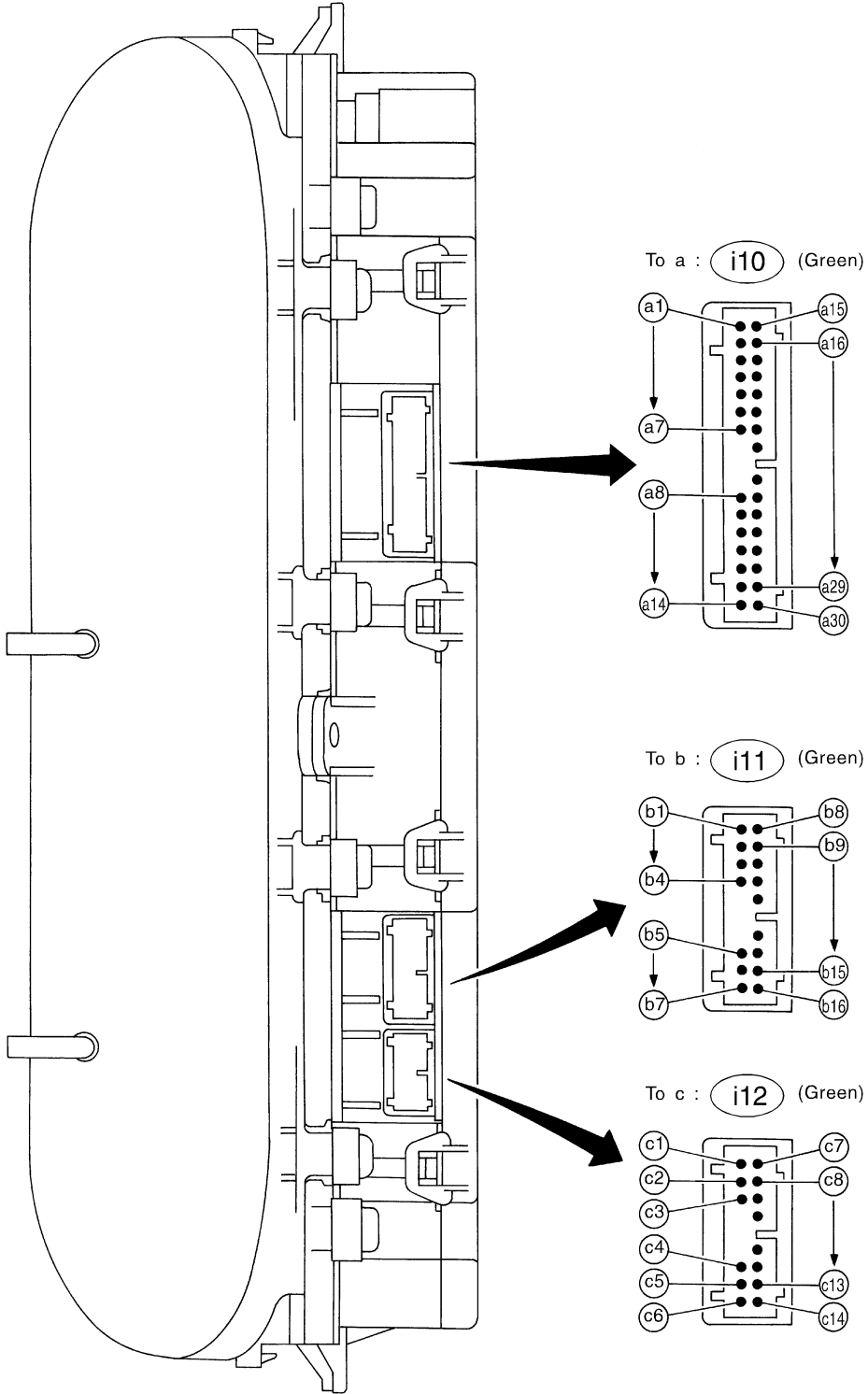

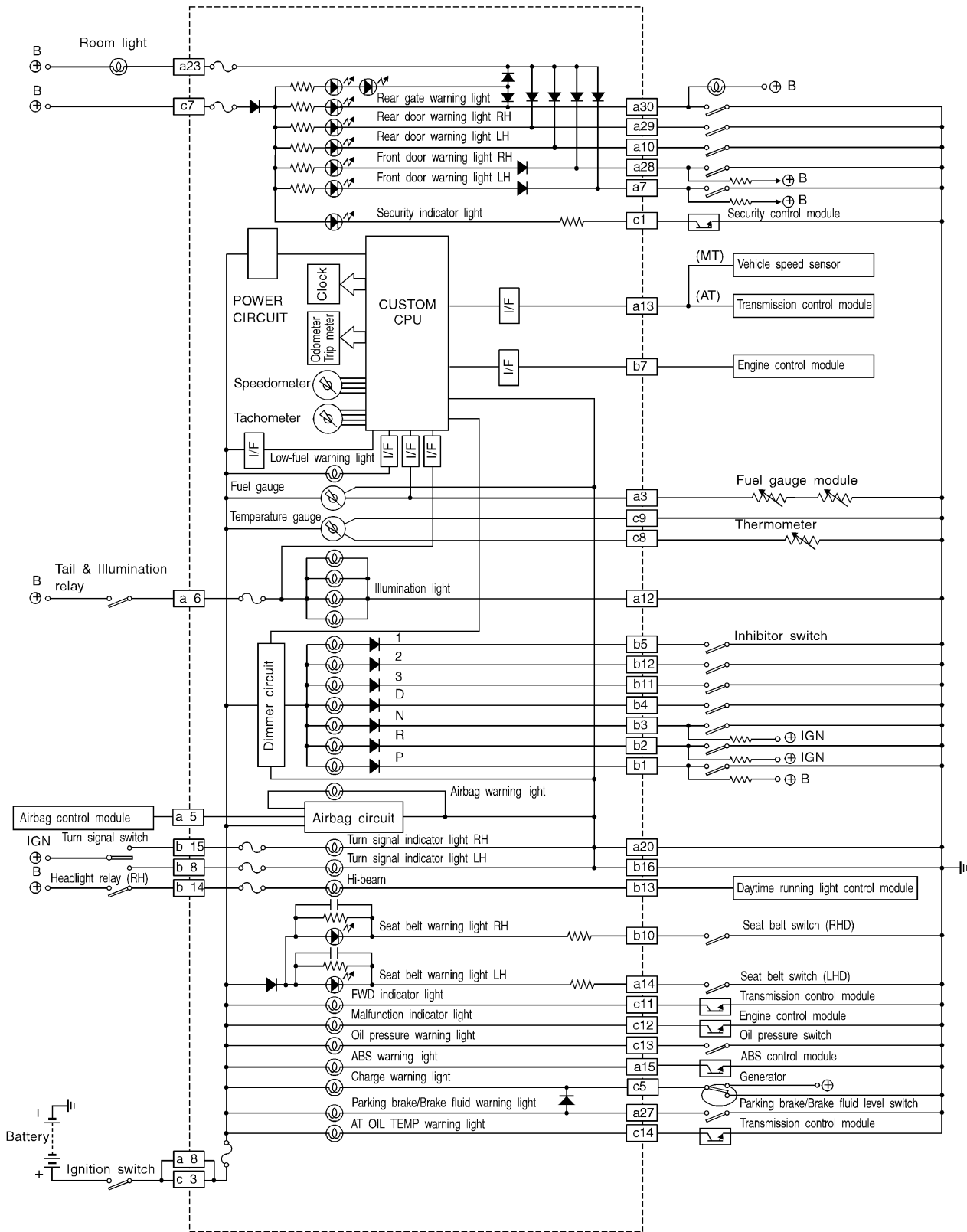

BU64-20B

K: CRUISE CONTROL SYSTEM

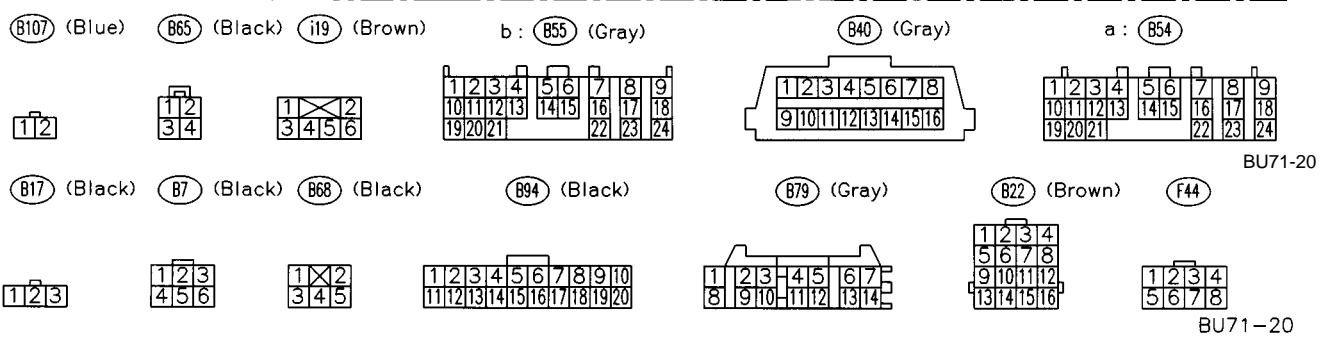
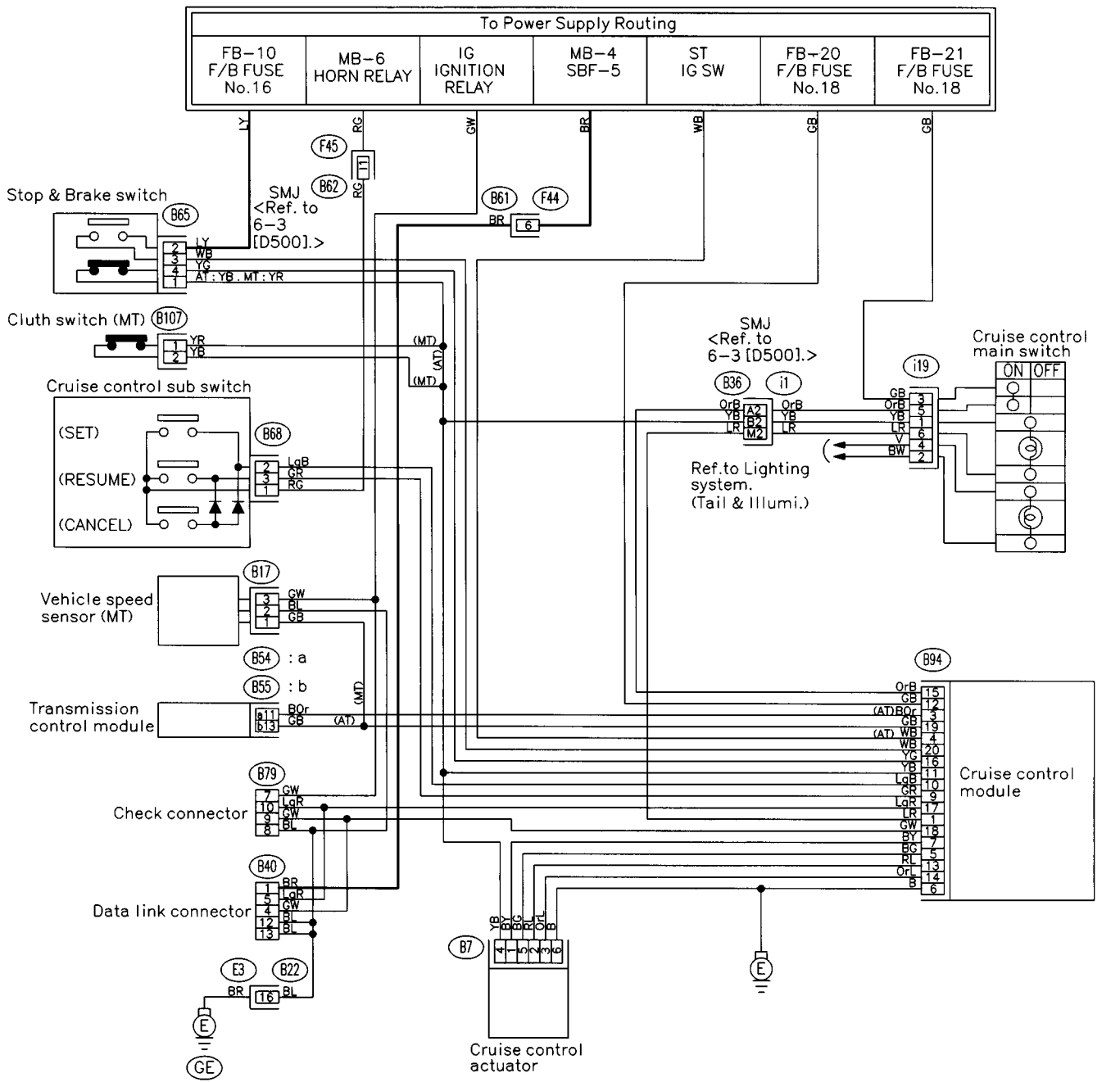

L: DOOR LOCK SYSTEM

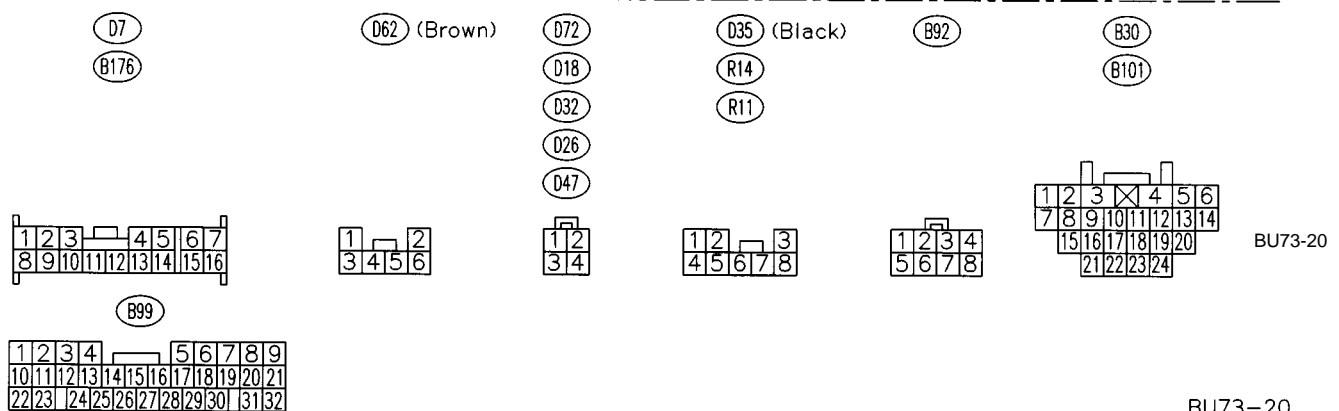
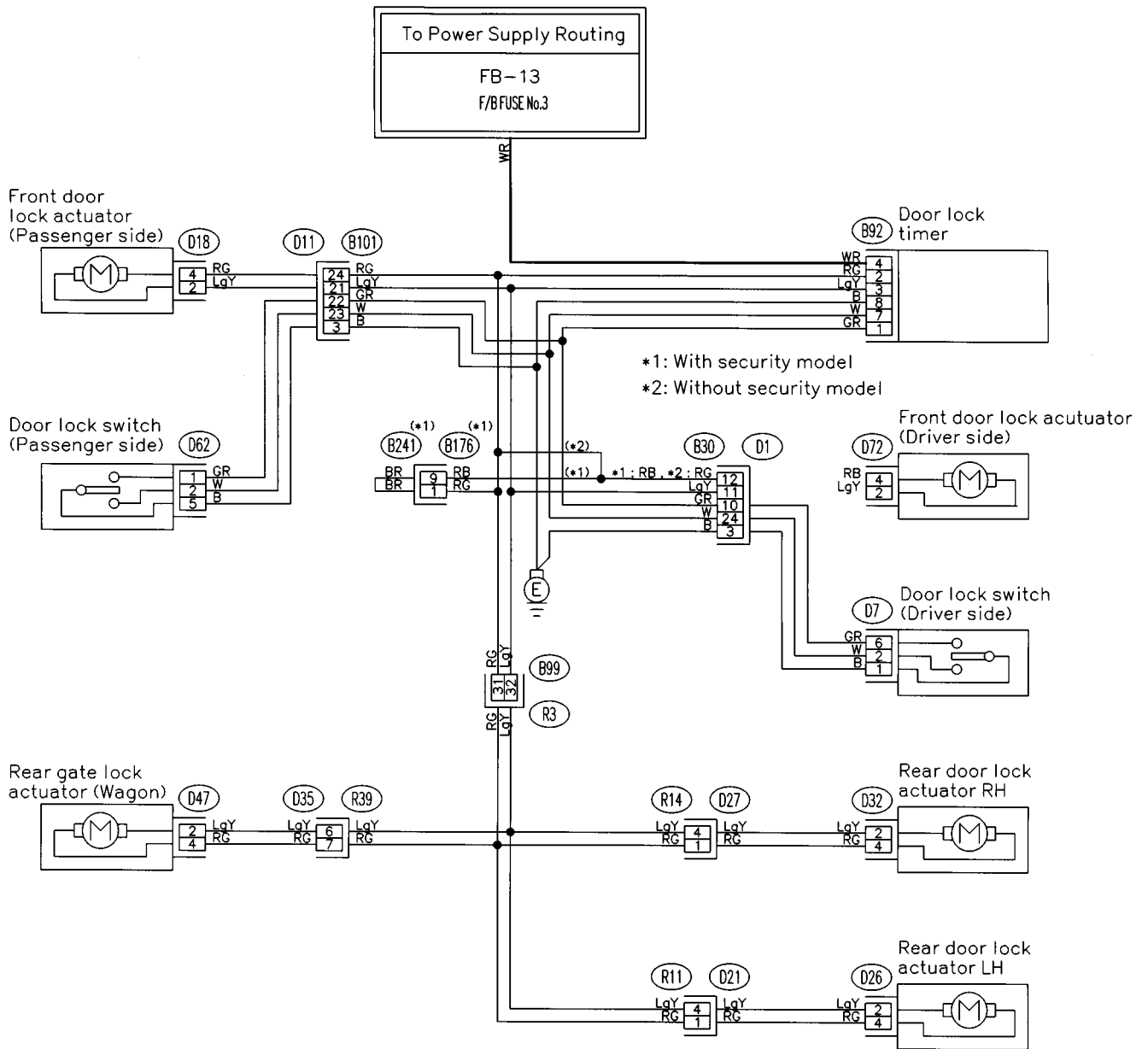

M: ENGINE ELECTRICAL SYSTEM

1. MT MODEL

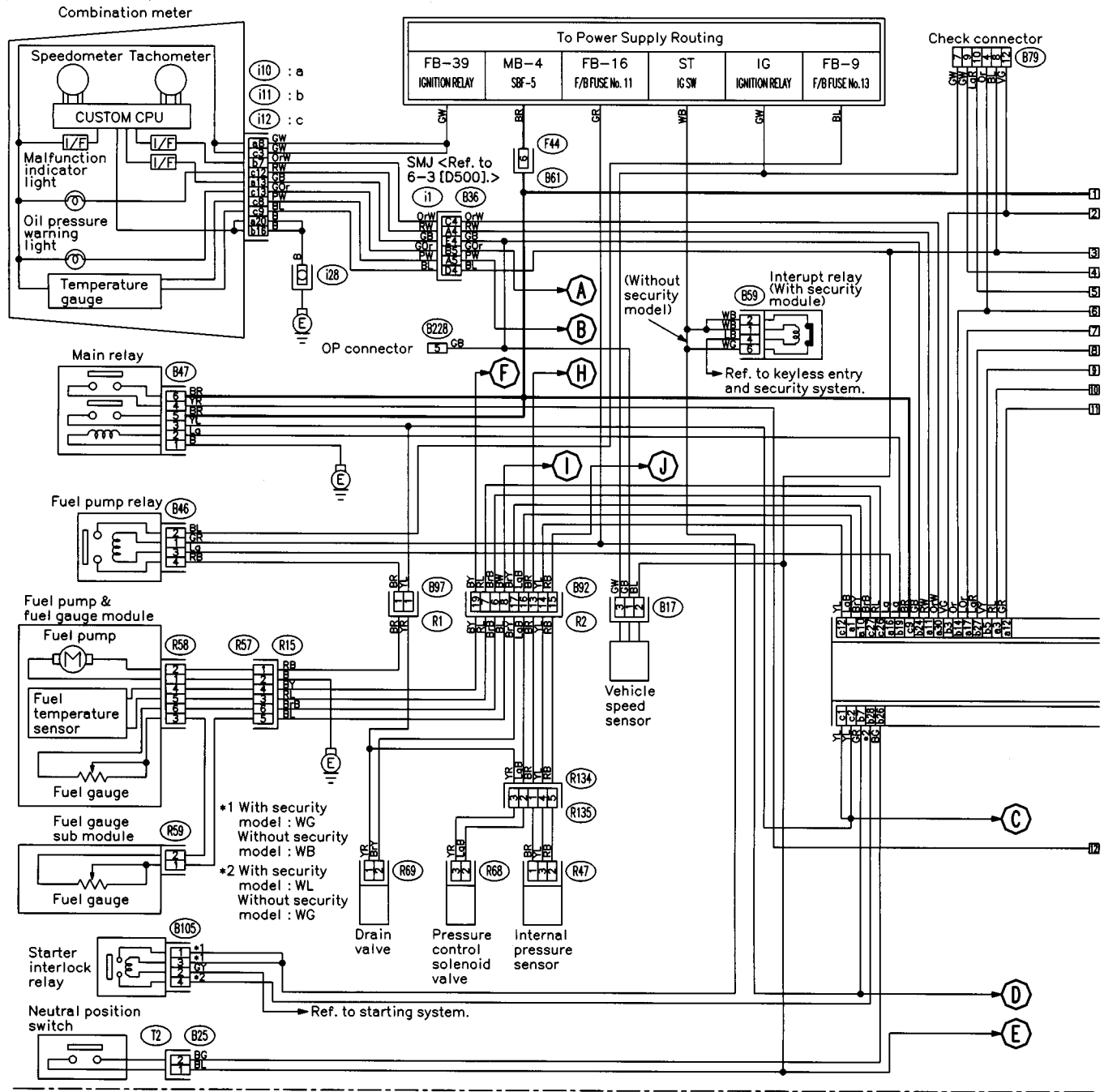

- (B25) (Brown)
- (B17) (Black)
- (B105) (Blue)
- (B46) (Green)
- (R135) (Gray)
- (R57) (Black)
- (R58) (Gray)
- (B47) (Brown)
- (B59)
- (B79) (Gray)
- (R59)
- (R47) (Black)
- (R68) (Gray)
- (R69)

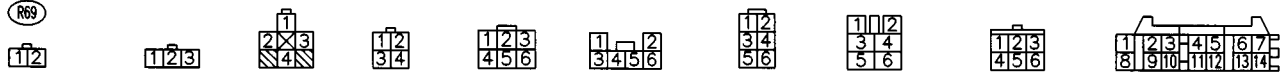

BU10-21A

- c : (i12) (Green)
- b : (i11) (Green)
- (B97)
- (B228)
- a : (i10) (Green)
- (B99)
- (F44)

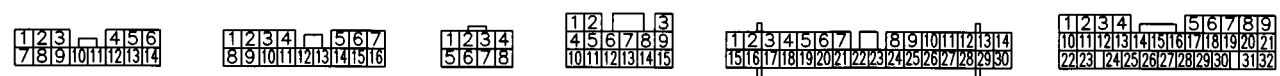

BU10-21A

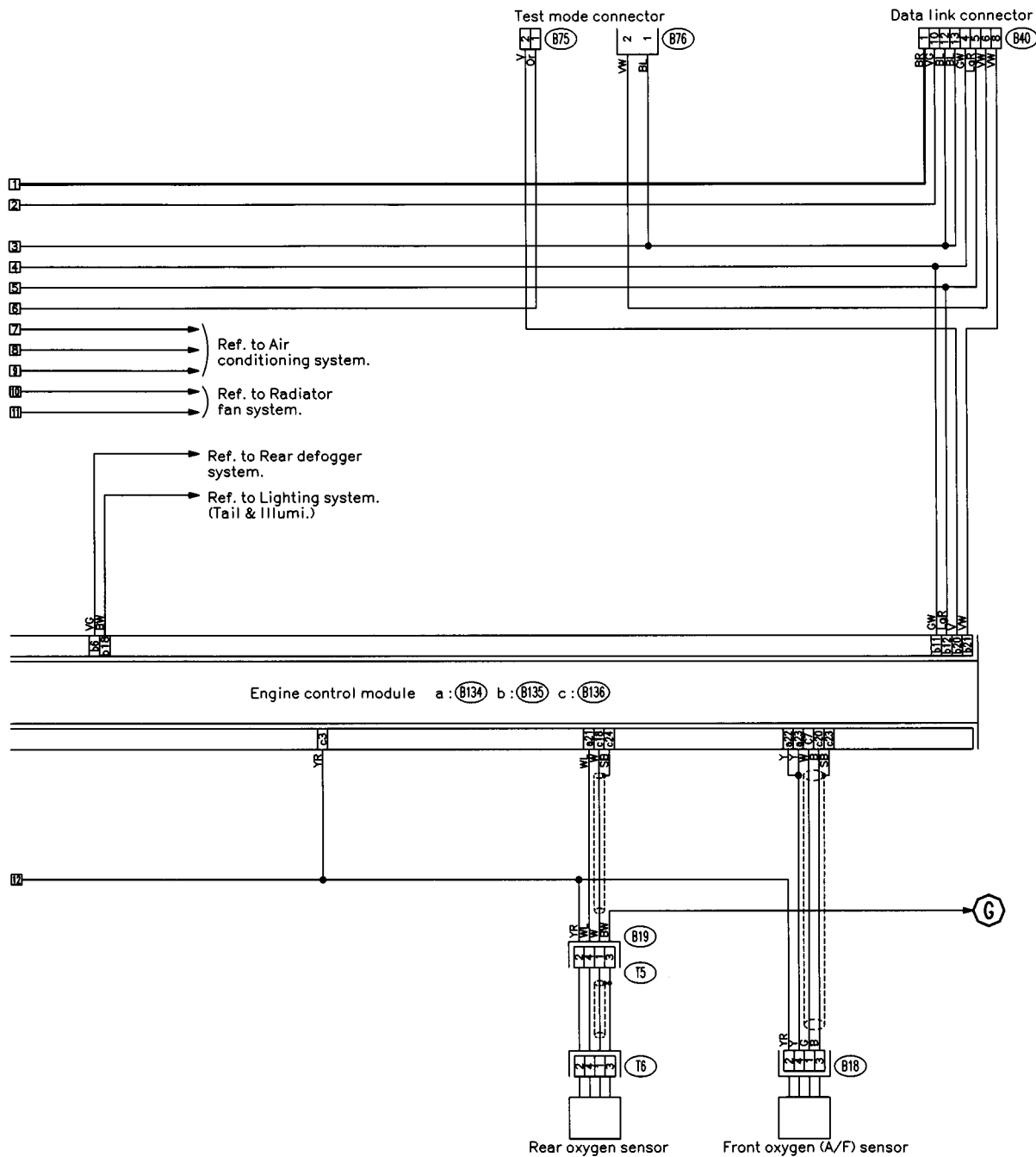

(B75) (Green)

(B76) (Green)

(B19) (Gray)

(B18) (Gray)

(B40) (Gray)

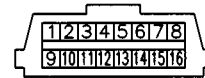

a: (B134)

b: (B135)

c: (B136)



BU10-21B

BU10-21B

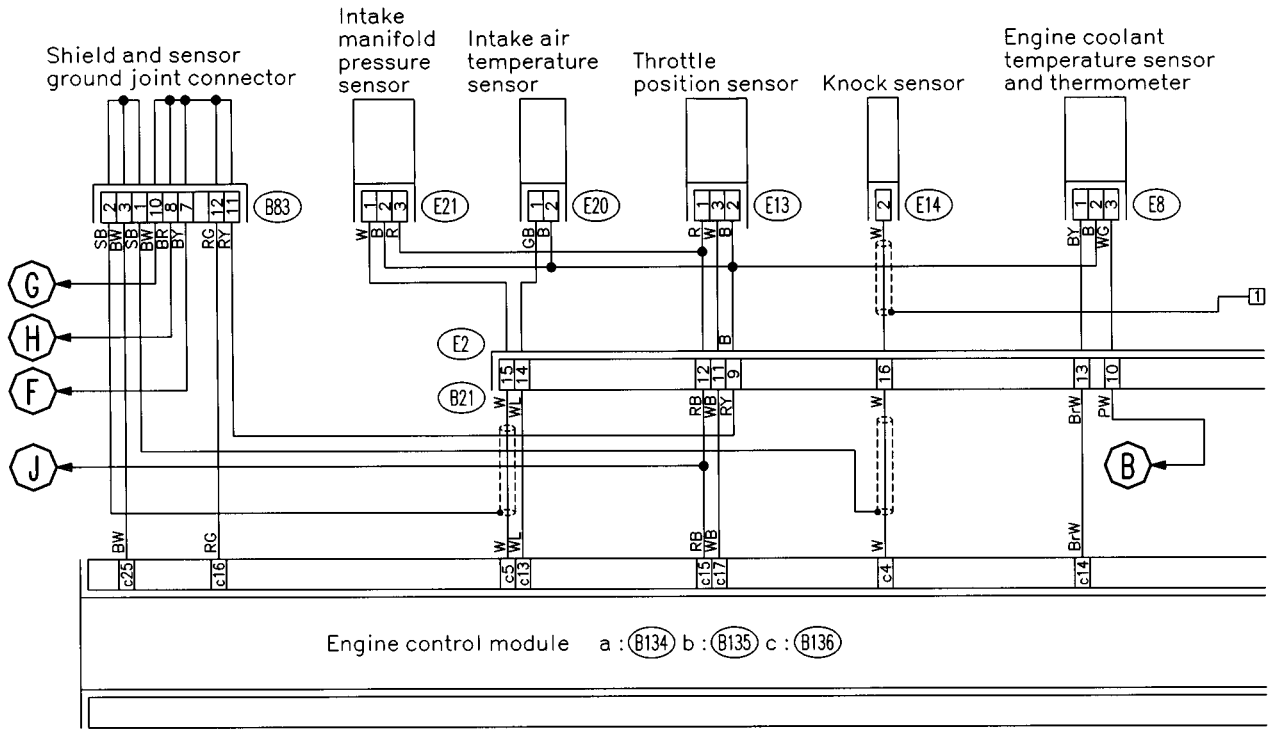

(E14) (Gray)

(E20) (Black)



(E13)

(E21)

(E7) (Gray)



(E8)



(B83) (Blue)

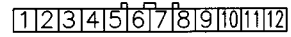

BU10-21C

BU10-21C

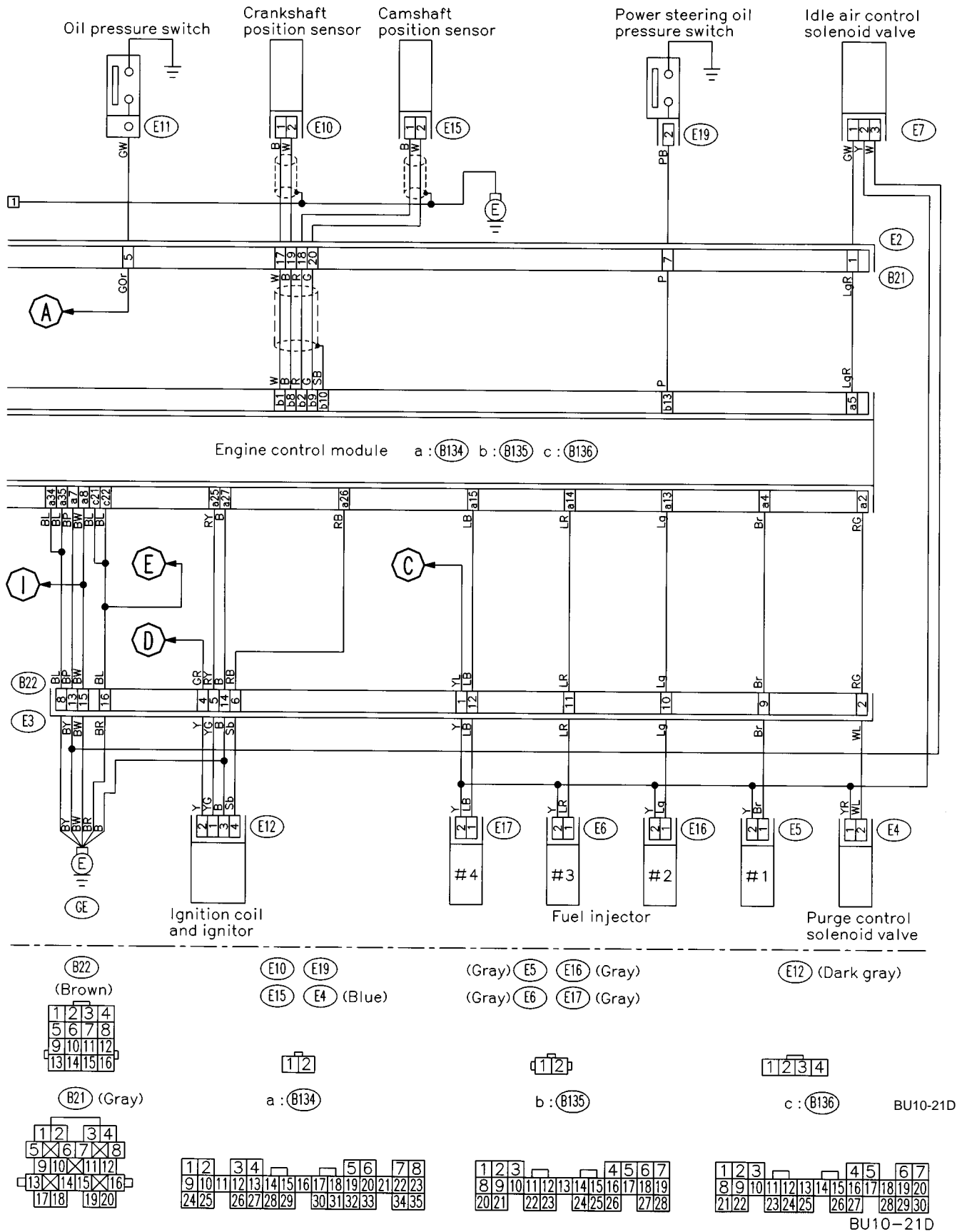

2. AT MODEL

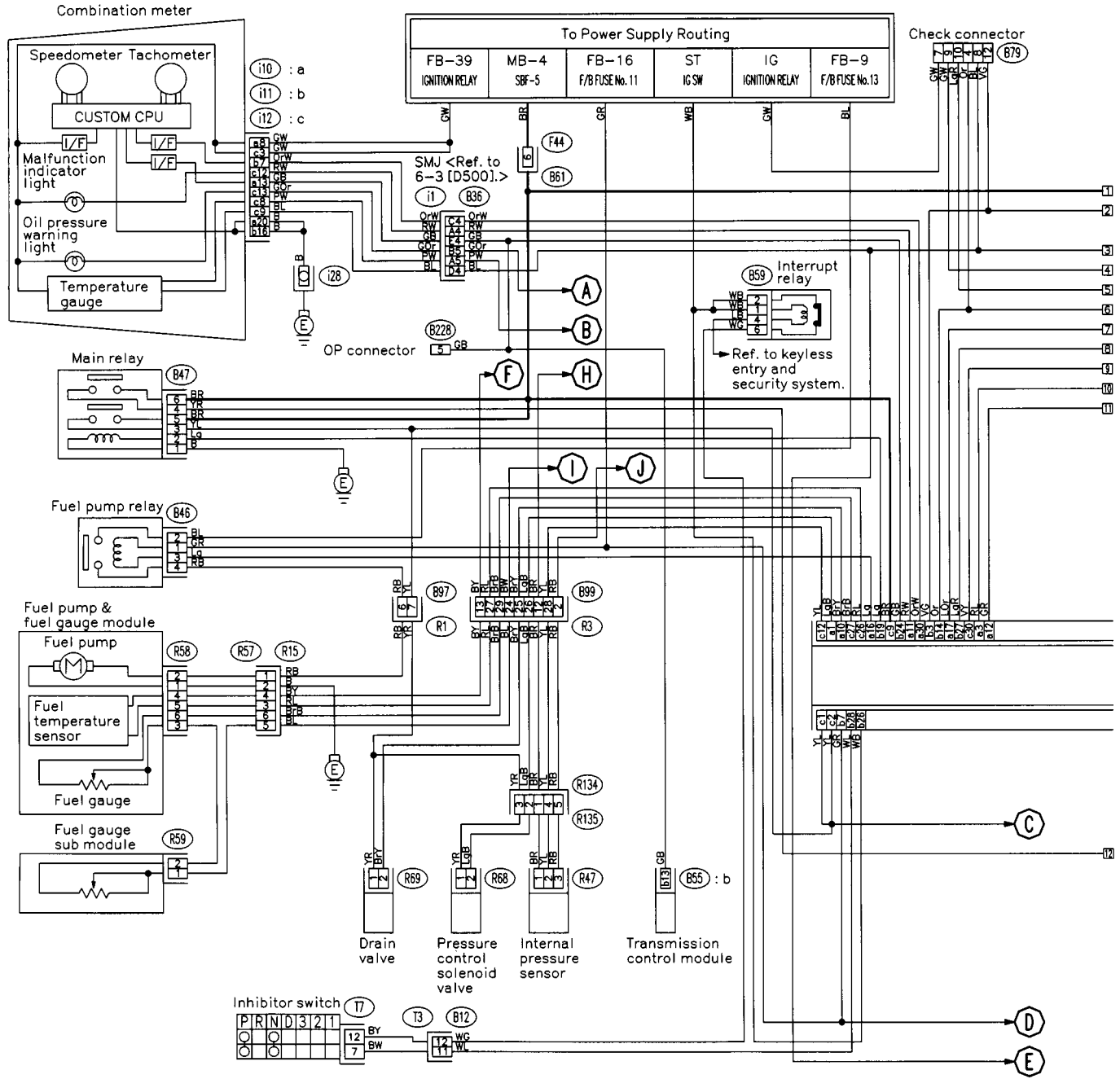

- (R59) (R47) (Black) (B46) (Green) (R135) (Gray) (R57) (Black) (R58) (Gray) (B59) (B47) (Brown) (17) (B79) (Gray) c: (i12) (Green)
- (R68) (Gray)
- (R69)

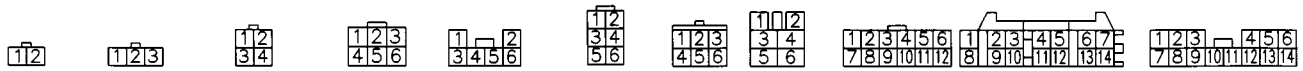

BU10-20A

- b: (i11) (Green) (B97) (B228) a: (i10) (Green) b: (B55) (Gray) (B12) (Black) (B99)
- (F44)

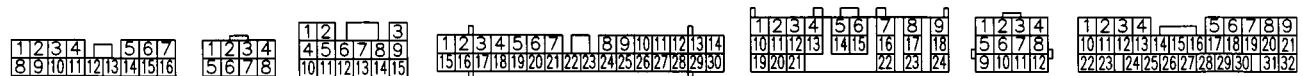

BU10-20A

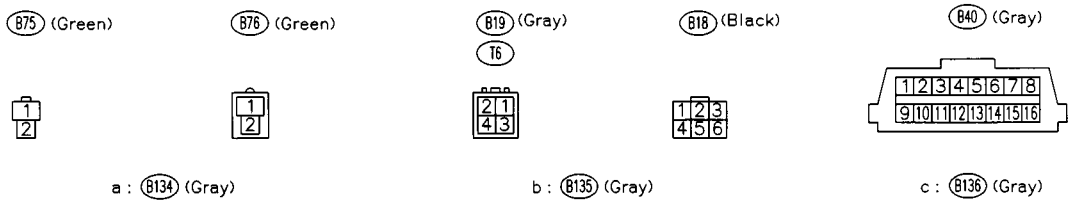
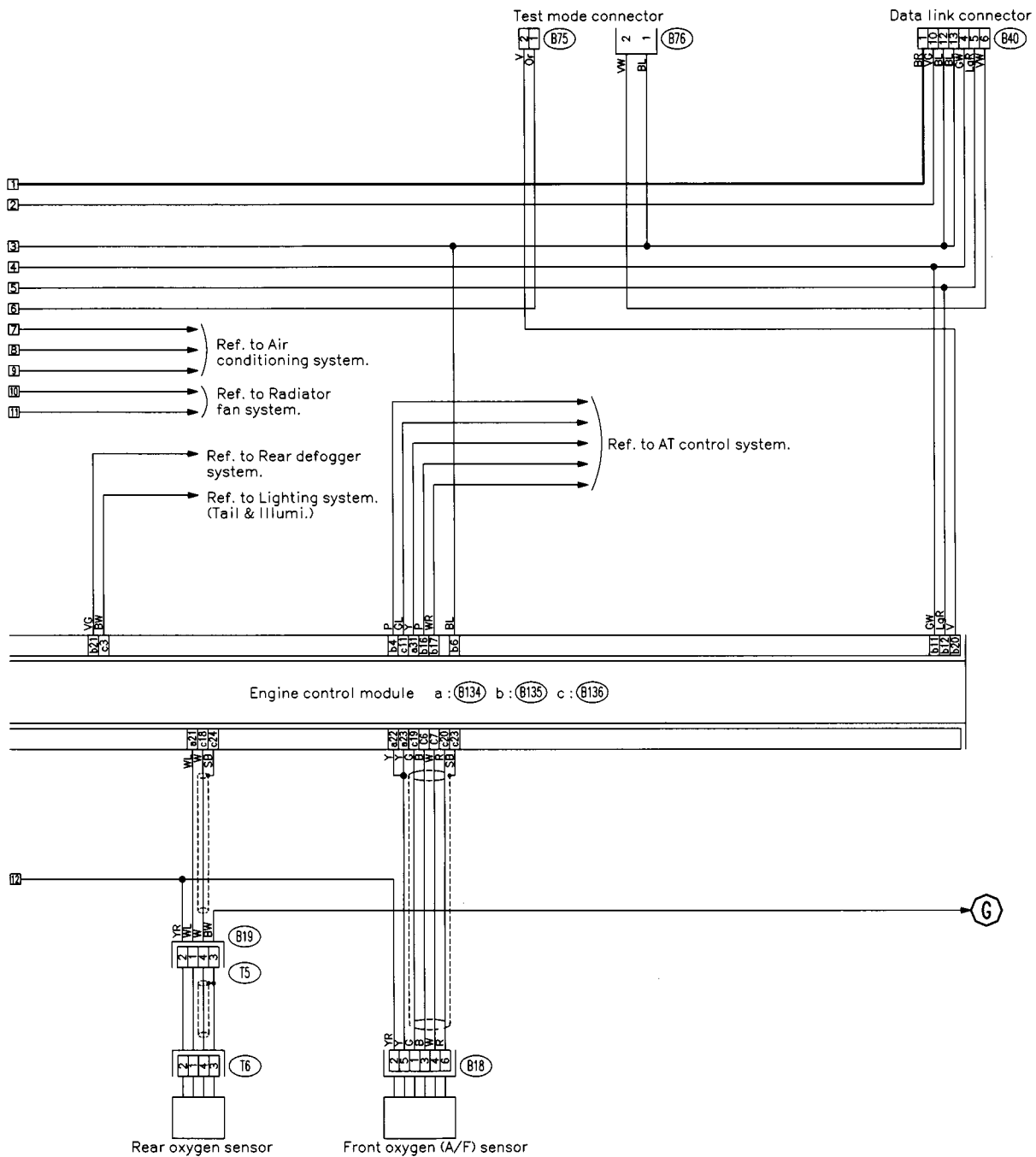

BU10-20B

1	2	3	4	5	6	7	8
9	10	11	12	13	14	15	16
17	18	19	20	21	22	23	24
25	26	27	28	29	30	31	32
33	34	35					

1	2	3	4	5	6	7
8	9	10	11	12	13	14
15	16	17	18	19	20	21
22	23	24	25	26	27	28

1	2	3	4	5	6	7	8
9	10	11	12	13	14	15	16
17	18	19	20	21	22	23	24
25	26	27	28	29	30		

BU10-20B

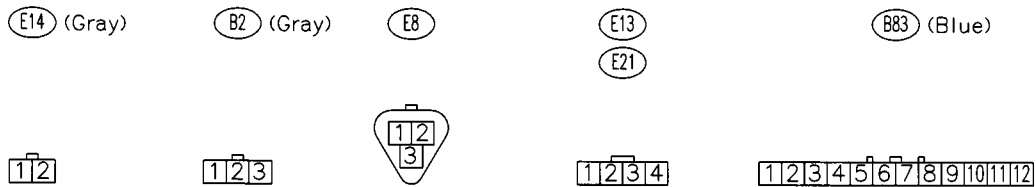
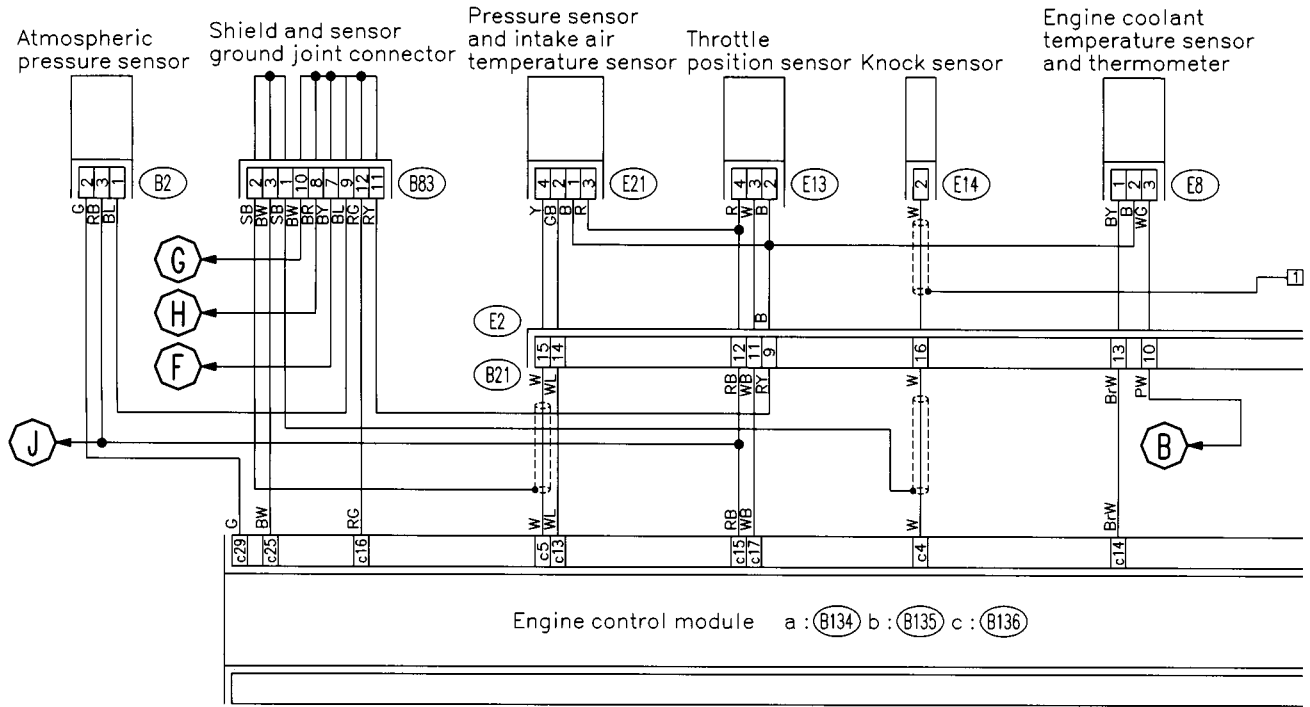

BU10-20C

BU10-20C

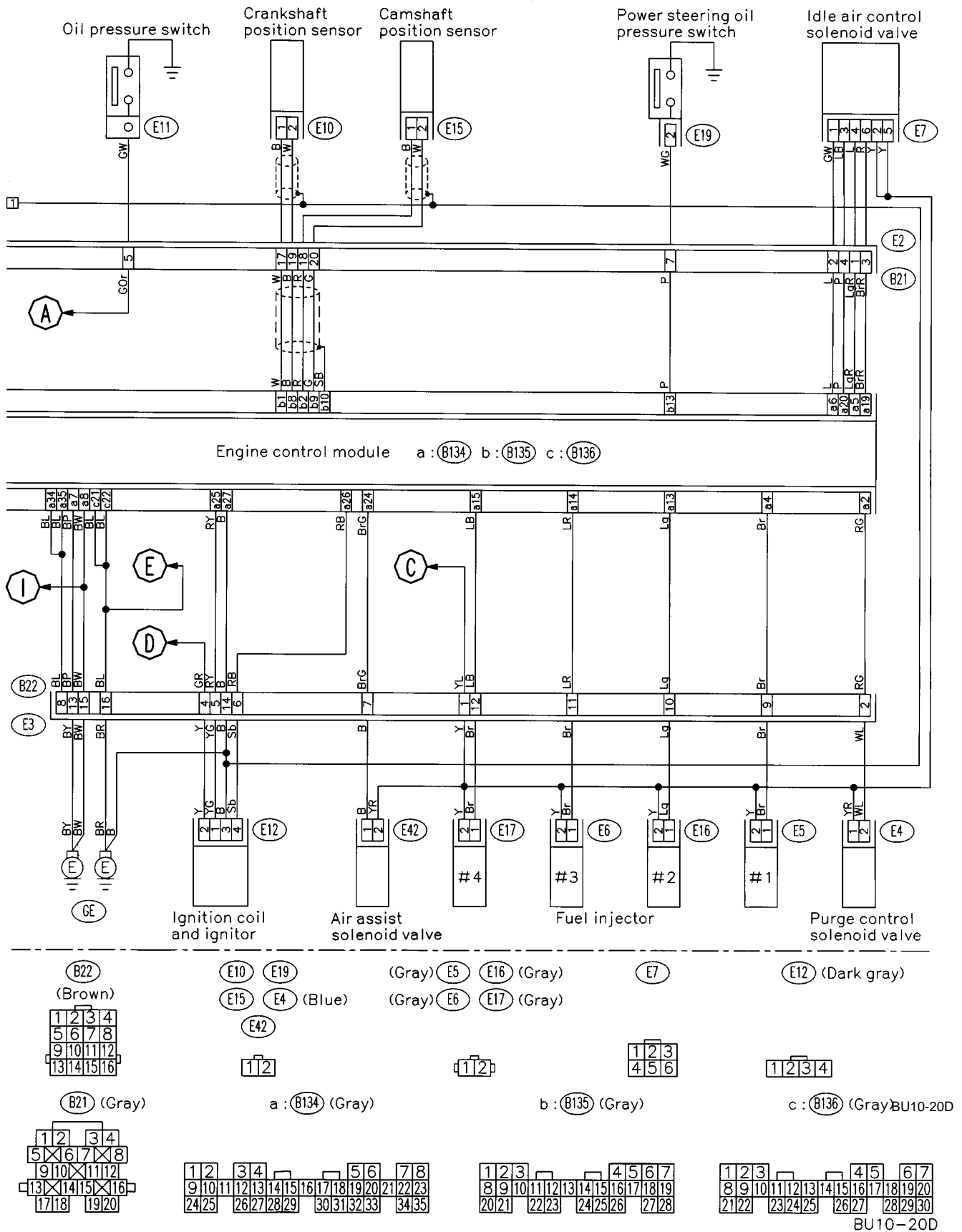

N: FUEL GAUGE SYSTEM

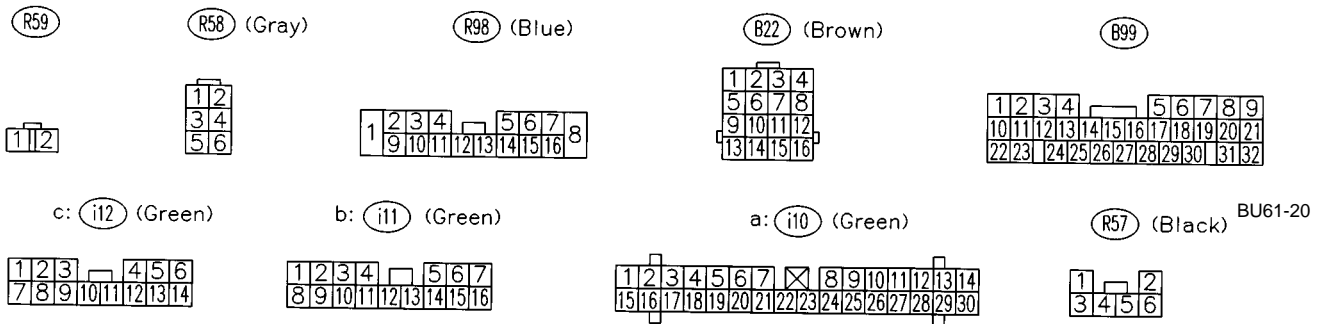
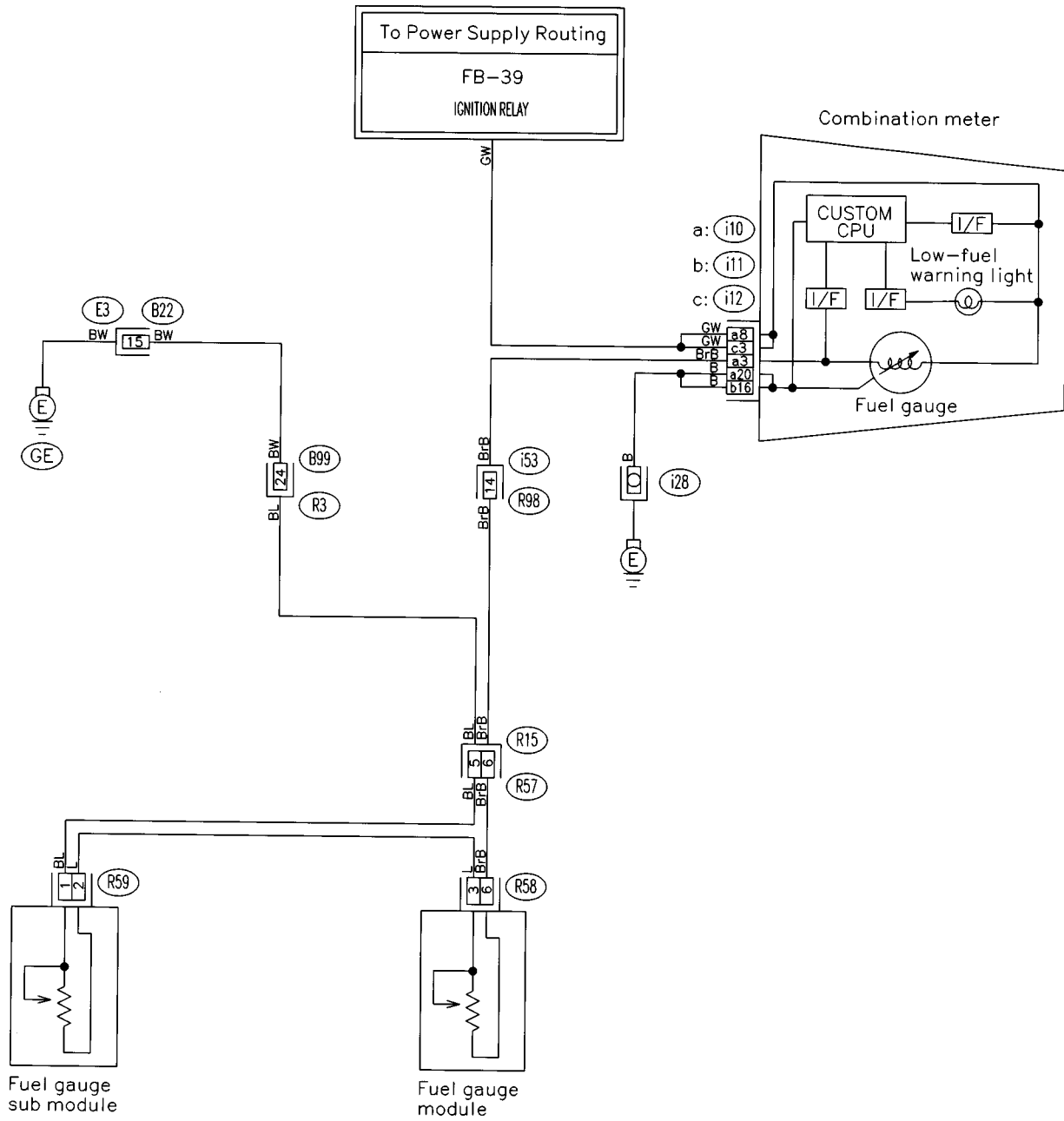

O: HORN AND FRONT ACCESSORY POWER SUPPLY SYSTEM

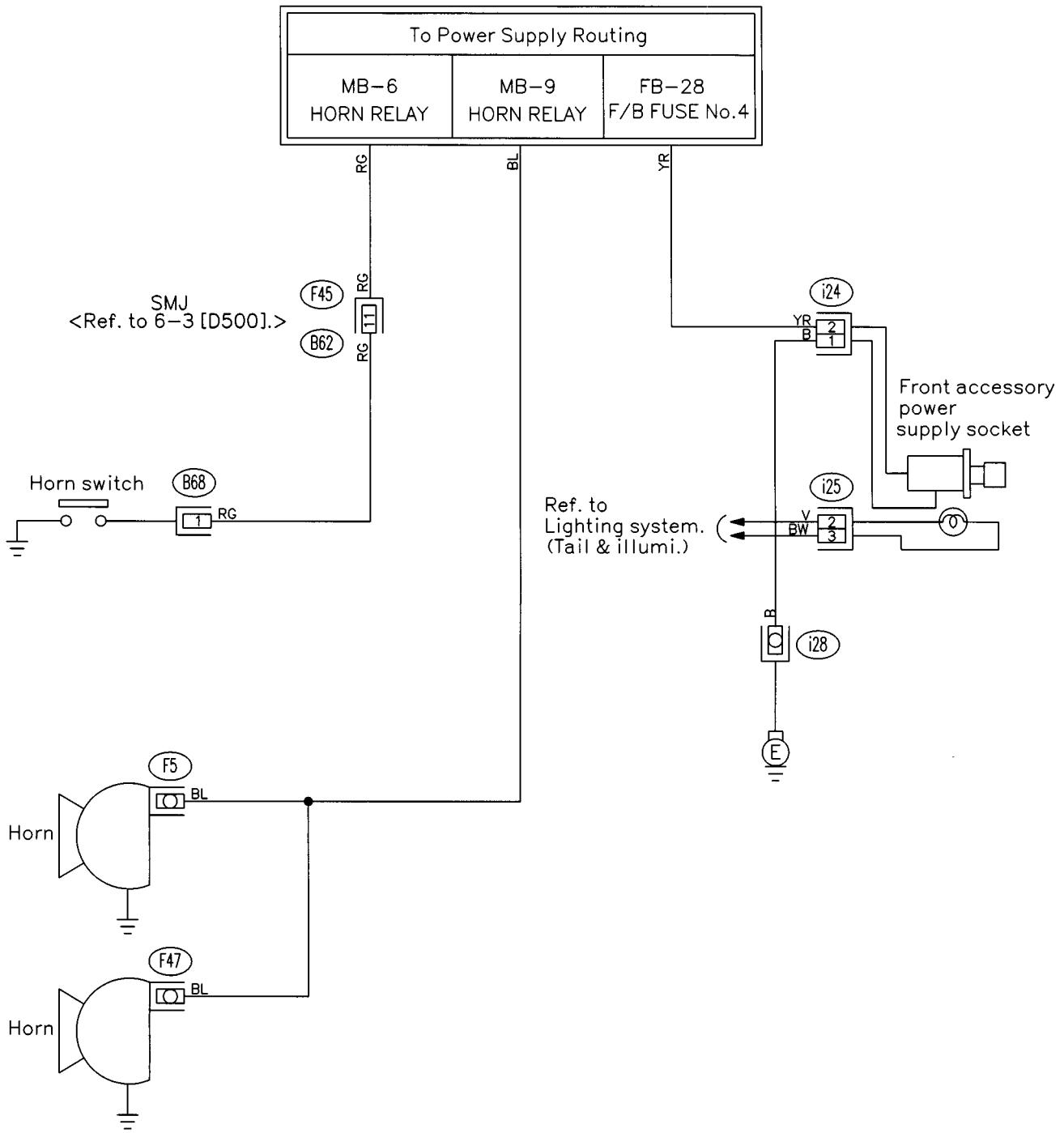

BU74-20

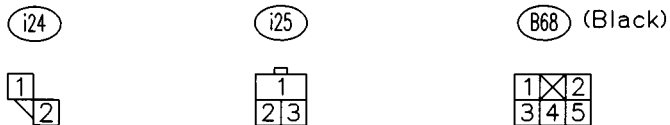

BU74-20

P: KEYLESS ENTRY AND SECURITY SYSTEM

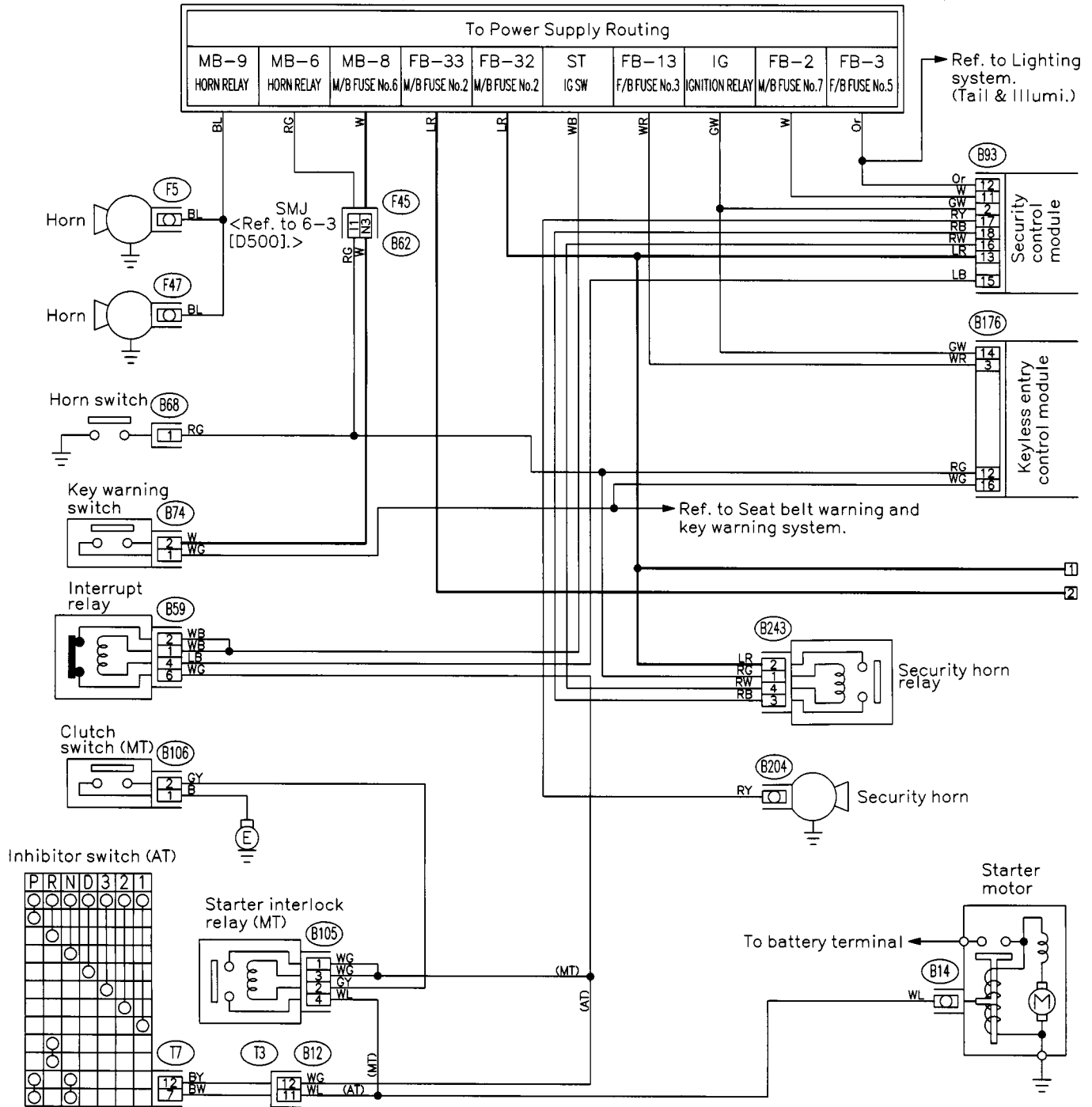

(B68) (Black)



(B106)

(B74) (Black)



(B105) (Blue)



(B12)

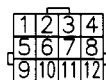

(T7)

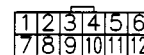

BU94-20A

(B176)

(07)

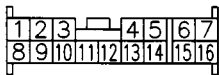

(B93)

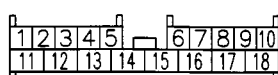

(B59)

(B243)



(B99)

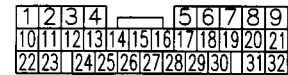

BU94-20A

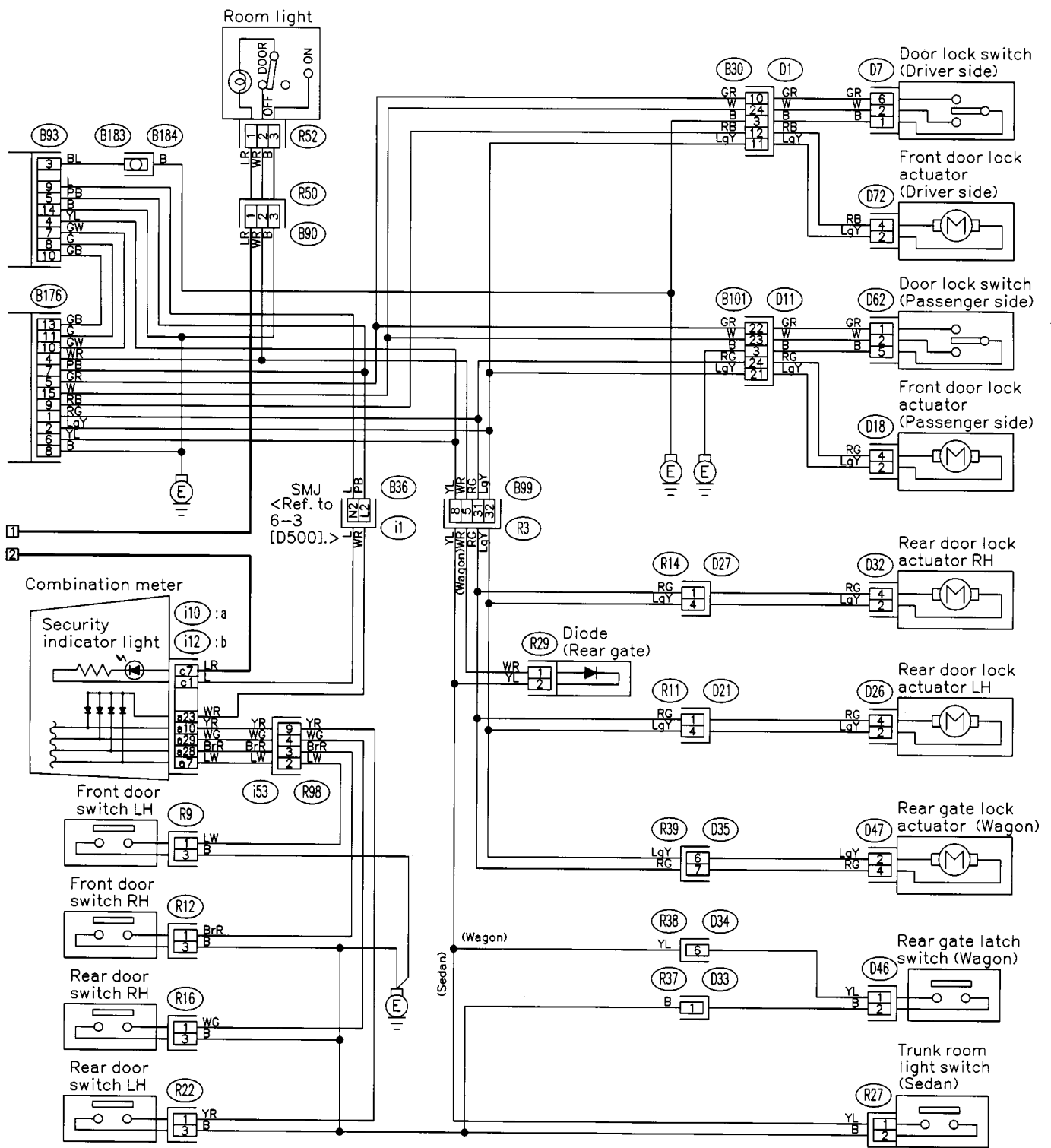

<p>R27</p> <p>R16 (Black)</p> <p>R22 (Black)</p>	<p>R29</p> <p>R9</p> <p>R12</p>	<p>R37</p> <p>D46 (Black)</p> <p>D18</p> <p>D26</p> <p>D32</p> <p>D47</p> <p>D72</p>	<p>R52</p> <p>R14</p> <p>R11</p> <p>D35 (Black)</p> <p>D34</p>	<p>D62 (Brown)</p> <p>B90</p> <p>B101</p> <p>B30</p>	<p>c: i12 (Green)</p> <p>a: i10 (Green)</p>	<p>R98 (Blue)</p>
--	---------------------------------	--	--	--	---	-------------------

BU94-20B

Q: LIGHTING SYSTEM (BACK-UP LIGHT)

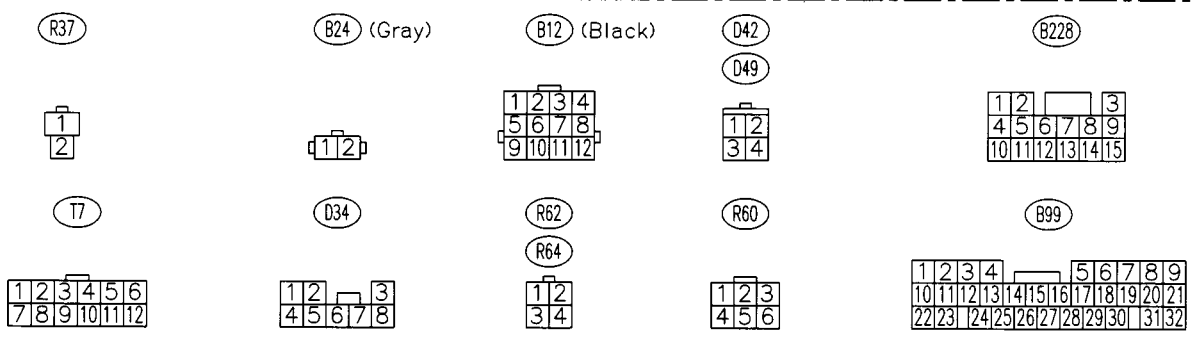
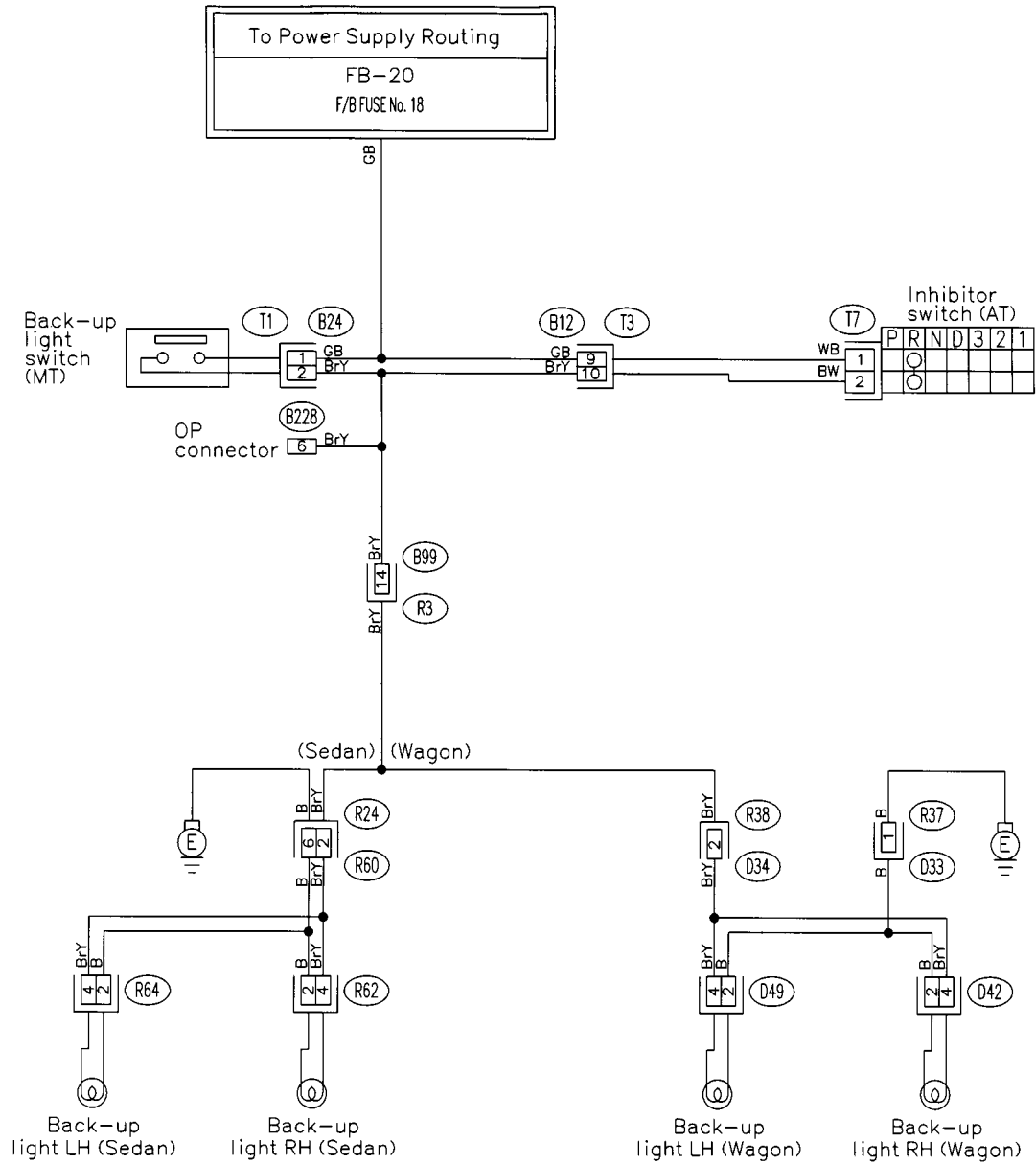

BU29-20

BU29-20

MEMO:

R: LIGHTING SYSTEM (CLEARANCE LIGHT AND ILLUMINATION LIGHT)

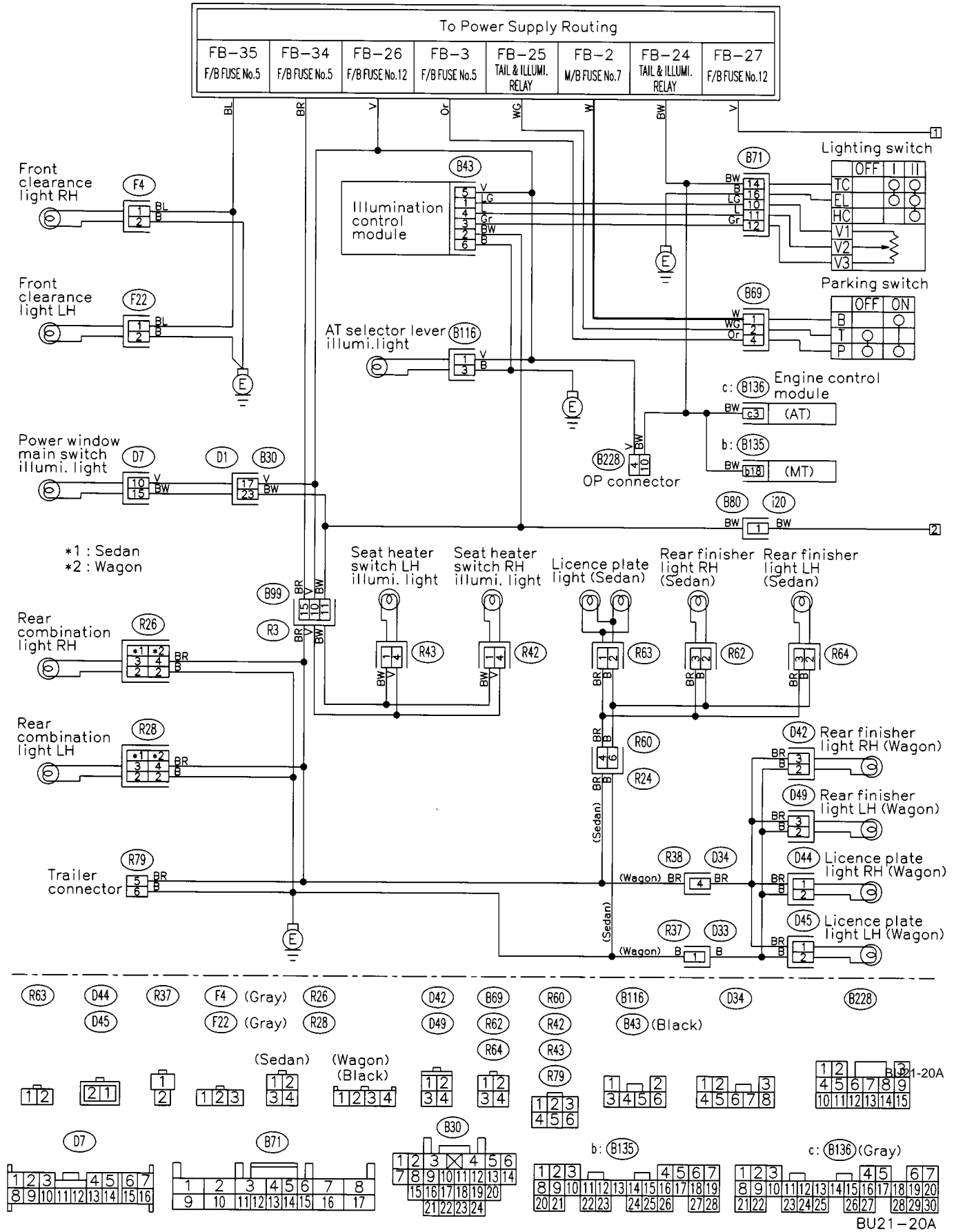

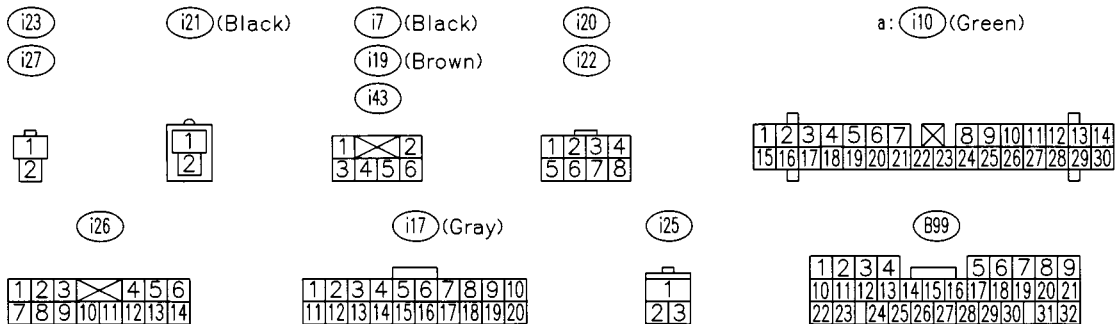
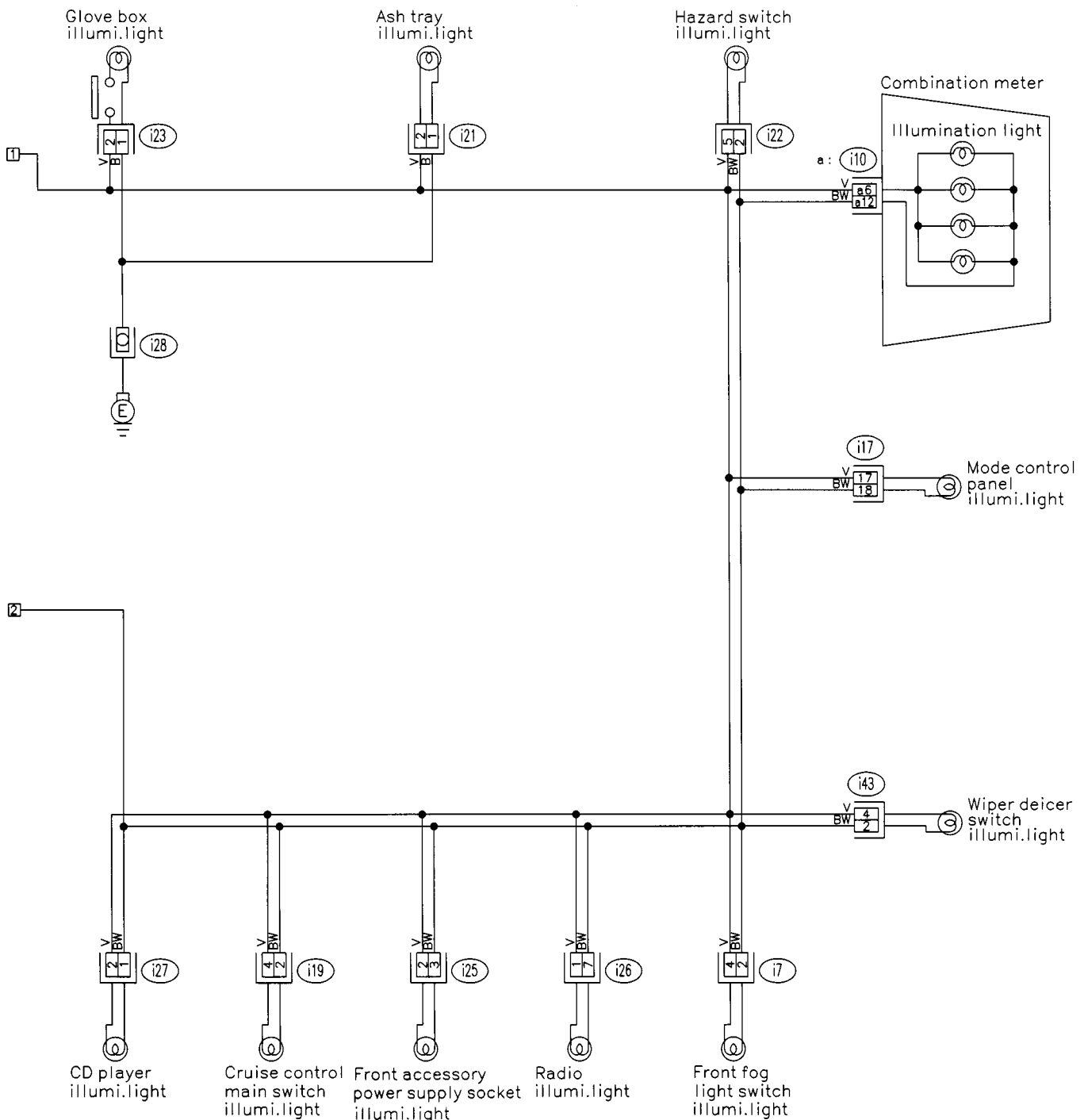

BU21-20B

BU21-20B

S: LIGHTING SYSTEM (FRONT FOG LIGHT)

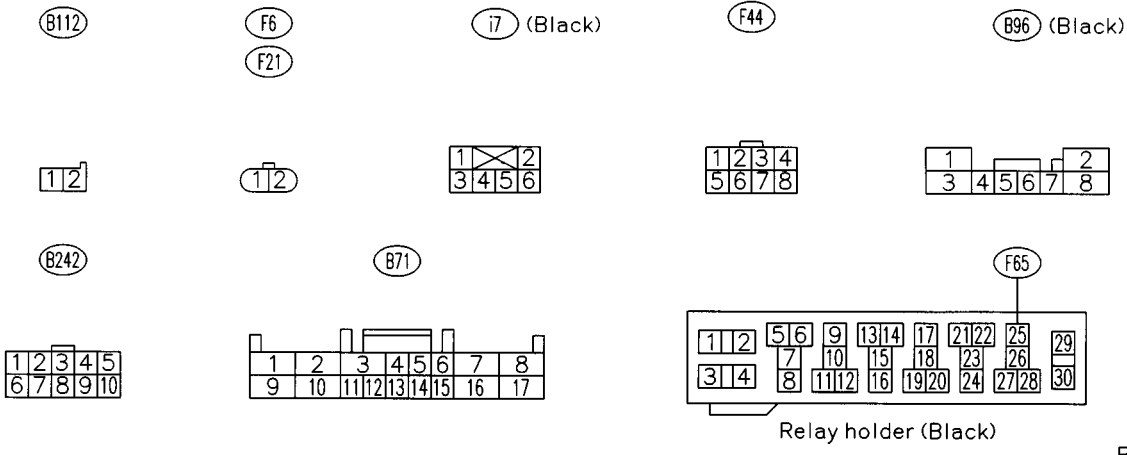
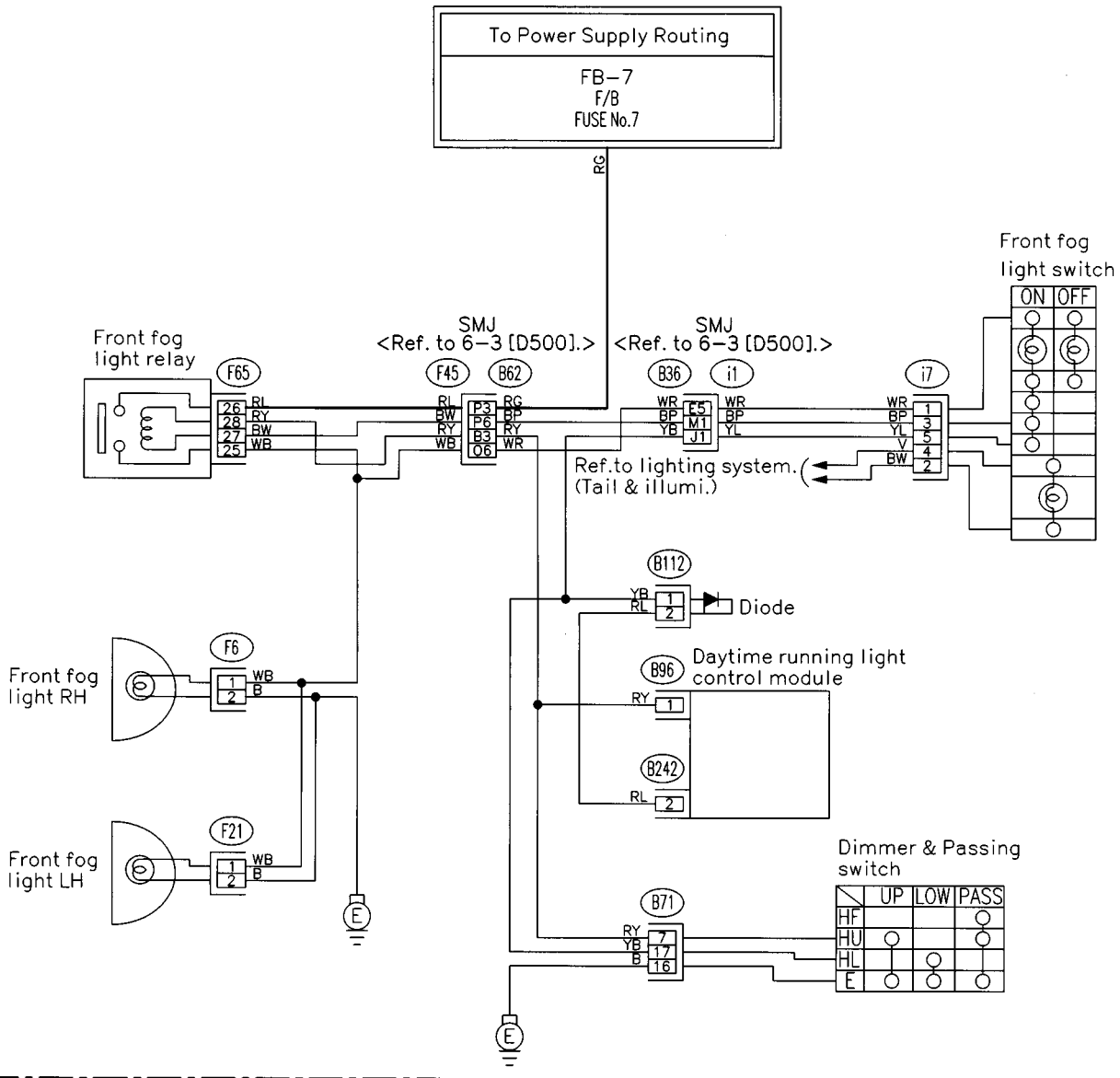

T: LIGHTING SYSTEM (HEADLIGHT)

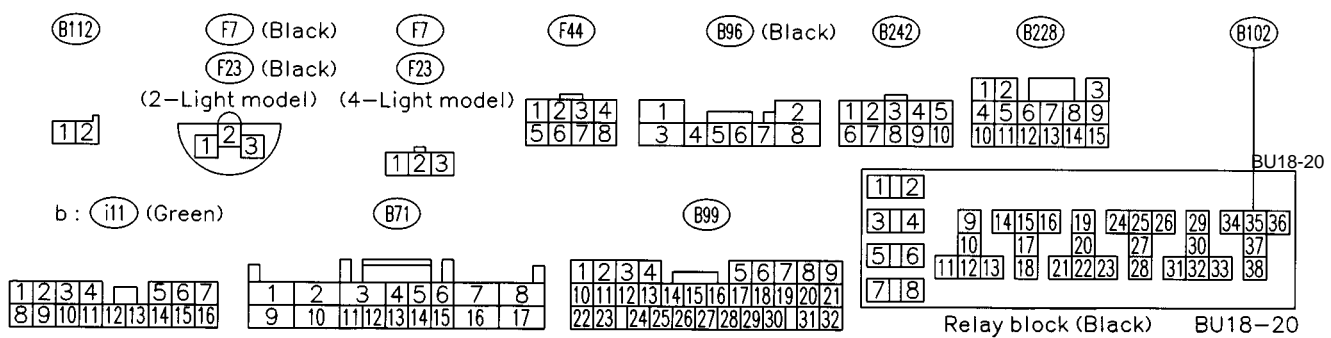
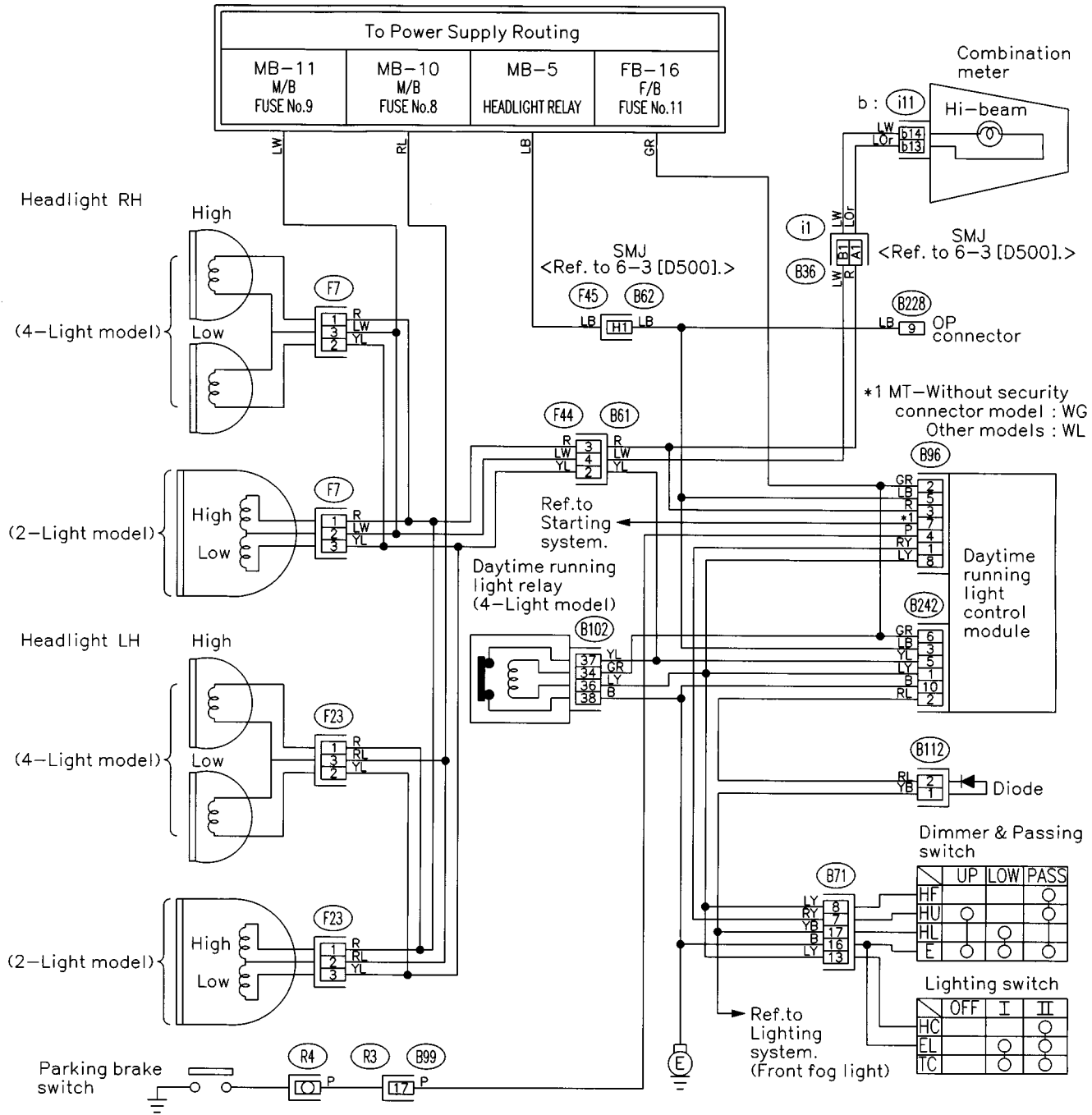

U: LIGHTING SYSTEM (IN COMPARTMENT)

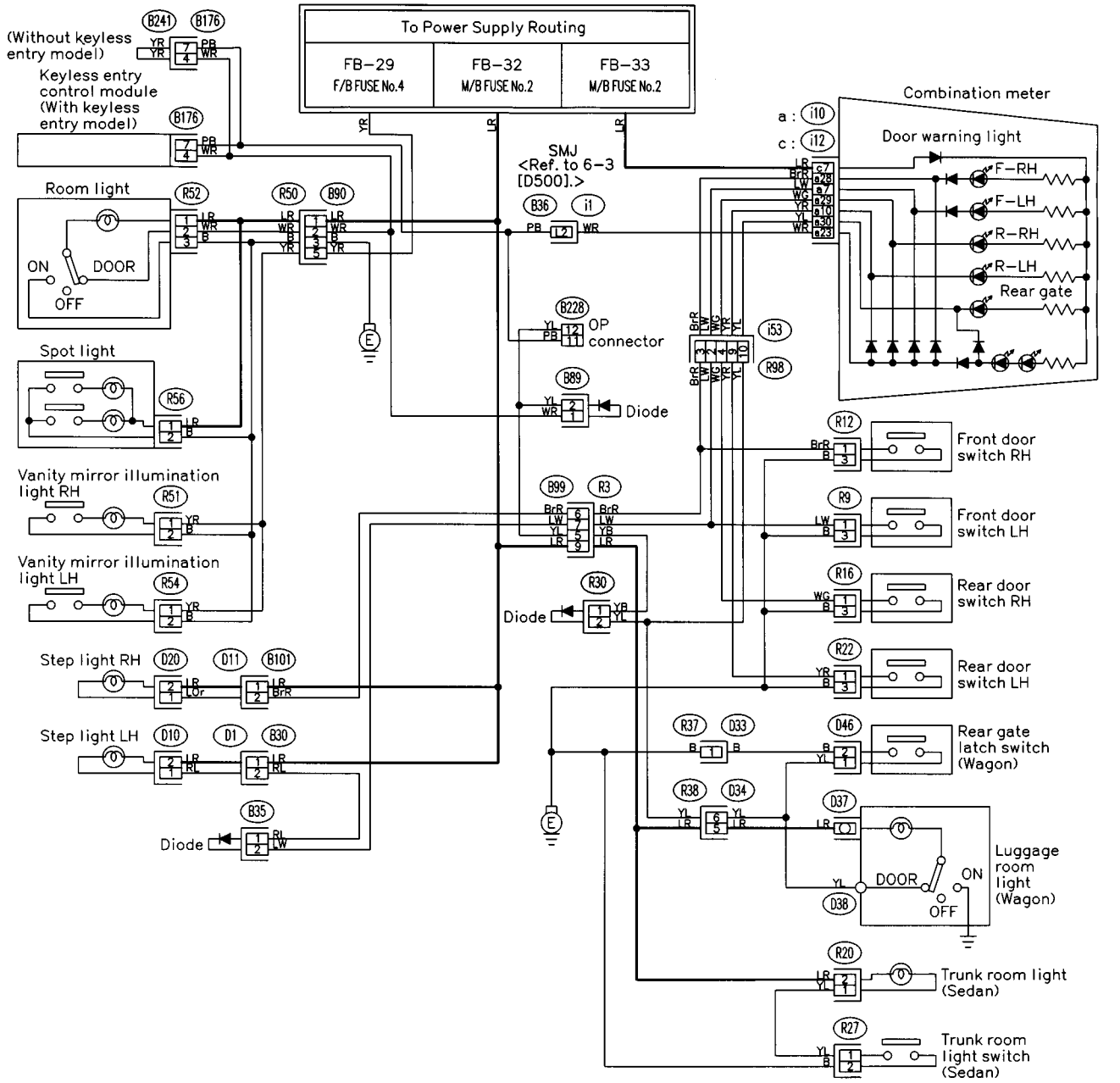

- (B176)
- (D10)
- (D20)
- (R30) (Black)
- (R27)
- (R37)
- (D46) (Black)
- (R52)
- (R12)
- (R22) (Black)
- (R90)
- (D34)
- c : (i12) (Green)
- (R89)
- (R51)
- (R54)
- (R20) (Blue)
- (R9)
- (R16) (Black)

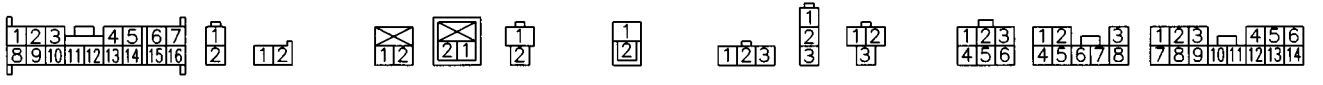

- (B228)
- (R98) (Blue)
- (B30)
- (B101)
- a : (i10) (Green)
- (R89)
- BU23-20

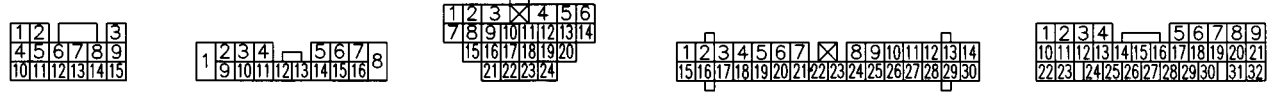

V: LIGHTING SYSTEM (STOP LIGHT)

1. SEDAN MODEL

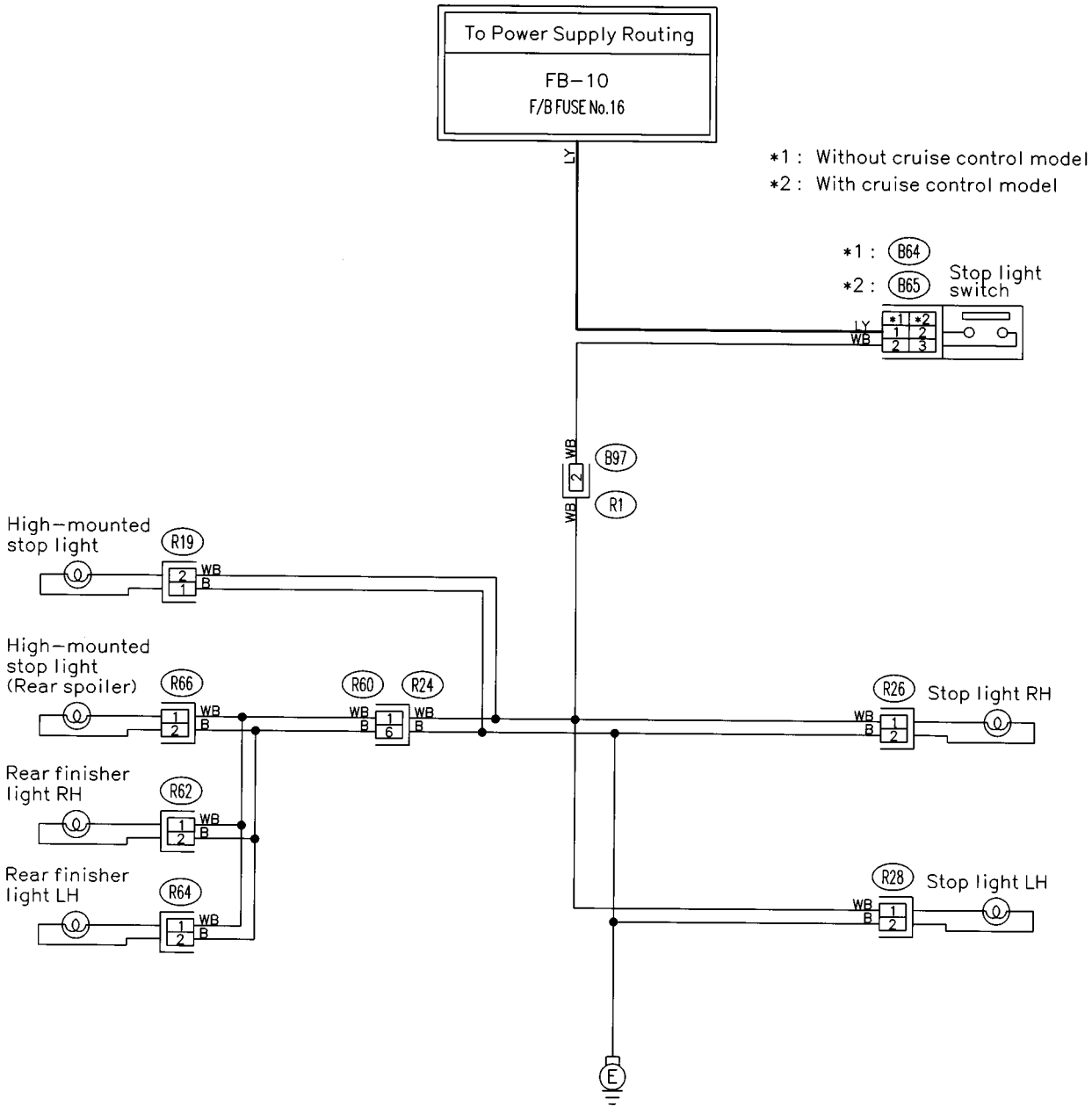

(R19)



(B64) (Black)



(R66)



(R60)



(B65) (Black)



(B97)



(R26) (R62)

(R28) (R64)



BU25-21

BU25-21

2. WAGON MODEL

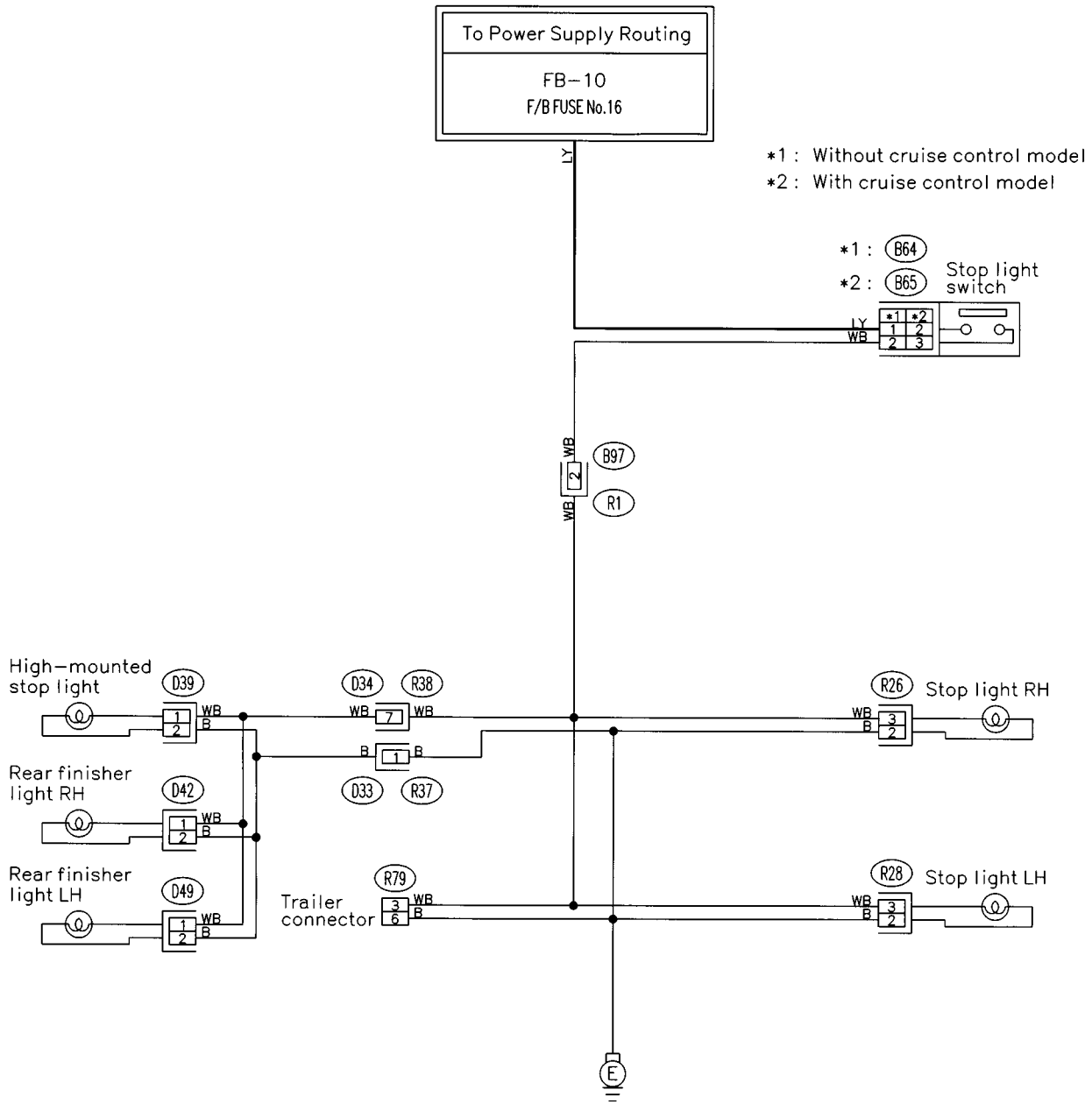

*1 : Without cruise control model
*2 : With cruise control model

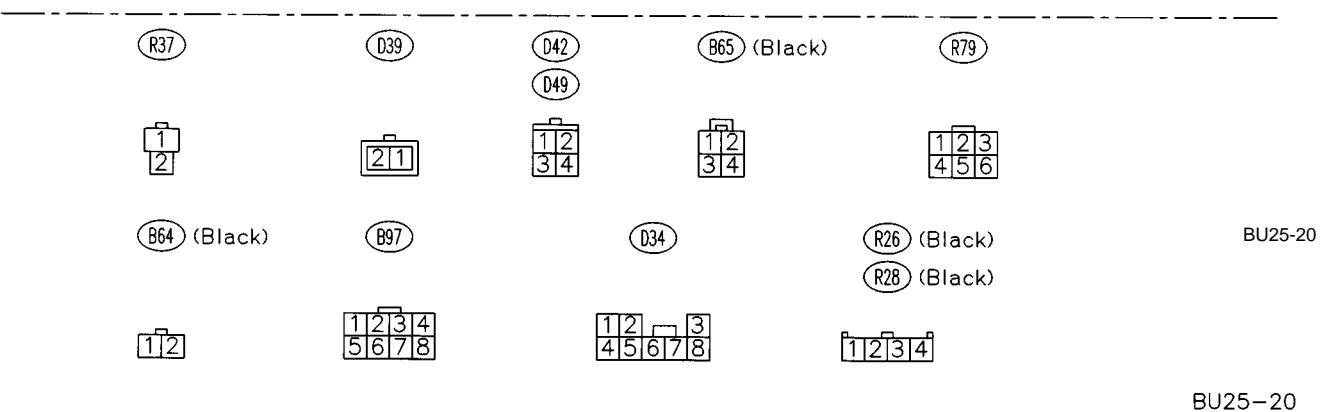
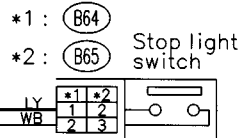

BU25-20

W: LIGHTING SYSTEM (TURN SIGNAL LIGHT AND HAZARD LIGHT)

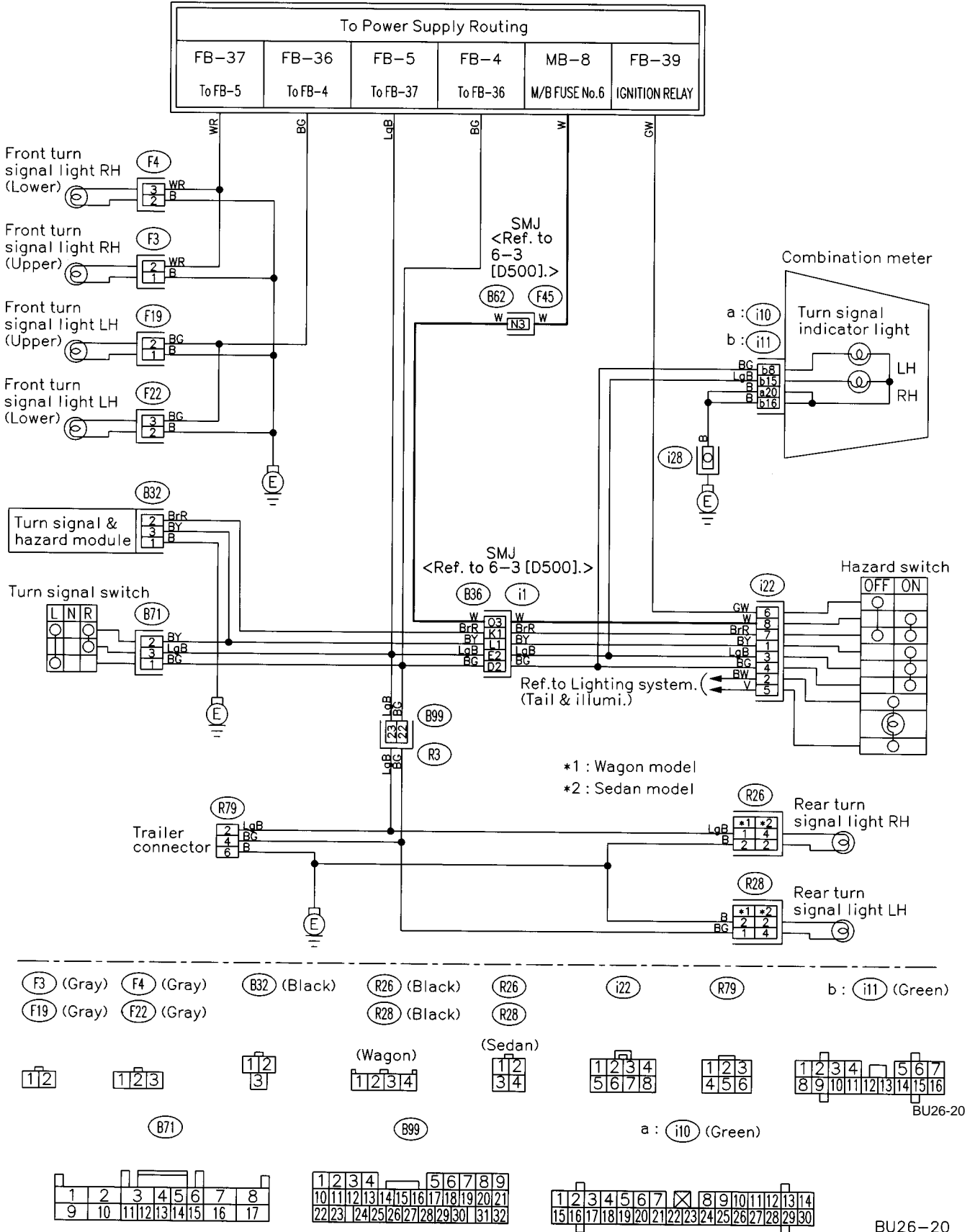

X: MULTIPLE POWER SOCKET SYSTEM (OPTION)

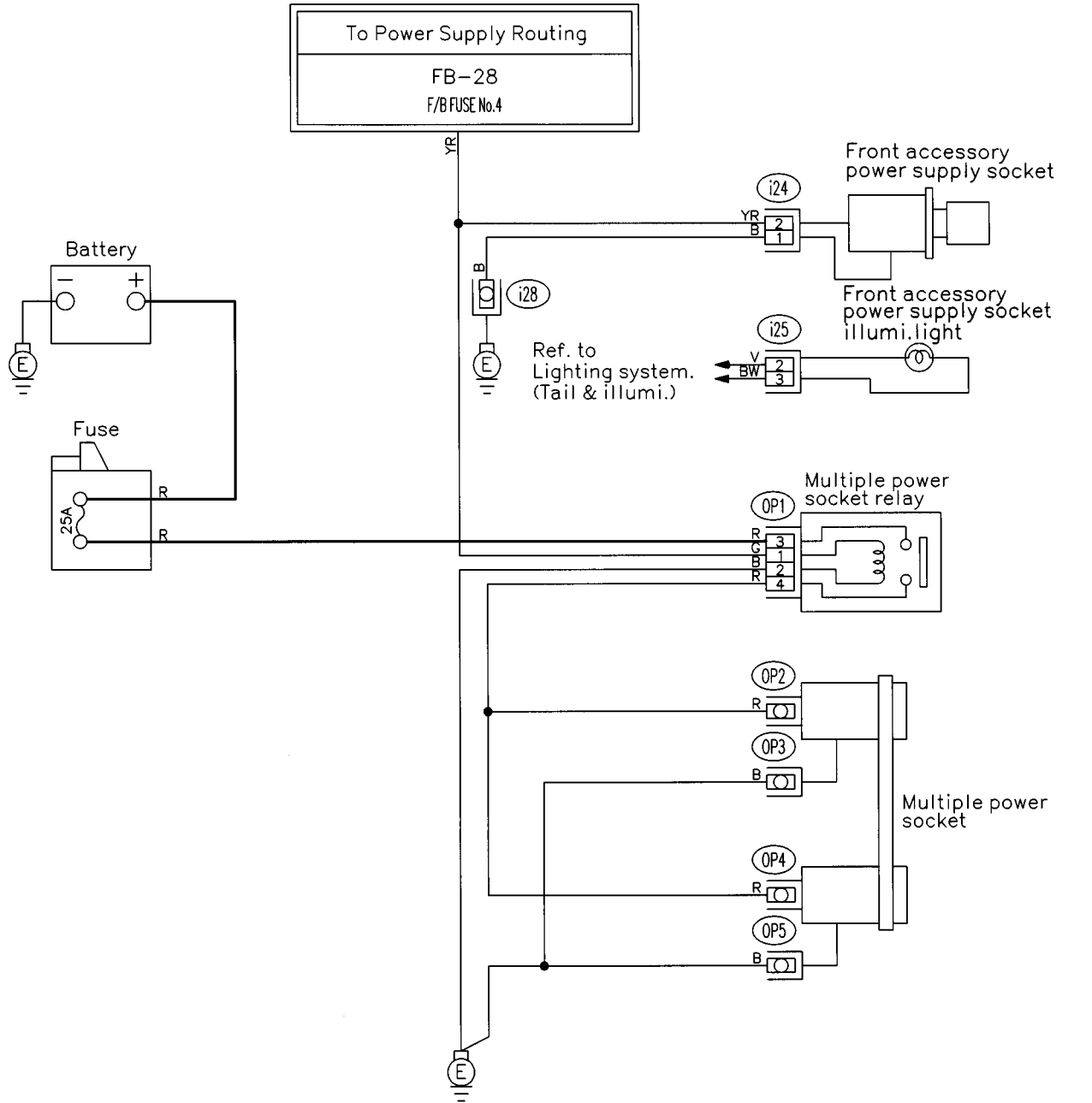

Y: OIL PRESSURE AND TEMPERATURE GAUGE SYSTEM

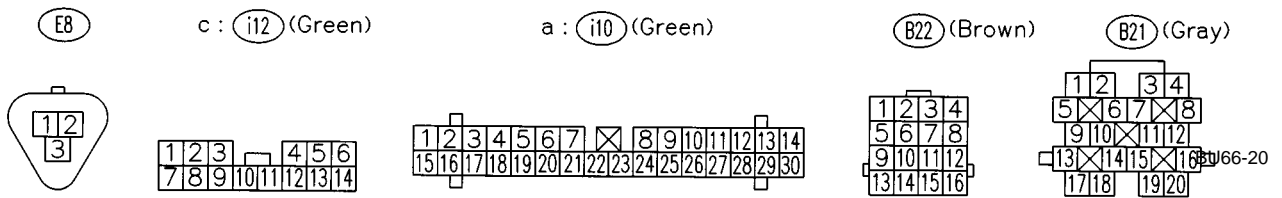
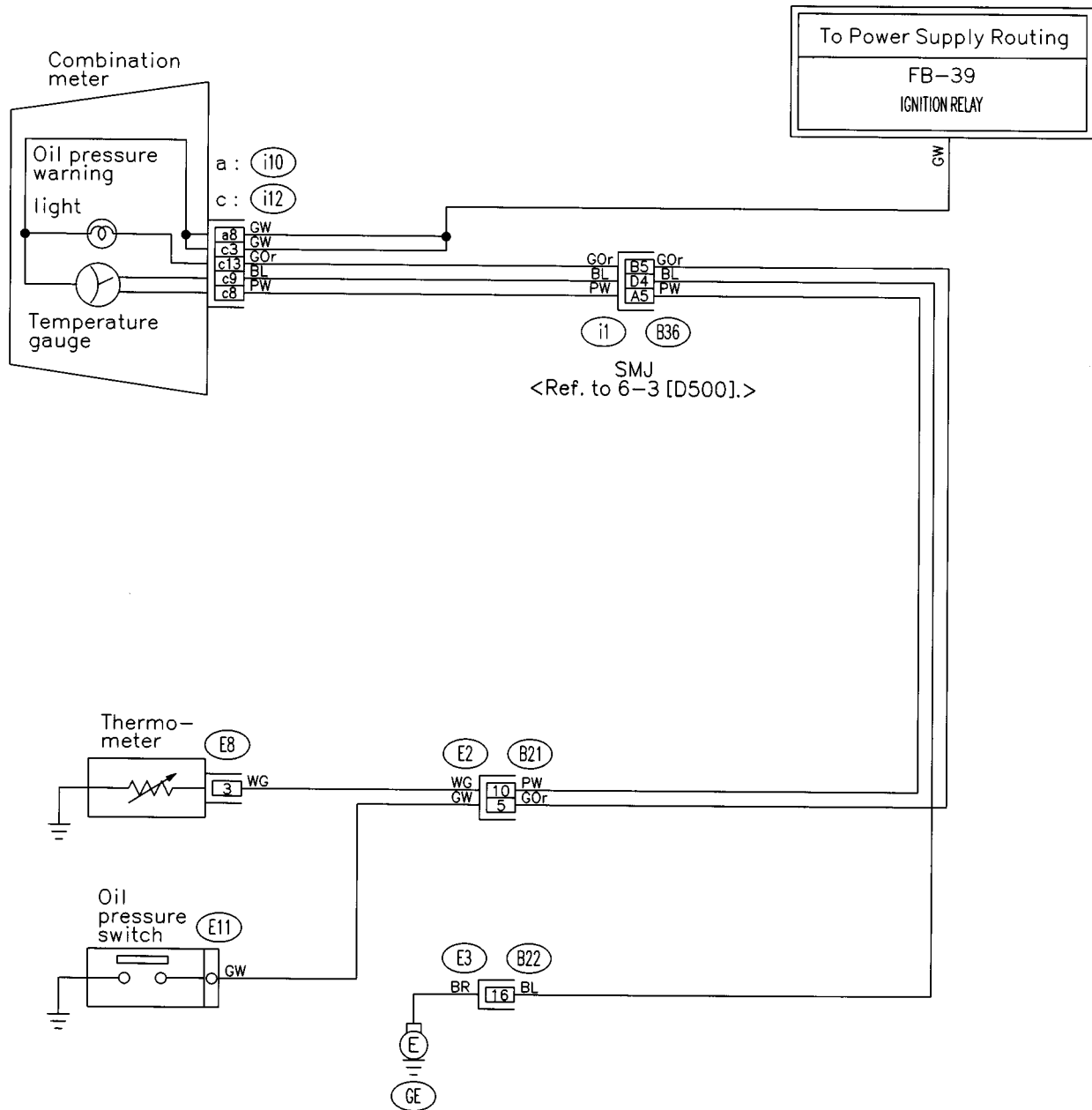

BU66-20

Z: PARKING BRAKE AND BRAKE FLUID LEVEL WARNING SYSTEM

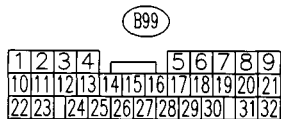
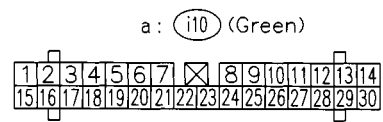
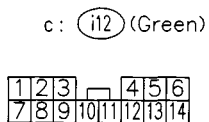
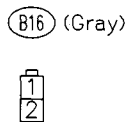
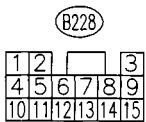
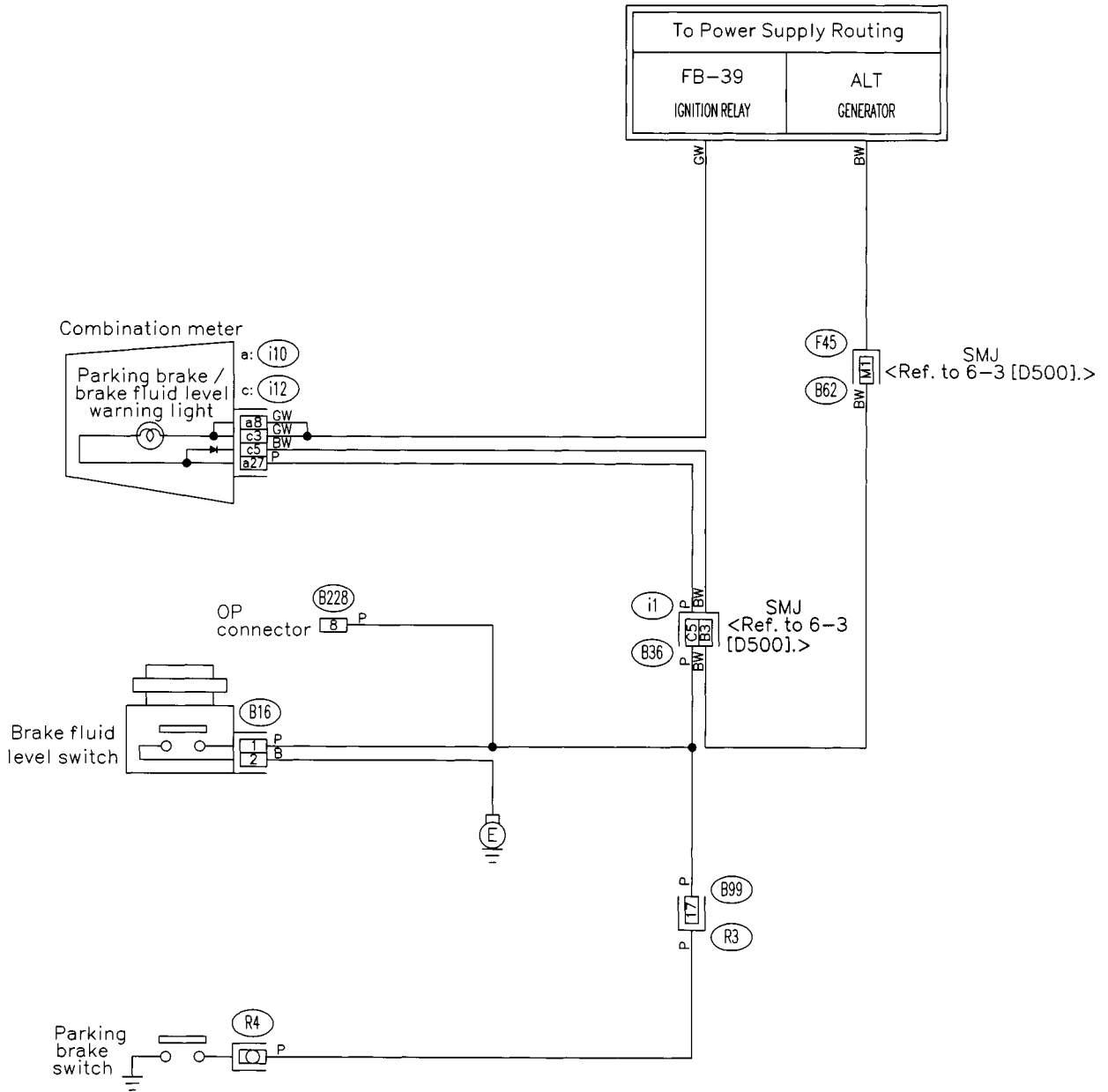

BU60-20

BU60-20

AA: POWER SEAT SYSTEM

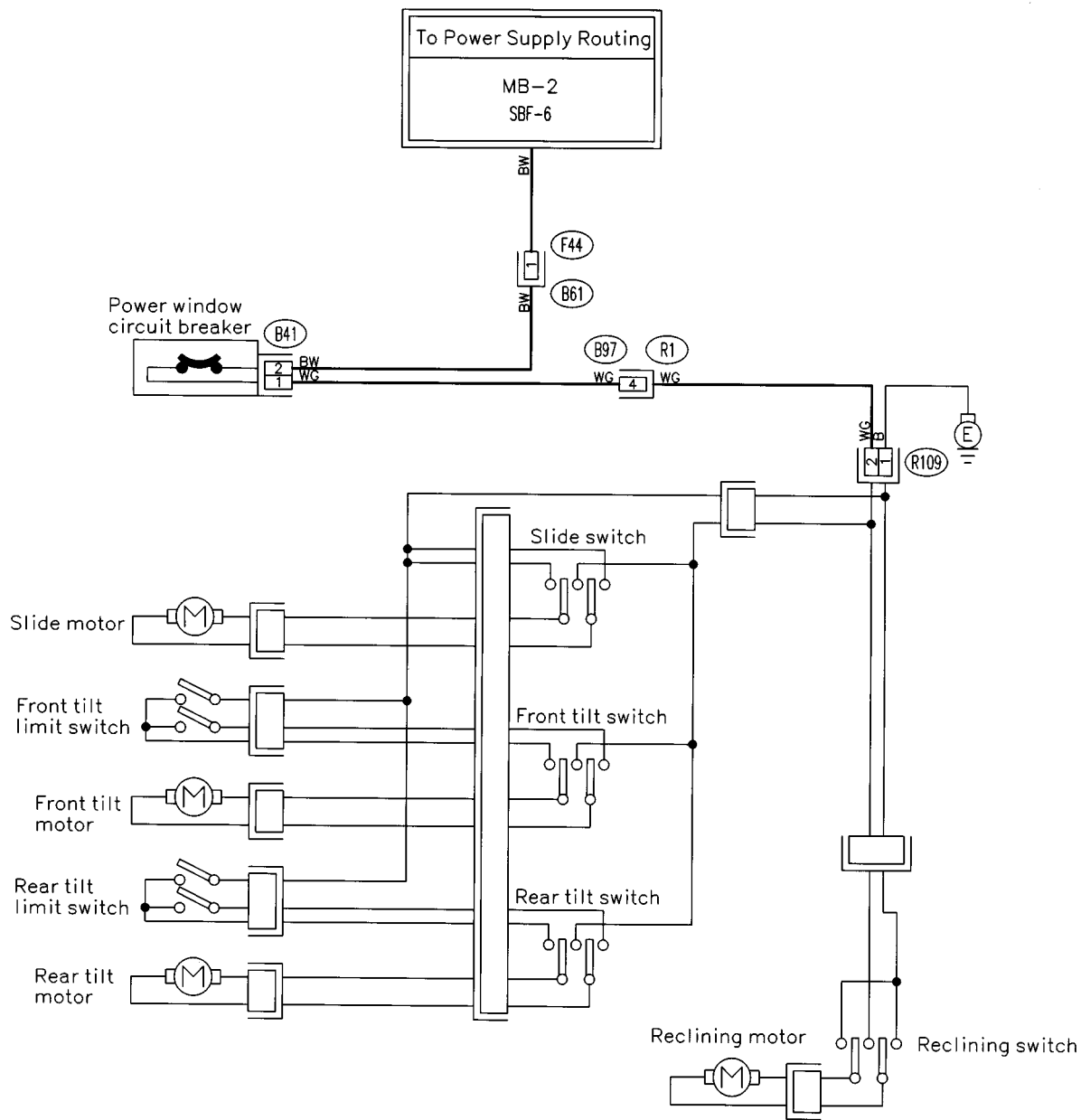

B41

R109 (Black)

F44

B97

BU85-20



BU85-20

AB: POWER WINDOW SYSTEM

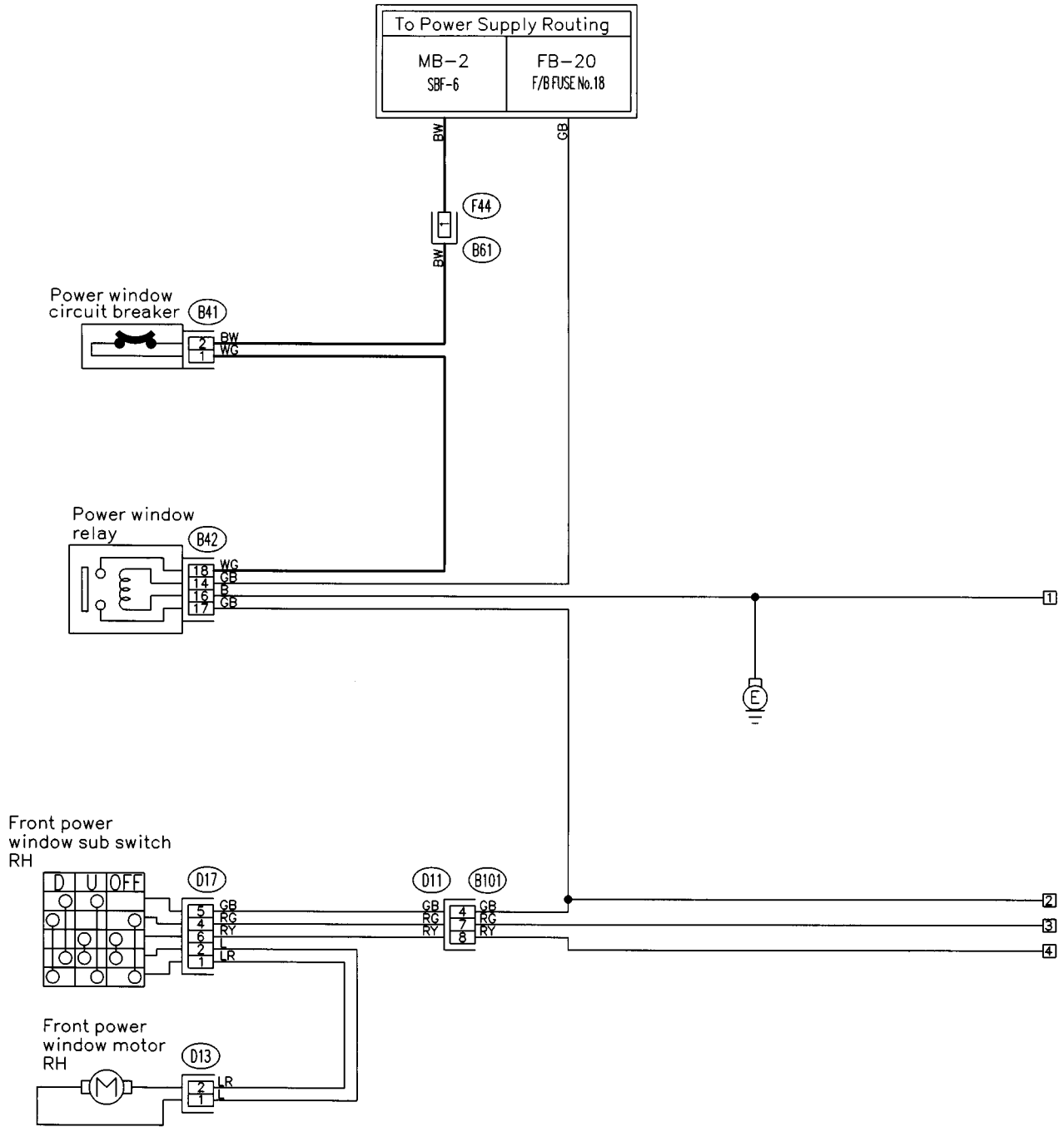

(B41)
(D13) (Green)

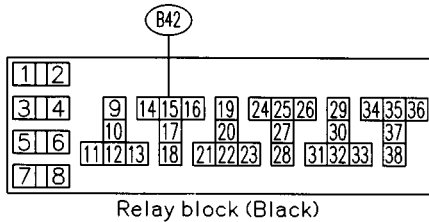

(D17)



(F44)
(B97) BU70-20A

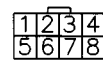

BU70-20A

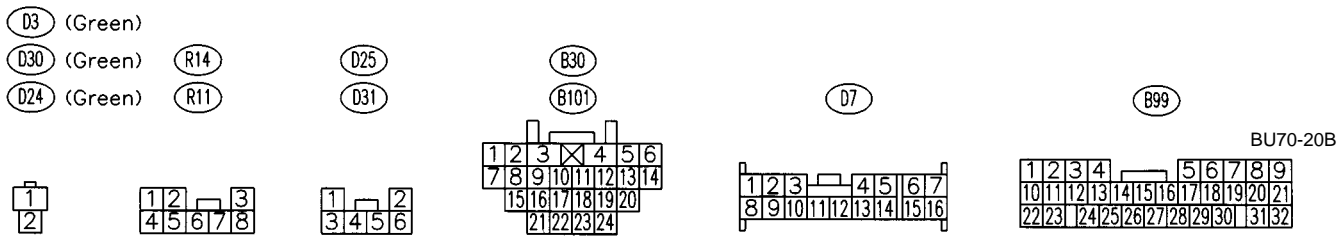
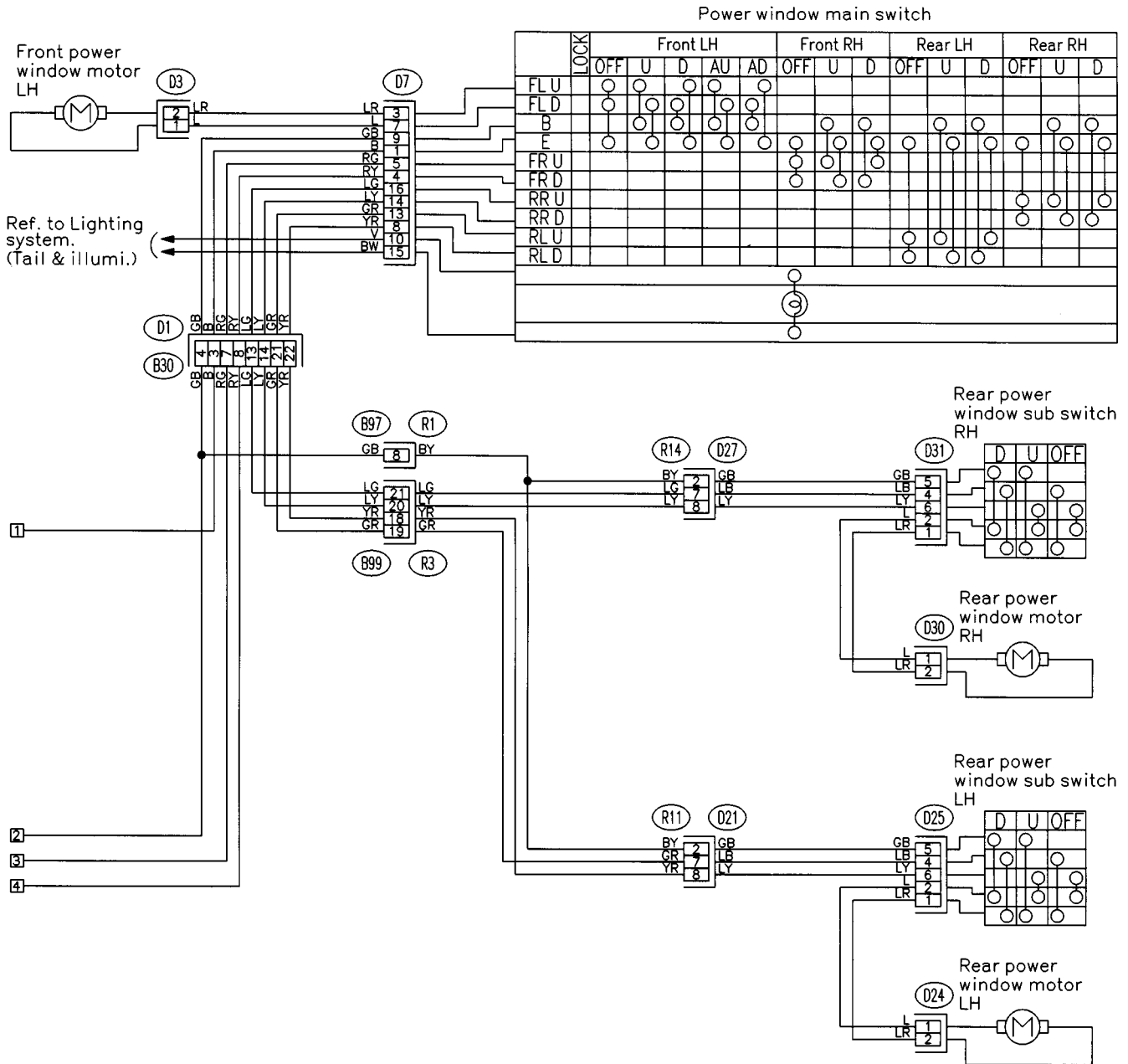

BU70-20B

AC: RADIATOR FAN SYSTEM

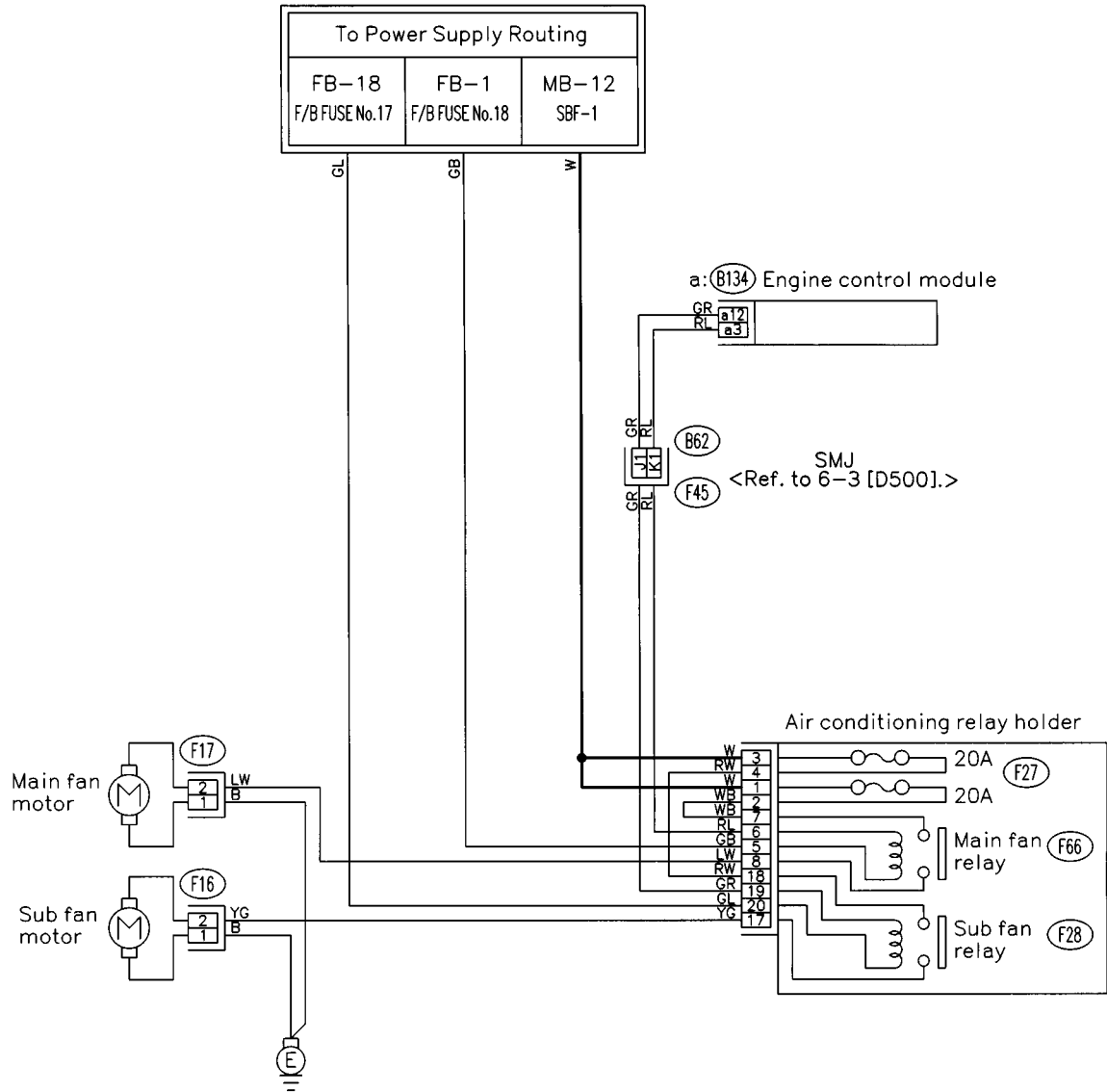

*1 AT : Gray
MT : Non-colored

F16 (Black)
F17 (Black)

F27 F66 F28

a : B134 (*1)

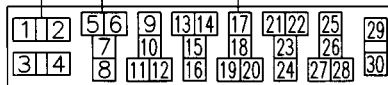

Relay holder (Black)

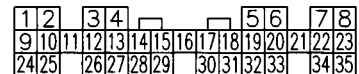

BU14-20

BU14-20

AD: REAR ACCESSORY POWER SUPPLY SYSTEM

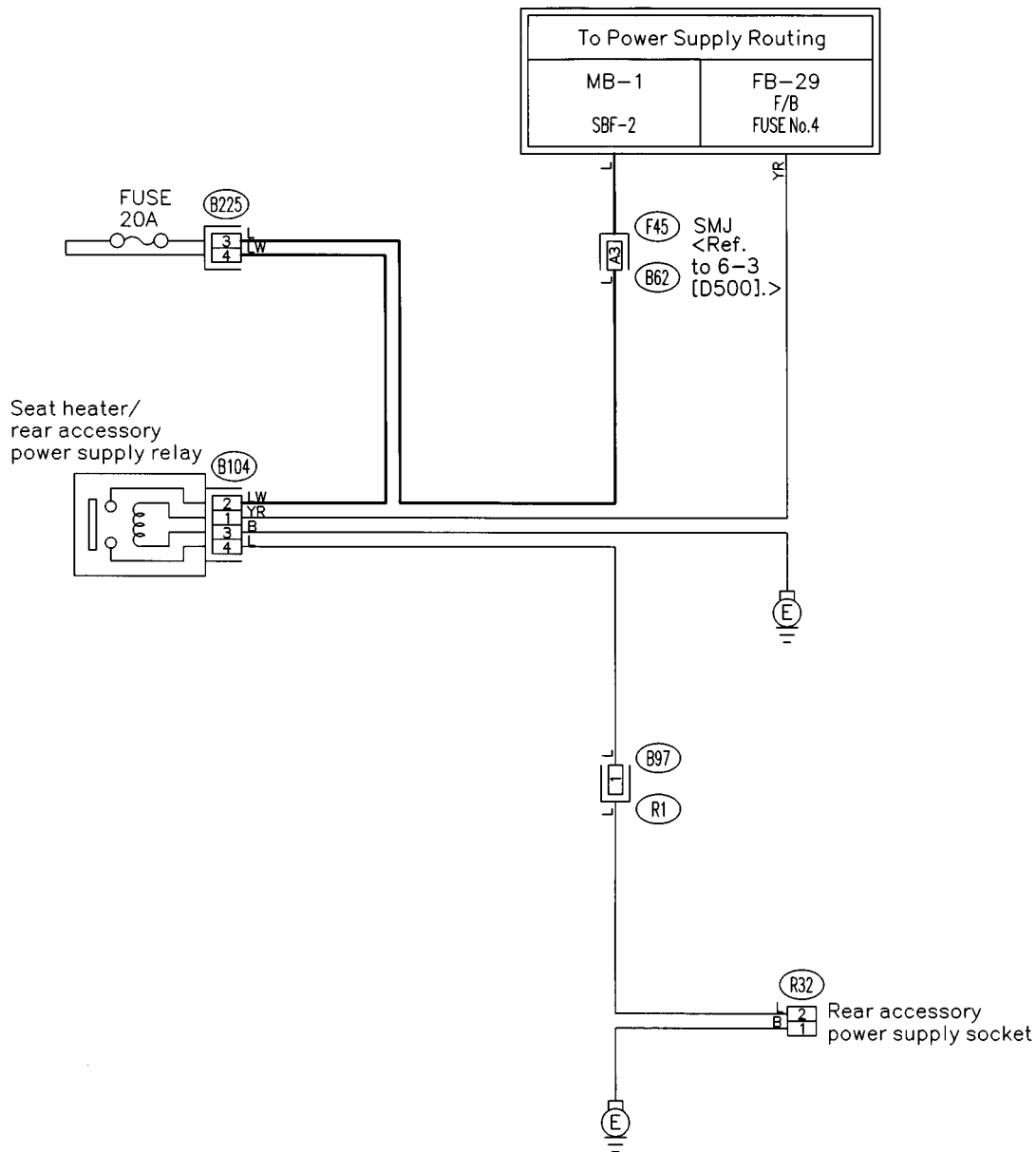

(R32)

(B104)

(B97)

(B225)

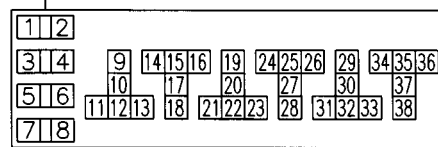
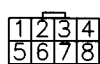

BU90-20

Relay block (Black)

BU90-20

AE: REAR WINDOW DEFOGGER SYSTEM

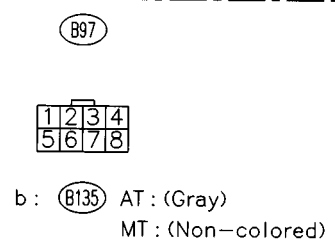
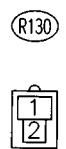
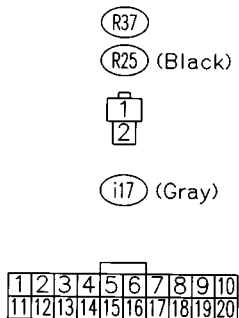
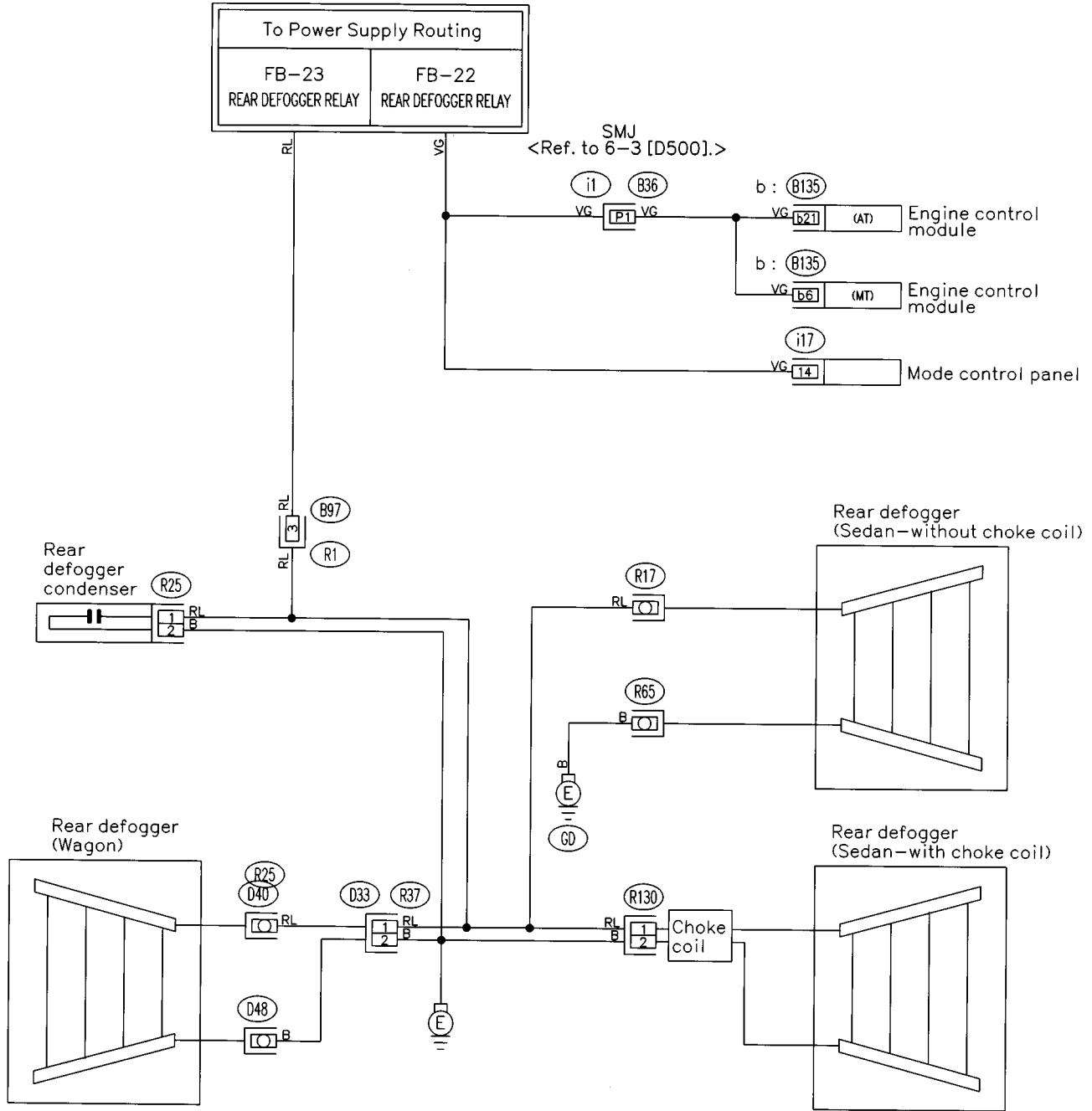

BU52-20

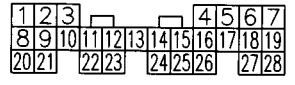

BU52-20

AF: REMOTE CONTROLLED REARVIEW MIRROR SYSTEM

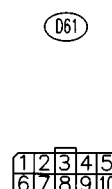
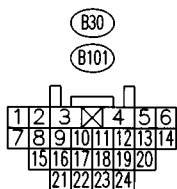
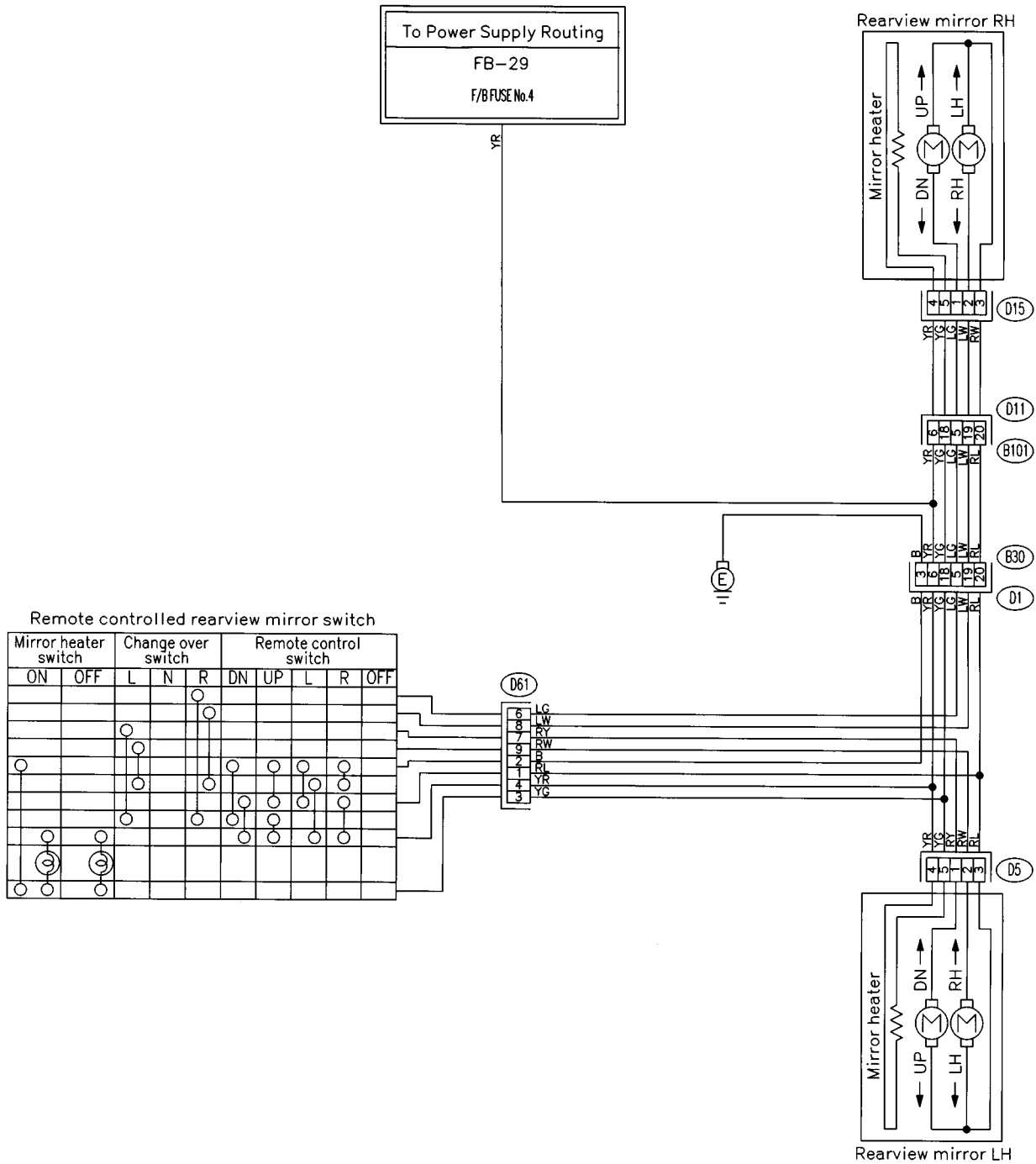

BU79-20

BU79-20

AG: SEAT BELT WARNING SYSTEM

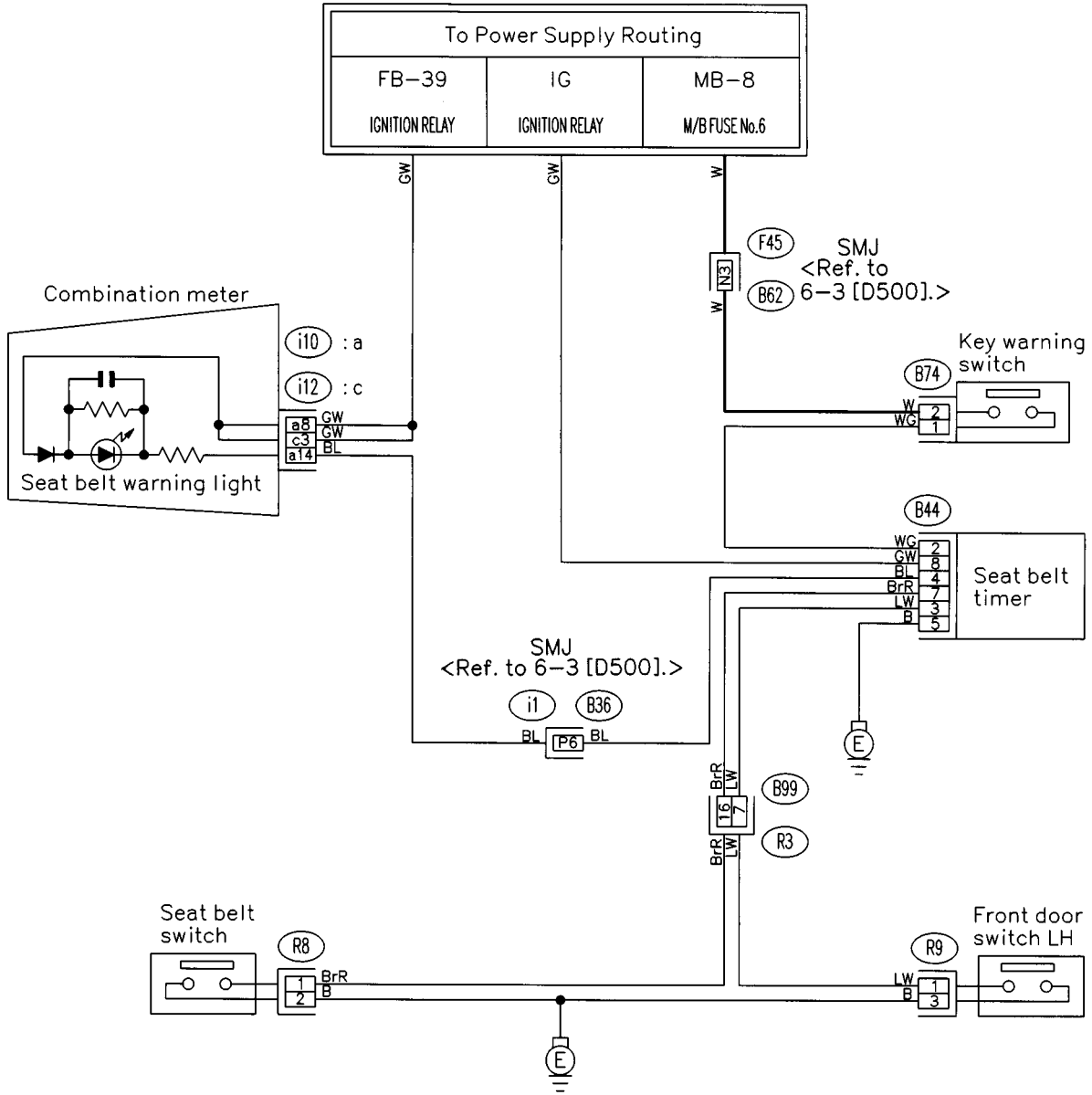

(R8) (B74) (Black) (R9) (B44) c: (i12) (Green)

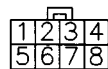

a: (i10) (Green)

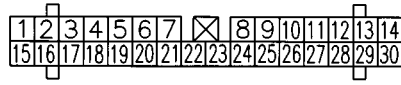
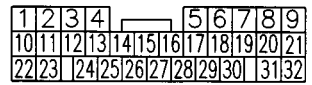

BU87-20

BU87-20

AH: SEAT HEATER SYSTEM

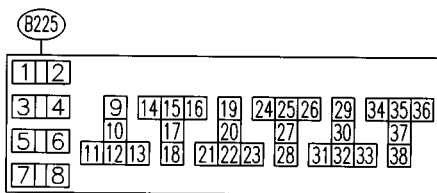
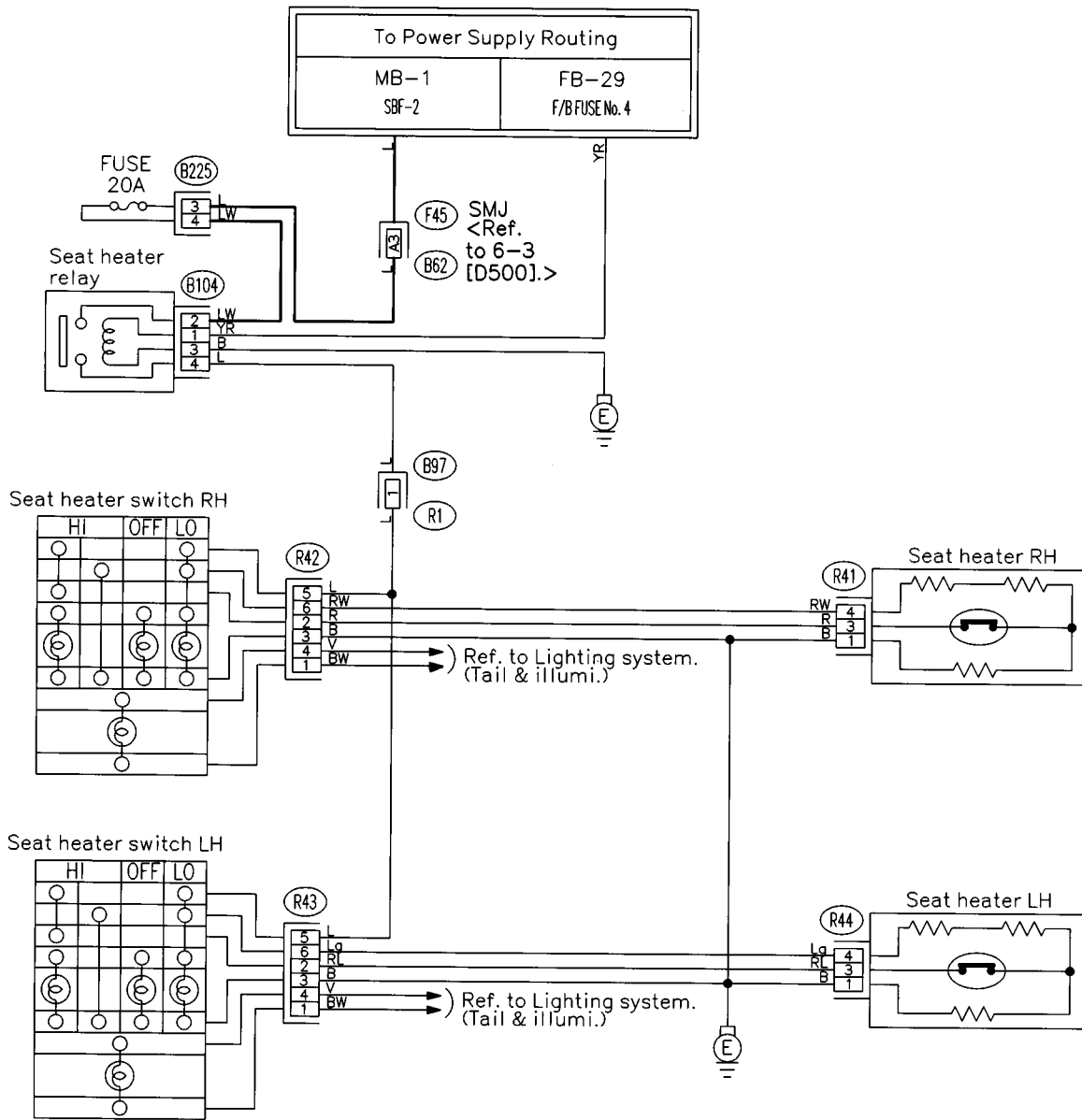

Relay block (Black)

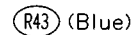
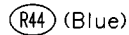
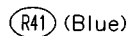

BU84-20



BU84-20

AI: STARTER SYSTEM

1. MT MODEL

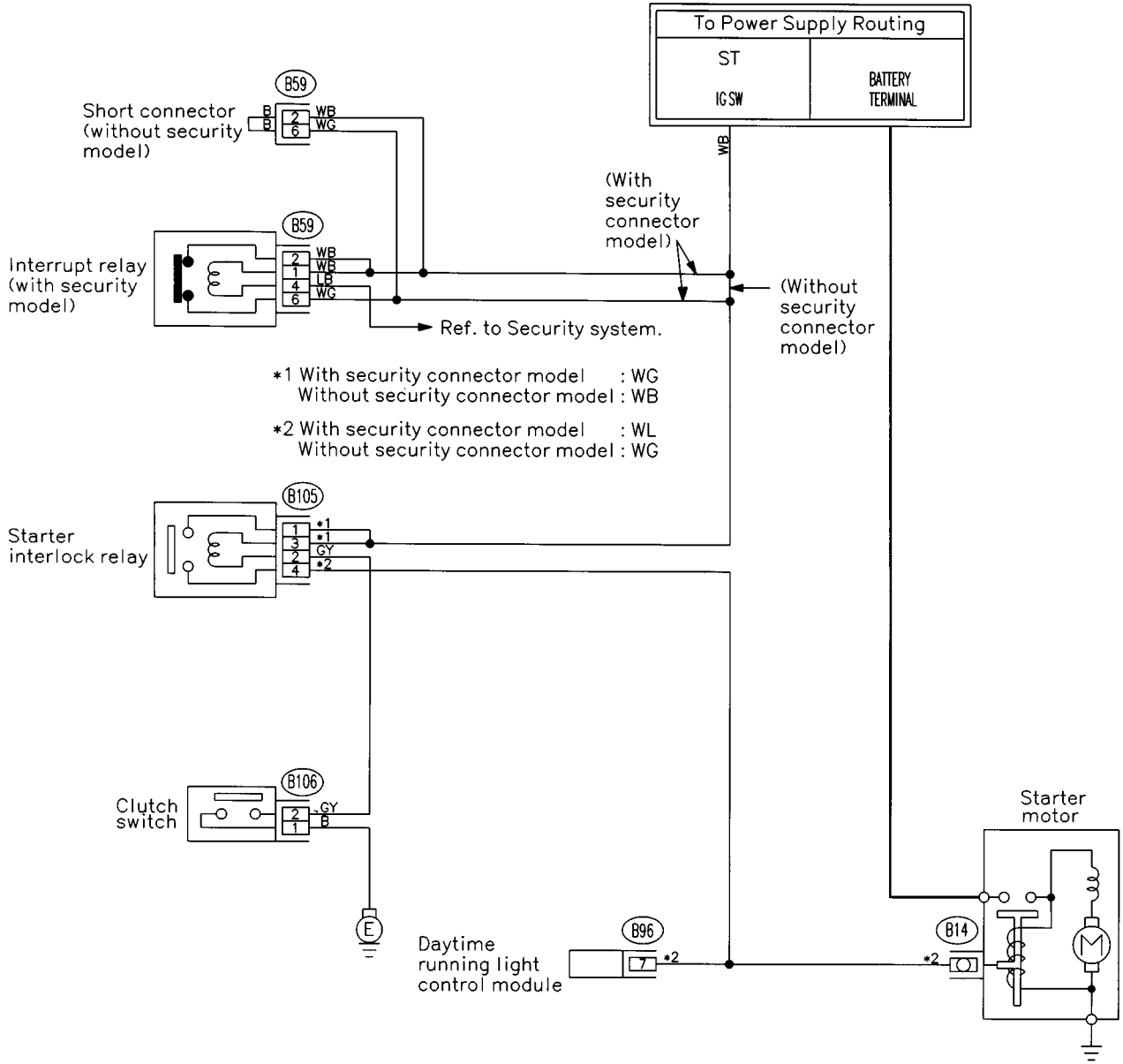

(B106)

(B105) (Blue)

(B59)

(B96) (Black)

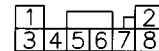

BU03-21

BU03-21

2. AT MODEL

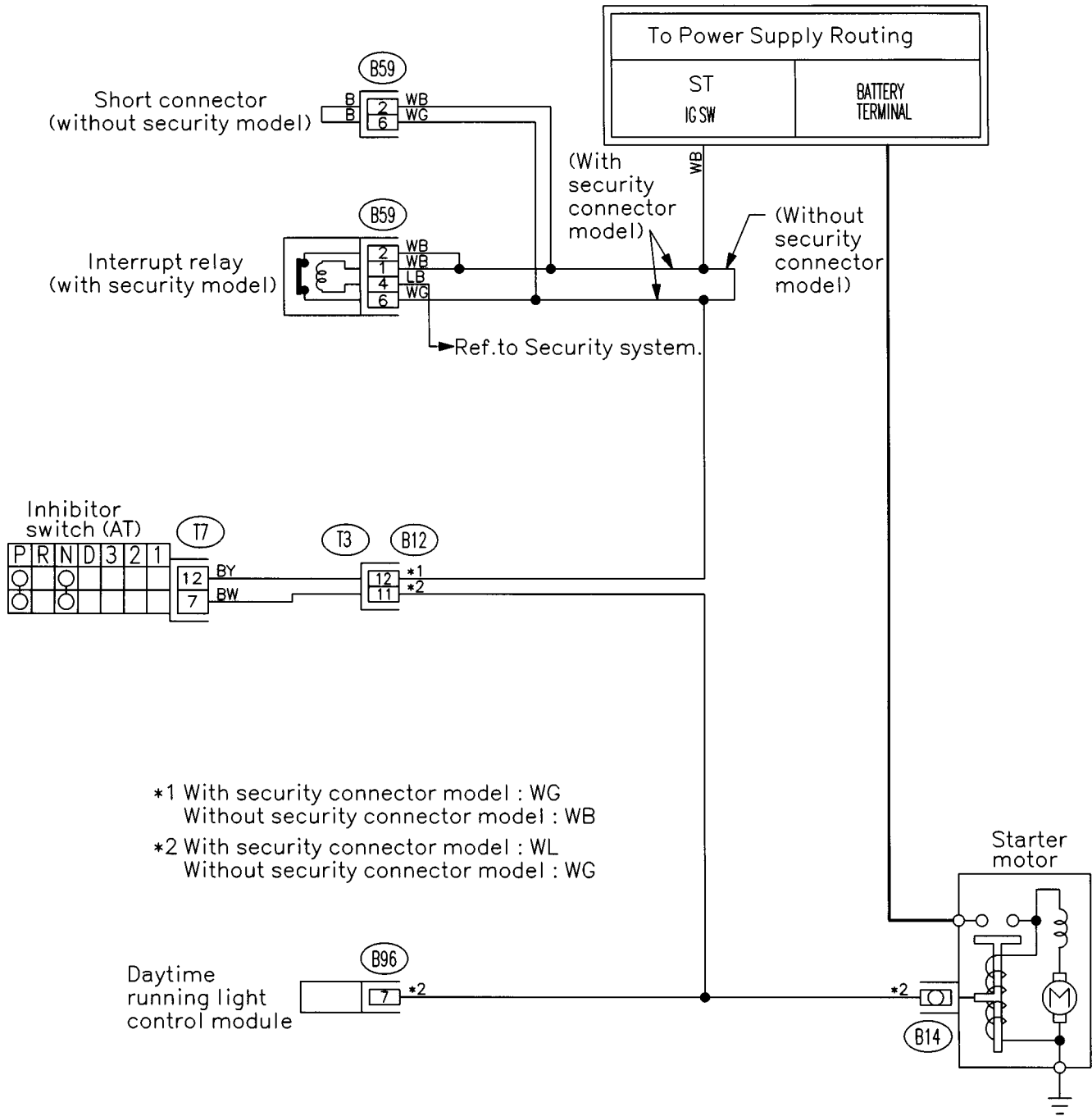

- *1 With security connector model : WG
Without security connector model : WB
- *2 With security connector model : WL
Without security connector model : WG

(B59)

(B96) (Black)

(T7)

(B12) (Black)

BU03-20

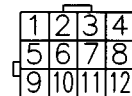
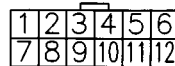
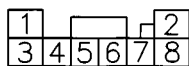

BU03-20

AJ: SUNROOF SYSTEM

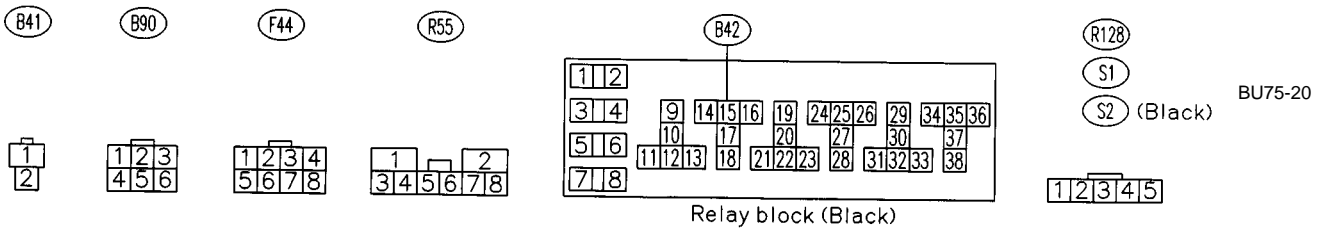
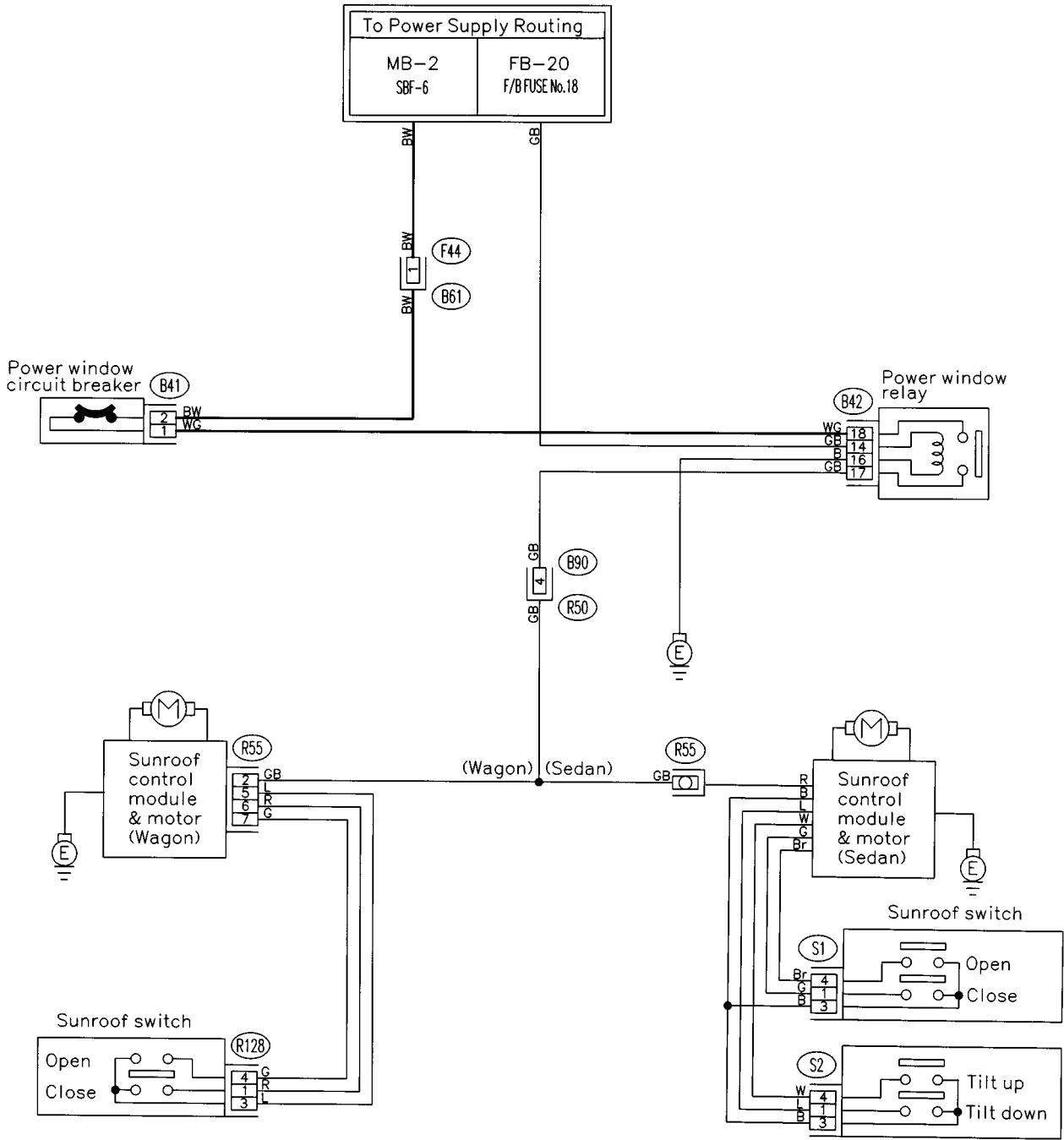

BU75-20

AK: TRAILER WIRE HARNESS (OPTION)

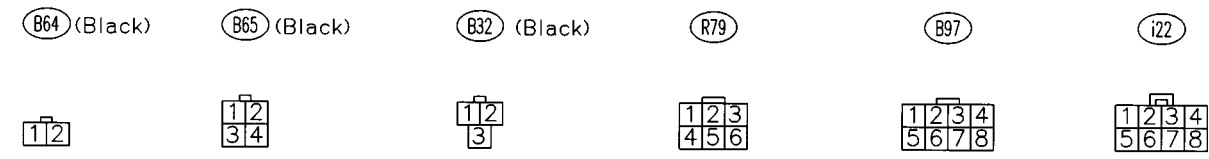
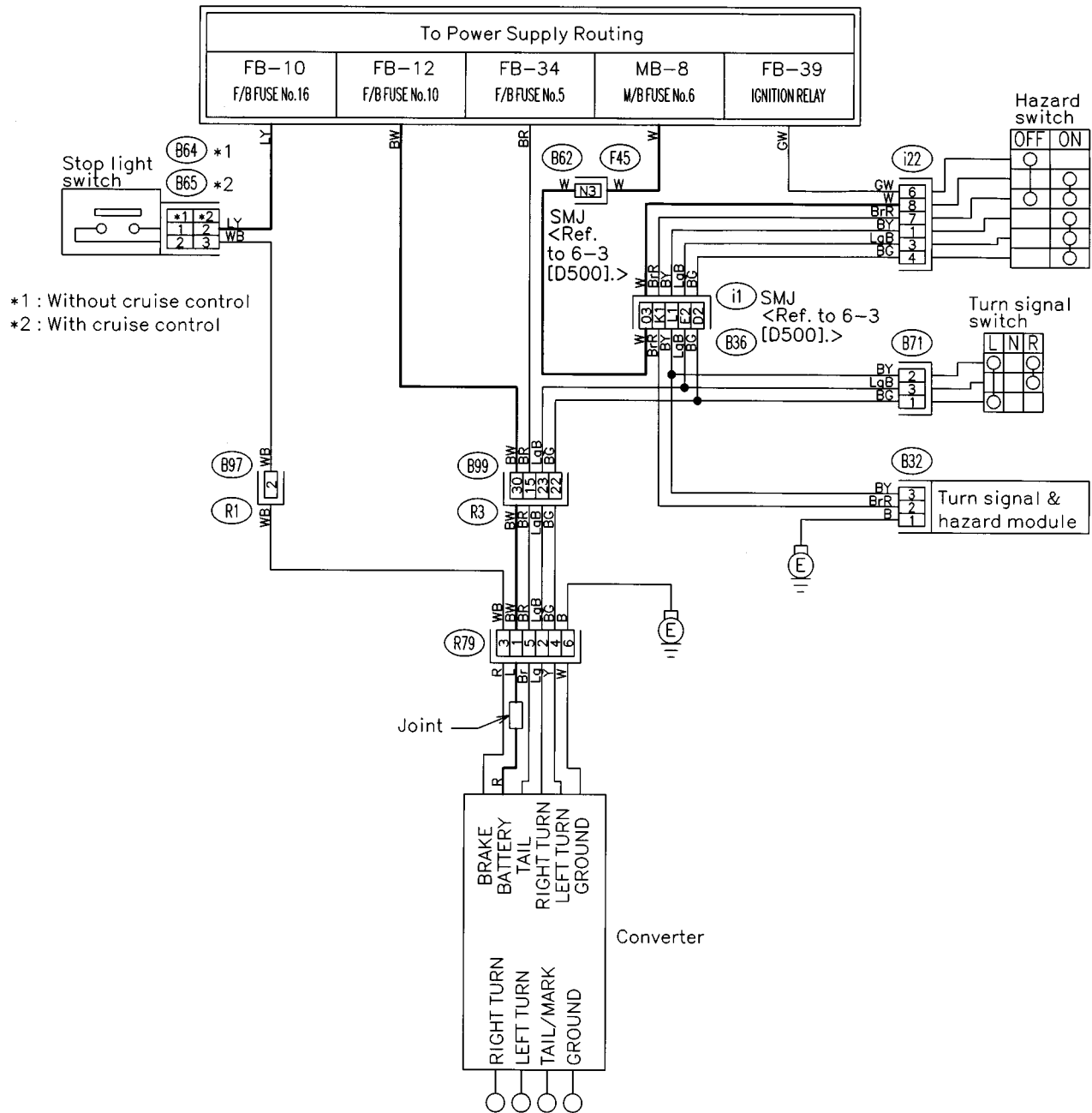

BU93-20

BU93-20

AL: WIPER AND WASHER SYSTEM (FRONT)

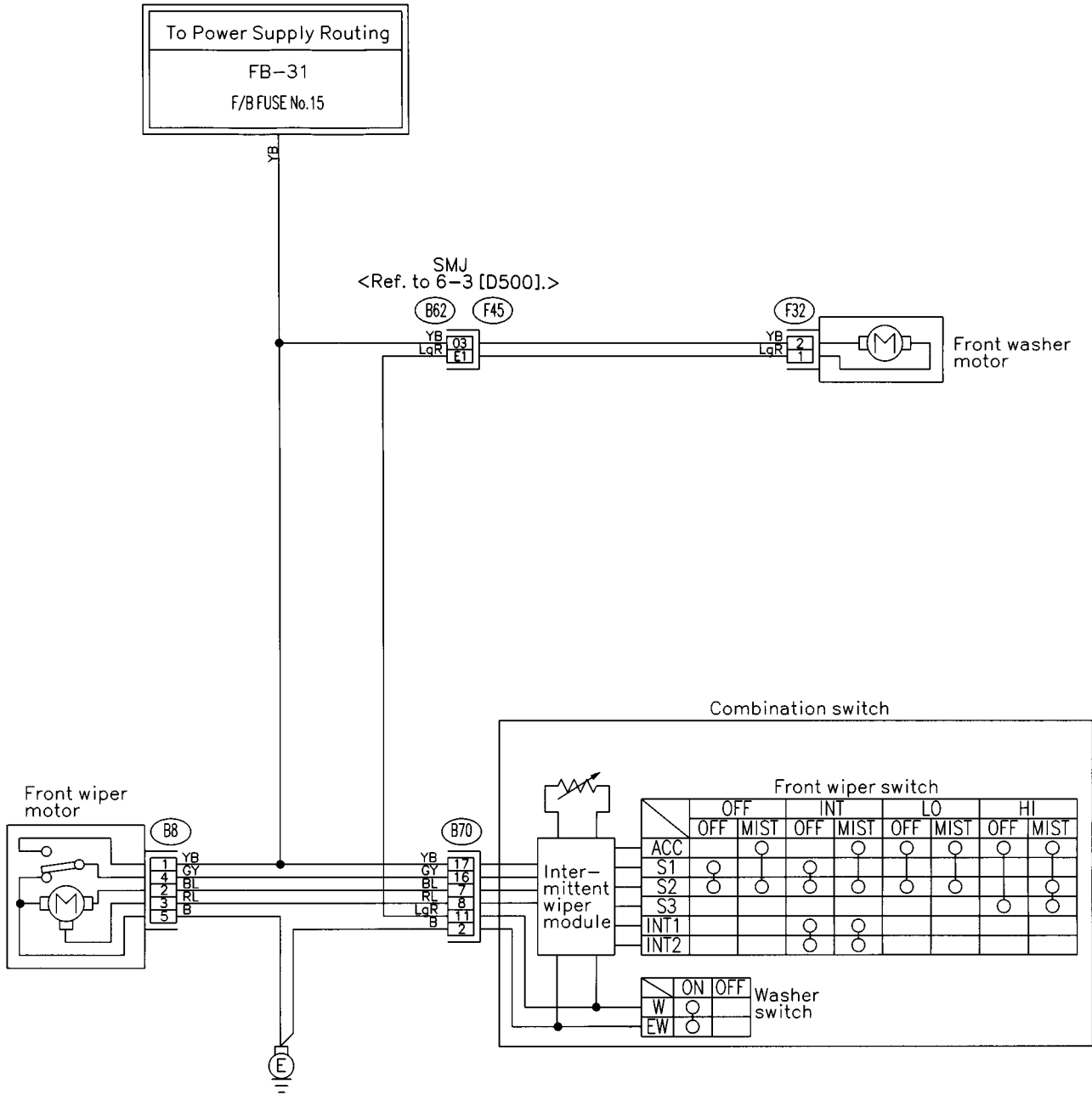

F32 (Green)

B8

B70

BU50-20

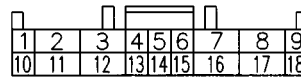

BU50-20

AM: WIPER AND WASHER SYSTEM (REAR)

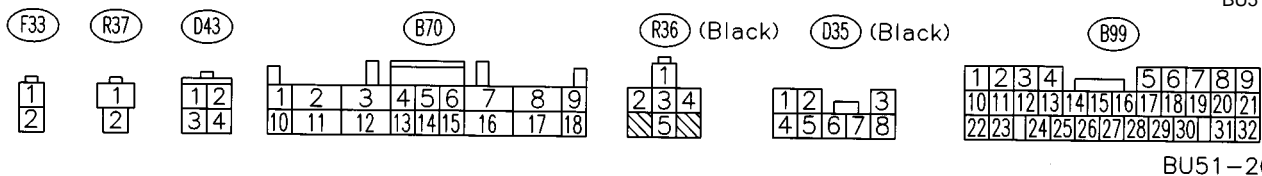
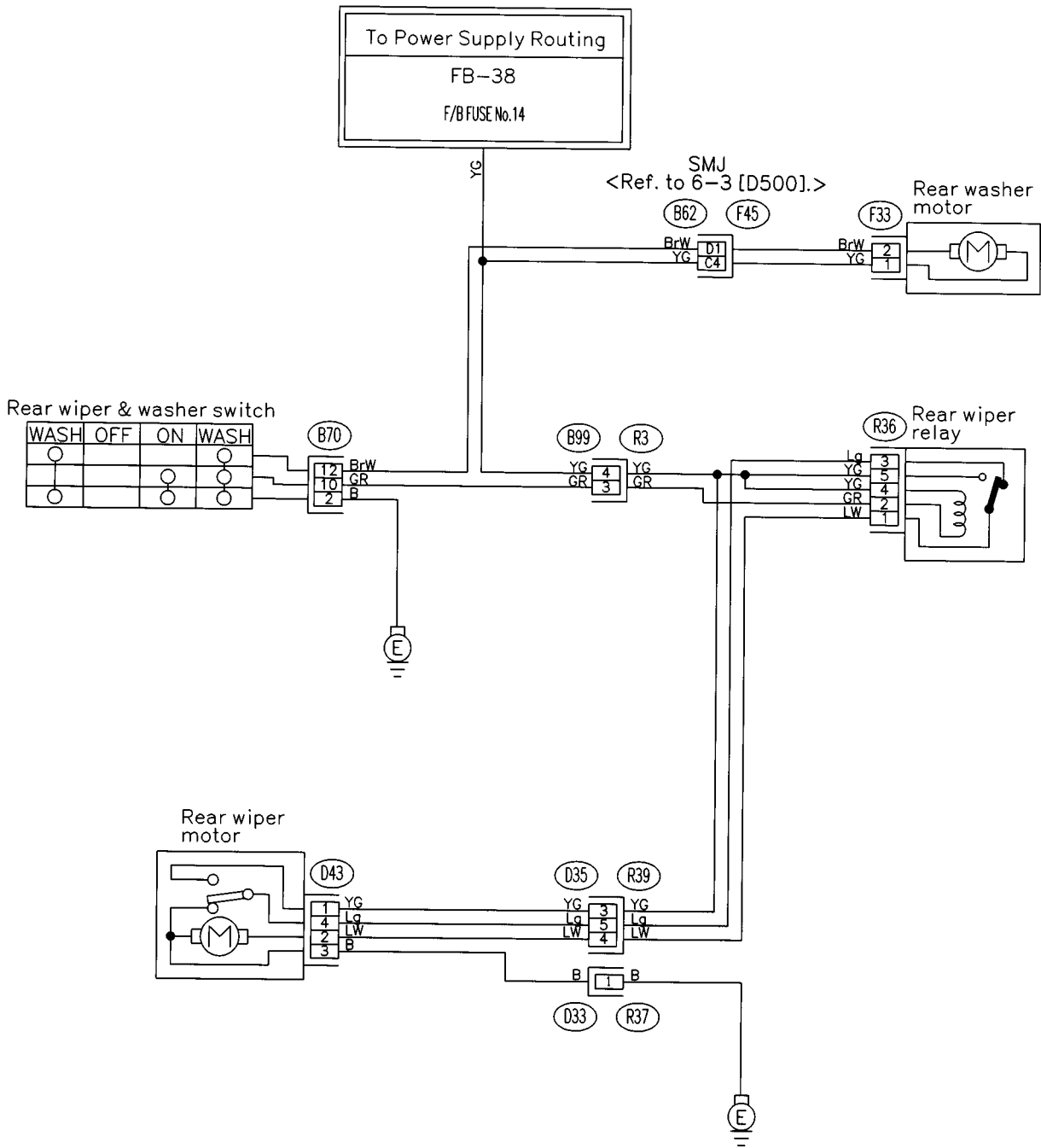

AN: WIPER DEICER SYSTEM

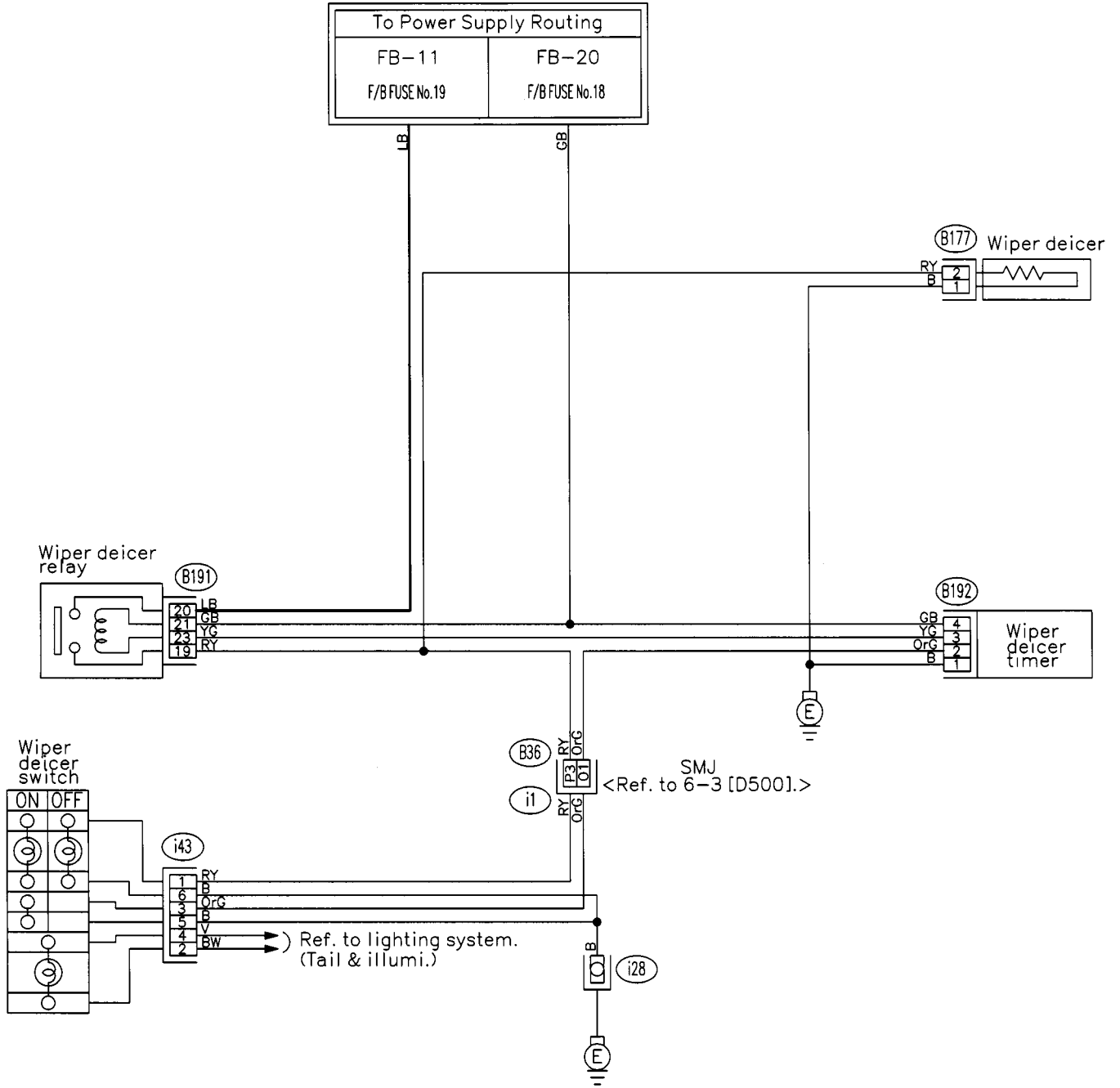

(B177)

(i43)

(B192)

(B191)

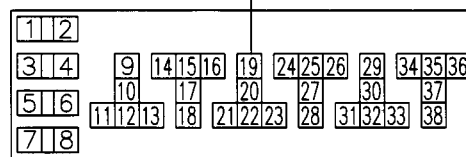
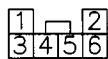

BL78-20

BL78-20

MEMO: